

John Deere
Service Manual
200, 210, 212, and 214
Lawn and Garden Tractors
SM-2105-(Oct-76)

John Deere Horicon Works
SM2105 (Oct-76)

LITHO IN U.S.A.
ENGLISH

JOHN DEERE 200, 210, 212 AND 214 LAWN AND GARDEN TRACTORS

Service Manual
SM-2105 (Oct-76)

TABLE OF CONTENTS

SECTION 10 - GENERAL

- Group 5 - Tractor Identification
- Group 10 - Specifications
- Group 15 - Fuel and Lubricants
- Group 20 - Tune-Up and Adjustments

SECTION 20 - ENGINE

- Group 5 - General Information
- Group 10 - Cylinder Head, Valves and Breather
- Group 15 - Minor Engine Recondition
- Group 20 - Major Engine Recondition
- Group 25 - Specifications and Special Tools

SECTION 30 - FUEL SYSTEM

- Group 5 - General Information
- Group 10 - Carburetor
- Group 15 - Air Cleaner
- Group 20 - Fuel Strainer and Fuel Tank
- Group 25 - Fuel Pump
- Group 30 - Specifications

SECTION 40 - ELECTRICAL SYSTEM

- Group 5 - General Information
- Group 10 - Cranking System
- Group 15 - Ignition System
- Group 20 - Charging System
- Group 25 - Lights
- Group 30 - Electric Lift

SECTION 50 - POWER TRAIN

- Group 5 - General Information
- Group 10 - Clutch and Variable Speed Drive
- Group 15 - Brakes
- Group 20 - 4-Speed Transaxle
- Group 25 - PTO Clutch

SECTION 60 - HYDRAULIC LIFT SYSTEM

- Group 5 - General Information
- Group 10 - Control Valve
- Group 15 - Pump
- Group 20 - Cylinder
- Group 20 - Attachments

SECTION 70 - MISCELLANEOUS

- Group 5 - Steering Linkage
- Group 10 - Front Wheels and Axles
- Group 15 - Manual Lift Linkage

SECTION 80 - SPECIAL SERVICE TOOLS

- Group 5 - Engine Convenience Service Tools
- Group 10 - Tractor Essential Service Tools
- Group 15 - Tractor Convenience Service Tools

(All information, illustrations, and specifications contained in this service manual are based on the latest information available at the time of publication. The right is reserved to make changes at any time without notice.)

Copyright © 1975
DEERE & COMPANY
Moline, Illinois
All rights reserved

INTRODUCTION

This service manual contains service and maintenance information for the John Deere 200, 210, 212 and 214 Lawn and Garden Tractors.

The manual is divided into sections. Each section pertains to a certain component or operational system of the tractor. The information is divided into groups within each section.

Emphasis is placed on diagnosing malfunctions, analysis and testing. Diagnosing malfunctions includes possible troubles, their causes and how to correct them. Under specific components these troubles are analyzed to help you understand what is causing the problem. In this way, you can eliminate the cause rather than just replace parts and have the same problem keep recurring.

Metric equivalents have been included, where applicable, throughout this service manual.

Specifications and special tools are found in the last group of each section.

This manual can be kept in its own cover or it can be filed in your service manual rack or in your Consumer Products Service Information Binder.

Whenever new or revised pages are provided, insert them into your manual as soon as you receive them. Your service manual will always be up-to-date and be a valuable asset in your service department.



This safety alert symbol identifies important safety messages in this manual. When you see this symbol, be alert to the possibility of personal injury and carefully read the message that follows.

Section 10 GENERAL

Group 5 TRACTOR IDENTIFICATION

CONTENTS

	Page		Page
GROUP 5 - TRACTOR IDENTIFICATION		GROUP 20 - TUNE-UP AND ADJUSTMENTS	
Serial Numbers	5-2	Purpose of Tune-Up and Adjustments	20-1
Tractor	5-2	Visual Inspection	20-1
Engine	5-2	Engine Tune-Up	20-1
Transaxle	5-2	Tractor Adjustments	20-1
Identification Codes	5-2	Tune-Up Guide	20-1
Tire Codes	5-2	Tune-Up and Adjustments	20-2
		Clean Engine Shrouds and	
GROUP 10 - SPECIFICATIONS		Cooling Fins	20-2
Engine Specifications	10-1	Clean or Replace Air Filter	
Battery Specifications	10-1	Element	20-2
Tractor Specifications	10-2	Clean Fuel Strainer	20-2
Tire Specifications	10-3	Check and Clean Engine Crankcase	
Rear Wheel Weight Bolt Size Chart	10-3	Breather	20-2
Bolt Torque Chart	10-4	Check Spark Plug Gap	20-3
Set Screw Seating Torque Chart	10-4	Check Ignition Breaker Points and	
		Engine Timing	20-3
GROUP 15 - FUEL AND LUBRICANTS		Adjust Carburetor	20-5
Fuel	15-1	Check Engine Speed	20-5
Lubricants	15-1	Change Engine Crankcase Oil	20-6
Engine Crankcase	15-1	Check or Change Transaxle Lubricant	20-6
Transaxle	15-1	Lubricate Grease Fittings	20-6
Tractor Grease Fittings	15-1	Repack PTO Clutch Bearing	20-6
Hydraulic System (Optional Equip.)	15-1	Service Battery	20-6
Capacities	15-1	Check Tire Pressure	20-6
Service Intervals	15-2	Check Operation and Condition of:	
Lubricating Grease Fittings	15-2	Lights	20-6
Changing Engine Crankcase Oil	15-3	Lift System	20-6
Changing Transaxle Lubricant	15-3	Steering	20-6
Repacking PTO Clutch Bearing	15-4	Brakes	20-6
Lubricating Integral Hitch Grease		Belts and Equipment	20-6
Fitting	15-4		
Checking Hydraulic Lift System Fluid			
Level	15-4		

SERIAL NUMBERS

Tractor



Fig. 1-Tractor Serial Number

The tractor serial number, Fig. 1, is located on the pedestal below the steering wheel.

The first letter indicates the "family of machine"; the next three numbers or letters, the "model or machine designation"; the letter in the fifth position indicates the "model year". This is followed by a space (for computer purposes), and a six-digit serial number and the letter "M" denoting Horicon as the factory of manufacture.

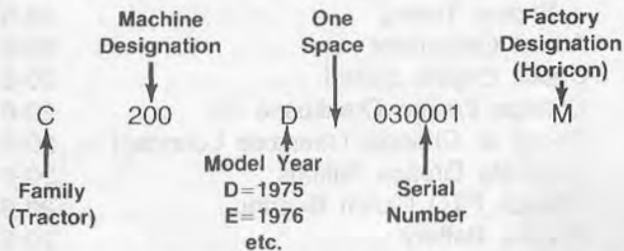

When ordering parts, use only the six-digit serial number. When writing about or filling out warranty claims, use all thirteen numbers, letters and spaces shown on the machine serial number plate.

Engine



Fig. 2-Engine Serial Number

The engine serial number, Fig. 2, is located on the engine shroud.

Transaxle

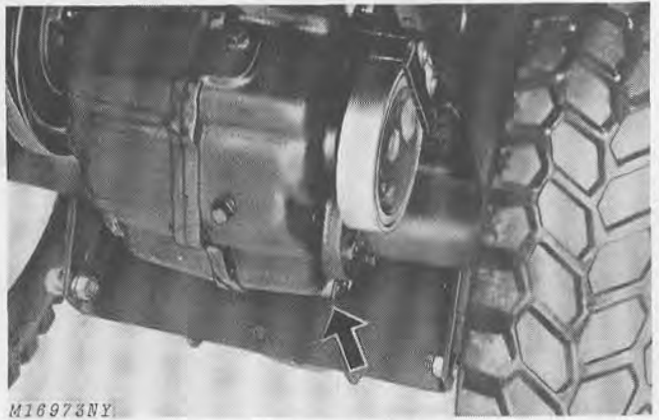

Fig. 3-Transaxle Serial Number

The transaxle serial number, Fig. 3, is located on the transaxle case next to the L.H. axle housing.

IDENTIFICATION CODES

Tire Codes

John Deere 200, 210, 212 and 214 Tractors are available with four different combinations of tires as follows:

Tire Code	Size Front	Size Rear	Tread
GT-3	16x6.50-8	23x8.50-12	High-Flotation
GT-4	4.80/4.00-8 -----	----- 23x8.50-12	Studded Traction
GT-5	16x6.50-8	23x10.50-12	High-Flotation
GT-8 Bar Tread	16x6.50-8 or 4.80/4.00-8 -----	----- 23x10.50-12	High-Flotation Traction

NOTE: The 200 Tractor is equipped with GT-3 tires as standard equipment. The 210, 212 and 214 Tractors are equipped with GT-5 tires as standard equipment.

Group 10 SPECIFICATIONS

ENGINE SPECIFICATIONS

Item	200	210	212	214
Engine Model No.	K181QS	K241AQS	K301AQS	K321AQS
Manufacturer	Kohler	Kohler	Kohler	Kohler
Cylinders	One	One	One	One
Stroke/Cycle	Four	Four	Four	Four
Bore	2.94 in. (7.46 cm)	3.25 in. (8.25 cm)	3.38 in. (8.58 cm)	3.50 in. (8.89 cm)
Stroke	2.75 in. (6.98 cm)	2.88 in. (7.31 cm)	3.25 in. (8.25 cm)	3.25 in. (8.25 cm)
Displacement	18.6 cu. in.	23.9 cu. in.	29.1 cu. in.	31.3 cu. in.
Speeds (Fast) No Load	3400 to 3500 rpm	3400 to 3500 rpm	3400 to 3500 rpm	3400 to 3500 rpm
Speeds (Idle)	1700 to 1900 rpm	1700 to 1900 rpm	1700 to 1900 rpm	1700 to 1900 rpm
Horsepower*	8	10	12	14
Normal Compression	110 to 120 psi	110 to 120 psi	110 to 120 psi	110 to 120 psi
Valve Clearance				
Intake (Cold)	0.007 in. (0.178 mm)	0.010 in. (0.254 mm)	0.010 in. (0.254 mm)	0.010 in. (0.254 mm)
Exhaust (Cold)	0.016 in. (0.406 mm)	0.020 in. (0.508 mm)	0.020 in. (0.508 mm)	0.020 in. (0.508 mm)
Ignition	Battery	Battery	Battery	Battery
Spark Plug	Champion-J-8 or XJ8 AC-45-M or R-46 Prestolite-14-7 or 14-R8	Champion-H-10 AC-45L Prestolite-14-L7B	Champion-H-10 AC-45L Prestolite-14-L7B	Champion-H-10 AC-45L Prestolite-14-L7B
Spark Plug Gap	0.025 in. (0.635 mm)	0.035 in. (0.889 mm)	0.035 in. (0.889 mm)	0.035 in. (0.889 mm)
Breaker Point Gap	0.020 in. (0.508 mm)	0.020 in. (0.508 mm)	0.020 in. (0.508 mm)	0.020 in. (0.508 mm)
Charging System	Alternator	Alternator	Alternator	Alternator
Starter	12-Volt	12-Volt	12-Volt	12-Volt
Air Filter	Dry-type	Dry-type	Dry-type	Dry-type

*The horsepower rating shown is established by the engine manufacturer in accordance with Standard Internal Combustion Engine Institute procedure. It is corrected at 60°F. and 29.22 in. Hg. Barometer and is developed from laboratory test engines equipped with standard air cleaner and muffler.

BATTERY SPECIFICATIONS

Tractor	Battery
200	John Deere, 12 Volt, (AM30094), BCI Group U1, 135 cold cranking amps at 0°F. (-17°C), 30-minute reserve capacity.
210, 212, 214	John Deere, 12 Volt, (AM31186), BCI Group 22F, 255 cold cranking amps at 0°F. (-17°C), 55-minute reserve capacity.

TRACTOR SPECIFICATIONS

Item	200	210, 212, 214
CAPACITIES		
Fuel Tank	3-1/2 U.S. Gallons (13.25 l)	3-1/2 U.S. Gallons (13.25 l)
Crankcase	2-1/2 U.S. Pints (1.18 l)	3 U.S. Pints (1.42 l)
Transaxle.....	3-1/2 U.S. Pints (1.65 l)	3-1/2 U.S. Pints (1.65 l)
Hydraulic System (Optional)	2 U.S. Pints (0.94 l)
TRANSMISSION		
Type	Transaxle	Transaxle
Gear Selections.....	4 forward - 1 reverse	4 forward - 1 reverse
TRAVEL SPEEDS -@3400 rpm		
1st Gear (Variable).....	0.3 to 0.9 mph (.6 to 1.6 kms/hr)	0.3 to 0.9 mph (.6 to 1.6 kms/hr)
2nd Gear (Variable).....	1.0 to 2.7 mph (2.1 to 4.6 kms/hr)	1.0 to 2.7 mph (2.1 to 4.6 kms/hr)
3rd Gear (Variable)	1.8 to 4.7 mph (3.8 to 8.0 kms/hr)	1.8 to 4.7 mph (3.8 to 8.0 kms/hr)
4th Gear (Variable)	2.6 to 7.0 mph (5.5 to 11.9 kms/hr)	2.6 to 7.0 mph (5.5 to 11.9 kms/hr)
Reverse (Variable)	1.4 to 3.7 mph (2.4 to 5.3 kms/hr)	1.4 to 3.7 mph (2.4 to 5.3 kms/hr)
DIMENSIONS		
Wheelbase	46 in. (1.168 m)	46 in. (1.168 m)
Overall Length	67-1/2 in. (1.715 m)	67-1/2 in. (1.715 m)
Overall Height	42 in. (1.067 m)	42 in. (1.067 m)
Overall Width (maximum) ..	41-1/2 in. (1.054 m)	41-1/2 in. (1.054 m)
WHEEL TREAD		
Front.....	31 in. (78.74 cm)	31 in. (78.74 cm)
Rear (GT-3 Tires).....	27 in. or 33 in. (68.58 cm or 83.82 cm)	27 in. or 33 in. (68.58 cm or 83.82 cm)
(GT-5 Tires)	28-1/2 in. or 31 in. (72.39 cm or 78.74 cm)	28-1/2 in. or 31 in. (72.39 cm or 78.74 cm)
BRAKES		
Type	Band, pedal-operated	Band, pedal-operated
Parking.....	Hand-lock foot brake	Hand-lock foot brake
CLUTCH		
	V-belt system	V-belt system
PTO CLUTCH		
	Manual	Manual
STEERING		
	Enclosed gear	Enclosed gear
LIFT*		
	Manual, Electric	Manual, Electric, Hydraulic
SHIPPING WEIGHT		
	691 lbs. (313 kg)	759 lbs. (344 kg)

*Electric and Hydraulic Lifts are dealer installed options.

TIRE SPECIFICATIONS

Tire Code	Location	Size	Tubeless	Ply-Rating	Tread	Tire Inflation Pressure
GT-3	Front	16x6.50-8	Yes*	2	High-Flotation	6 to 16 psi (41 to 110 kPa)
	Rear	23x8.50-12	Yes*	2		5 to 10 psi (34 to 69 kPa)
GT-4	Front	4.80/4.00-8	No	4	Studded Traction	12 to 40 psi (82 to 276 kPa)
	Rear	23x8.50-12	Yes*	2		5 to 10 psi (34 to 69 kPa)
GT-5	Front	16x6.50-8	Yes*	2	High-Flotation	6 to 16 psi (41 to 110 kPa)
	Rear	23x10.50-12	Yes*	2		5 to 10 psi (34 to 69 kPa)
GT-8 Bar Tread	Front**	16x6.50-8	Yes*	2	High-Flotation Traction	6 to 16 psi (41 to 110 kPa)
	Rear	23x10.5-12	Yes*	2		5 to 10 psi (34 to 69 kPa)

*Tubes Available for service. See your parts catalog.

**Use 4.80/4.00-8 front tires with front-end loaders.

REAR WHEEL WEIGHT BOLT SIZE CHART

Tire/Wheel Option	Wheel Position	No. of Weights	Bolt Size
GT-3 or GT-4	Narrow	1	1/2 x 5-1/2
GT-3 or GT-4	Narrow	2	1/2x7-1/2
GT-3 or GT-4	Wide	1	1/2x5-1/2
GT-3 or GT-4	Wide	2	1/2x7-1/2
GT-5	Narrow	1	1/2x5-1/2
GT-5	Narrow	2	1/2x8
GT-5	Wide	1	1/2x5-1/2
GT-5 or GT-8	Wide	2	1/2x7-1/2

BOLT TORQUE CHART

Grade of Bolt		SAE-2	SAE-5	SAE-8	Socket or Wrench Size	
Min. Tensile Strength		64,000 PSI	105,000 PSI	150,000 PSI		
Grade Marking on Bolt						
U.S. Standard		TORQUE IN FOOT POUNDS			U.S. Regular	
Bolt Dia.	U.S. Dec. Equiv.				Bolt Head	Nut
1/4	.250	6	10	14	7/16	7/16
5/16	.3125	13	20	30	1/2	1/2
3/8	.375	23	35	50	9/16	9/16
7/16	.4375	35	55	80	5/8	11/16
1/2	.500	55	85	120	3/4	3/4
9/16	.5625	75	130	175	13/16	7/8
5/8	.625	105	170	240	15/16	15/16
3/4	.750	185	300	425	1-1/8	1-1/8
7/8	.875	*160	445	685	1-5/16	1-5/16
1	1.000	250	670	1030	1-1/2	1-1/2

Multiply Readings by 12 for inch pound values.

*"B" Grade bolts larger than 3/4-inch are sometimes formed hot rather than cold which accounts for the lower recommended torque.

NOTE: Allow a tolerance of plus or minus 10% on all torques given in this chart.

SET SCREW SEATING TORQUE CHART

Screw Size	Torque in Inch Pounds	
	Cup Point	Square Head
#5	9	—
#6	9	—
#8	20	—
#10	33	—
1/4	87	212
5/16	165	420
3/8	290	830
7/16	430	—
1/2	620	2100
9/16	620	—
5/8	1225	4250
3/4	2125	7700

Divide Readings by 12 for foot pound values

NOTE: Allow a tolerance of plus or minus 10% on all torques given in this chart.

Group 15 FUEL AND LUBRICANTS

FUEL

Always use fresh, clean "regular grade or non-leaded" gasoline having an octane rating of 85 or higher. We recommend non-leaded gasoline because it reduces cylinder head deposits.

Do not use premium, ethyl or white gasoline. Never use special additives such as carburetor cleaners, de-icers, or moisture-removing liquids in your gasoline.

IMPORTANT: Do not mix oil with gasoline.

IMPORTANT: Do not permit dirt or other foreign matter to enter the fuel system. This could cause hard starting, poor performance and engine damage. Always use clean gasoline storage cans and funnels.

LUBRICANTS

Engine Crankcase

John Deere Torq-Gard Supreme engine oil is recommended because of its superior lubricating qualities. If a different brand of oil is used, it must conform to one of the following specifications.

SPI Service CD/SE, CD/SD, CC/SD or SD MIL-L-46152 or MIL-L-2104C*.

**As further assurance of quality, the oil should be identified as suitable for API Service Designation SD.*

IMPORTANT: Never put additives in the crankcase oil.

Depending on the expected prevailing temperature for the fill period, use oil of viscosity shown in the following chart.

Air Temperature	John Deere Torq-Gard Supreme Oil	Other Oils	
		Single Viscosity Oil	Multi-Viscosity Oil
Above 32°F	SAE 30	SAE 30	Not recommended
-10° to 32°F -23.3°C to 0°C	SAE 10W-20	SAE 10W	SAE 10W-30
Below -10°F -23.3°C	SAE 5W-20*	SAE 5W*	SAE 5W-20*

**Some increase in oil consumption may be expected when SAE 5W-20 or SAE 5W oils are used. Check oil level more frequently.*

Transaxle

John Deere AM30200 Transmission Lubricant or SAE 90 Gear Lubricant. Also an equivalent SCL Multipurpose-Type Gear Oil.

Tractor Grease Fittings

John Deere Multipurpose Lubricant SAE (Seasonal Grade) or equivalent Multipurpose-Type Grease.

Hydraulic System (Optional Equipment)

John Deere All-Weather Hydrostatic Fluid or an equivalent Type "F" Automotive Automatic Transmission Fluid.

CAPACITIES

Fuel Tank	3-1/2 U.S. gallons (13.25 l)
Crankcase:	2-1/2 U.S. pints (1.18 l)
200, 212, 214	3 U.S. pints (1.42 l)
Transaxle	3-1/2 U.S. pints (1.65 l)
Hydraulic System (optional equip.)	2 U.S. pints (0.94 l)

SERVICE INTERVALS

Lubricating Grease Fittings

Grease tractor grease fittings in Spring and Fall Season. Tractor grease fitting locations are as follows:

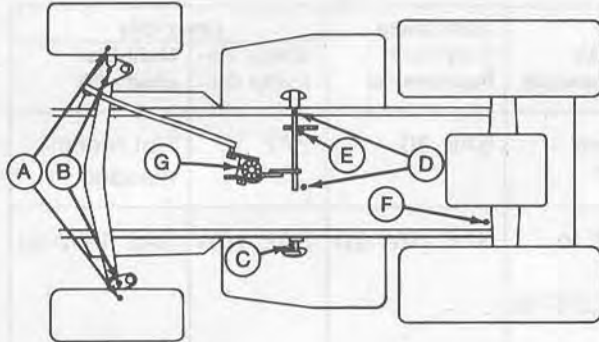

M14459N

- | | |
|-----------------------|----------------------|
| A—Front Wheel Hubs | E—Primary Lift Shaft |
| B—Front Axle Spindles | F—Rear Brake Shaft |
| C—Brake Pedal Shaft | G—Steering Gear* |
| D—Clutch Pedal Shaft | |

Fig. 1—Grease Fitting Locations (Serial No. 30,001-55,000)

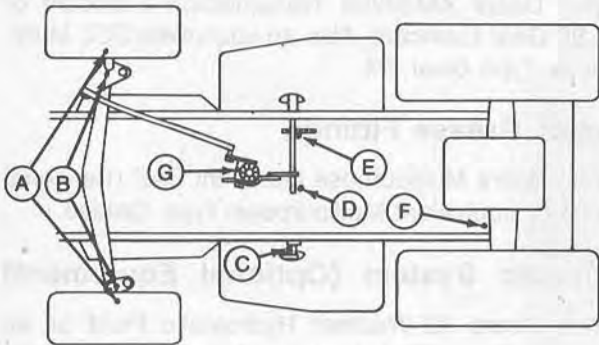

M14460N

- | | |
|-----------------------|----------------------|
| A—Front Wheel Hubs | E—Primary Lift Shaft |
| B—Front Axle Spindles | F—Rear Brake Shaft |
| C—Brake Pedal Shaft | G—Steering Gear* |
| D—Clutch Pedal Shaft | |

Fig. 2—Grease Fitting Locations (Serial No. 55,001-70,000)

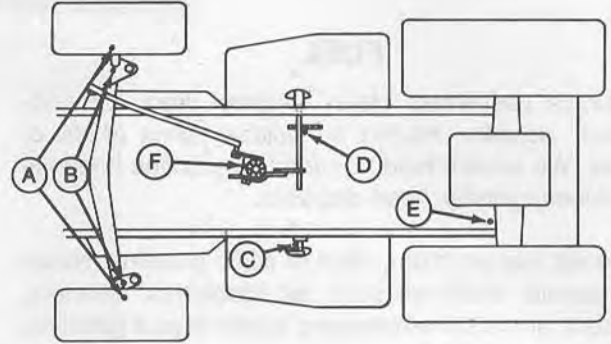

M14461N

- | | |
|-----------------------|----------------------|
| A—Front Wheel Hubs | D—Primary Lift Shaft |
| B—Front Axle Spindles | E—Rear Brake Shaft |
| C—Brake Pedal Shaft | F—Steering Gear* |

Fig. 3—Grease Fitting Locations (Serial No. 70,001-)

***IMPORTANT:** Do not overlubricate steering column fitting. Only 3 to 4 strokes with a hand grease gun are necessary. Do not use a high-pressure grease gun on this fitting.

Changing Engine Crankcase Oil

Change crankcase oil after the first 2 hours of operation and every 25 hours of operation thereafter.

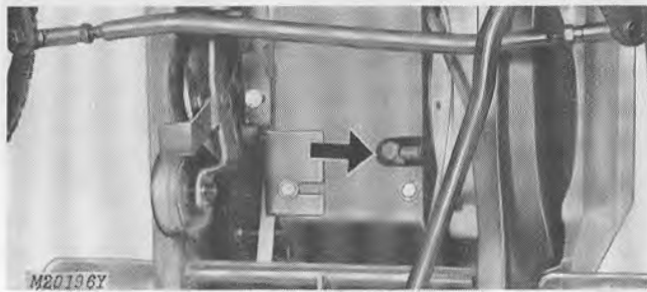

Fig. 4-Draining Crankcase Oil

NOTE: For convenience, a suitable length of 5/8-inch (15.88 mm) garden hose or plastic tubing may be installed on the drain valve to allow oil to drain.

Open oil drain valve Fig. 4 and allow oil to drain into a container.

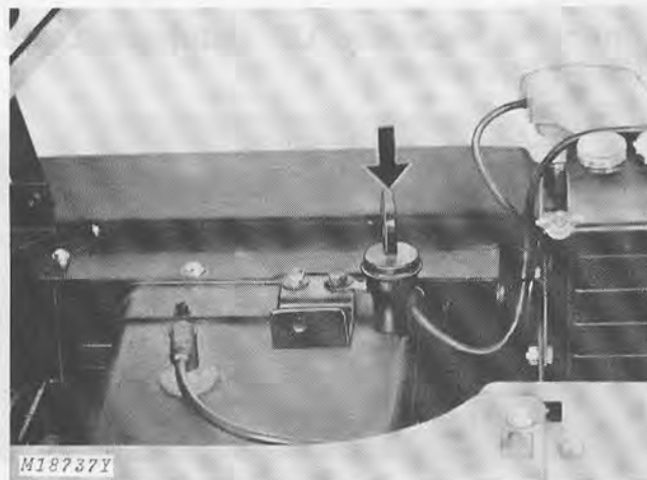
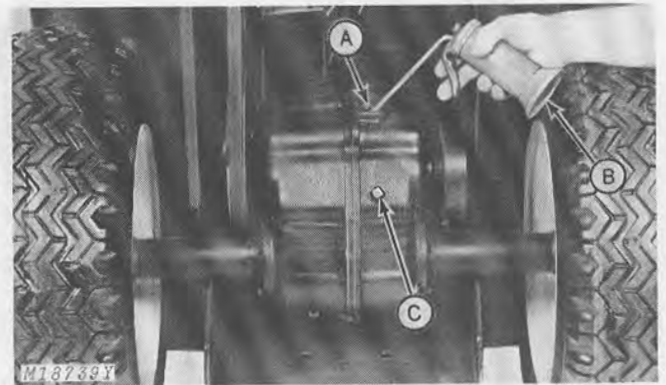

Fig. 5-Filling Crankcase

Close oil drain valve. Fill crankcase with oil of the proper viscosity to "F" mark on dipstick Fig. 5 (see page 10-15-1 for crankcase capacity).

Changing Transaxle Lubricant



A—Oil Level Filler Hole C—Drain Plug
B—Pressure Oil Can

Fig. 6-Changing Transaxle Lubricant

Change transaxle lubricant every 2 years or 500 hours of operation. Remove transaxle drain plug (C) and drain oil. Wipe plug clean and replace it in transaxle.

Remove plug from filler hole (A) and fill transaxle with 3-1/2 U.S. pints (1.65 l) of AM30200 Transmission Lubricant, SAE 90 Gear Lubricant or an equivalent SCL Multipurpose Gear Oil.

Repacking PTO Clutch Bearing

Repack PTO clutch bearing, each spring and fall.

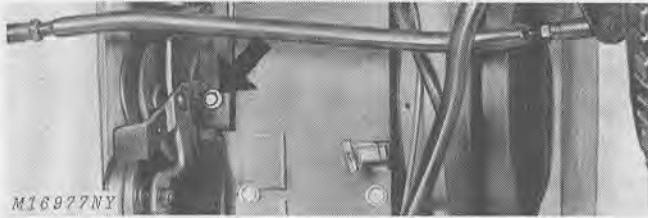

Fig. 7-PTO Clutch Brake Cap Screw

Using a 1/2-inch socket wrench with extension, loosen PTO clutch brake cap screw, Fig. 7, only enough to permit removal of PTO clutch assembly.

Pivot clutch arm clip upward and slide clutch arm to the rear to remove clutch arm from sheave hub.

Slide PTO assembly off the shaft. Check condition of clutch and brake linings. Replace linings as necessary. Use solvent to remove old grease from bearing.

Dry bearing thoroughly and repack it with John Deere High-Temperature grease (AT30408) or its equivalent.

Install PTO assembly on shaft and replace clutch arm. Lock in place with clip.

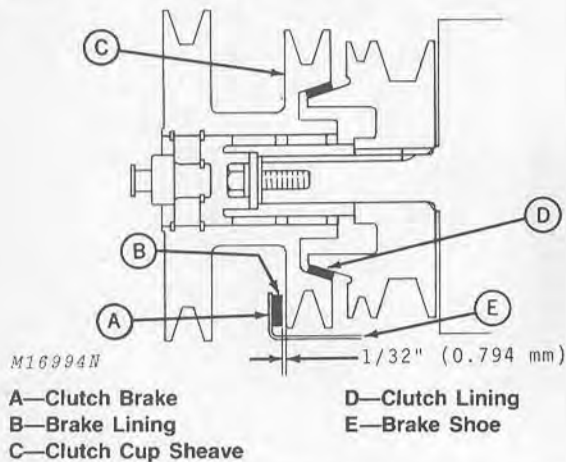

Fig. 8-Adjusting Clearance Between Brake and Sheave

Engage PTO clutch lever (up position). Check distance between the clutch brake (A) and clutch cup sheave (C) for 1/32-inch (0.794 mm) clearance, Fig. 8.

If adjustment is required, use a 1/2-inch socket with extension. Loosen clutch brake cap screw, Fig. 7. Slide brake shoe in slotted hole until proper adjustment is obtained. Tighten cap screw.

Lubricating Integral Hitch Grease Fitting (Extra Equipment)

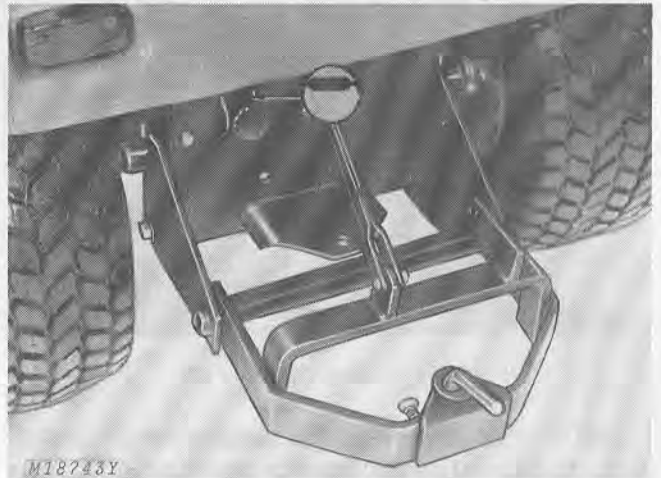

Figure 9-Integral Hitch (Extra Equipment)

If the tractor is equipped with an integral hitch (extra equipment) lubricate the rear lift pivot, Figure 9.

Checking Hydraulic Lift Lubricant Level (Extra Equipment)

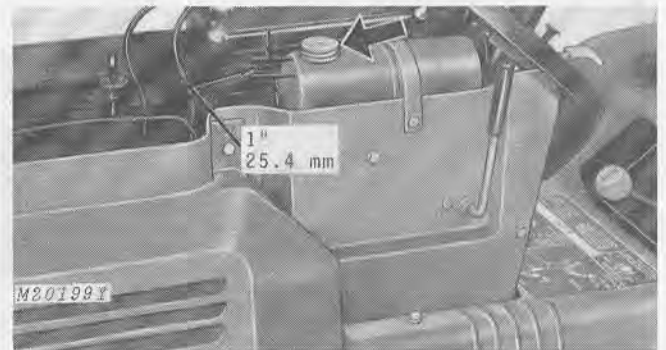

Figure 10

Once a week or every 50 hours of operation, check hydraulic fluid level. Park the tractor on a level surface, shut off engine, and set parking brake.

Remove reservoir cap (arrow). The hydraulic fluid level should be within 1 inch (25.4 mm) from top of reservoir. If hydraulic fluid is required, use John Deere All-Weather Hydrostatic Fluid or an equivalent Type "F" automatic transmission fluid.

Group 20 TUNE-UP AND ADJUSTMENTS

PURPOSE OF TUNE-UP AND ADJUSTMENTS

Generally, the customer complaint will reveal which system or component requires checking. However, when dealing with the entire tractor, it is recommended that the step-by-step procedures outlined on the following pages be used.

VISUAL INSPECTION

Much can be learned about the general condition of the tractor by a thorough visual inspection. For convenience, remove the side panels and hood.

Check the engine, transaxle and hydraulic system (if so equipped) for evidence of oil leakage.

Inspect battery for excessive corrosion, cracked case, proper installation and cable connections. Note general condition of wiring harness. Be sure the harness is not oil-soaked and that it is not frayed or damaged.

ENGINE TUNE-UP

Engine tune-up is making minor repairs and adjustments in an orderly sequence to improve the overall efficiency and operation of the engine.

Tune-up includes checking, adjusting and servicing the electrical, ignition, air intake, fuel and lubrication systems.

TRACTOR ADJUSTMENTS

Adjusting tractor components insures that engine horsepower will be utilized in the most efficient manner.

Adjustments to be made on the tractor include: Checking or changing transaxle lubricant, lubricating grease fittings, checking PTO clutch and brake, tractor brakes, belts and equipment.

TUNE-UP GUIDE

The following guide offers an orderly sequence for servicing a tractor that has been running well.

Also use this guide to explain to your customers what a tune-up includes. Be sure to obtain customer permission before performing these services.

1. Clean Engine Shrouds and Cooling Fins
2. Clean or Replace Air Filter Element
3. Clean Fuel Strainer
4. Check and Clean Engine Crankcase Breather
5. Check Spark Plug Gap
6. Check Ignition Breaker Points and Engine Timing
7. Adjust Carburetor
8. Check Engine Speed
9. Change Engine Crankcase Oil
10. Check or Change Transaxle Lubricant
11. Lubricate Grease Fittings
12. Repack PTO Clutch Bearing
13. Service Battery
14. Check Tire Pressure
15. Check Operation and Condition of:
 - (A) Lights
 - (B) Lift System
 - (C) Steering
 - (D) Brakes (PTO Clutch and Tractor)
 - (E) Belts and Equipment

TUNE-UP AND ADJUSTMENTS

1. Clean Engine Shrouds and Cooling Fins

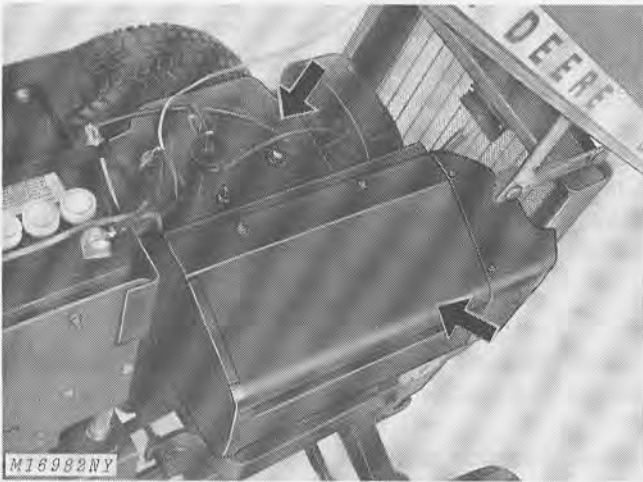

Fig. 1-Engine Shrouds

Remove engine shrouds, Fig. 1. Blow out cooling fins with compressed air. Be sure all dirt and debris are removed from the engine.

2. Clean or Replace Air Filter Element

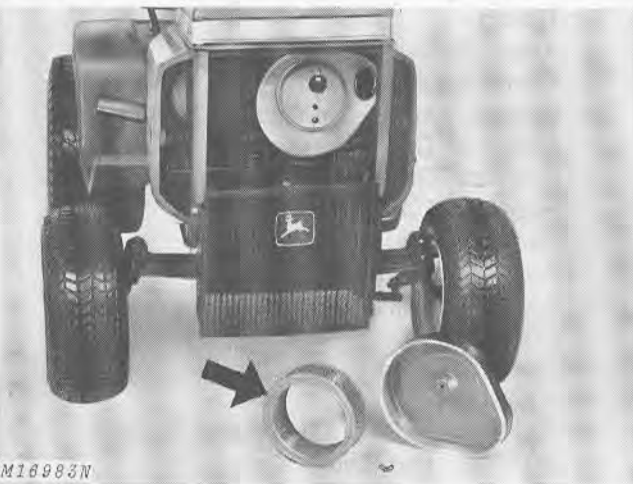

Fig. 2-Air Filter Element

Remove the air filter element, Fig. 2. Tap the filter lightly against a flat surface and brush out dust. Do not clean filter with a liquid cleaner or compressed air.

Replace filter if it is bent, crushed, damaged or extremely dirty.

3. Clean Fuel Strainer

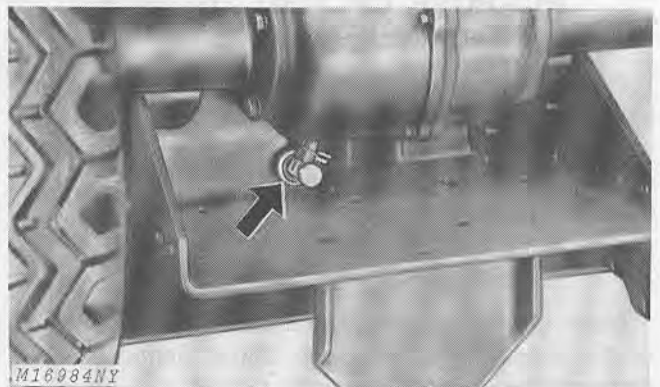

Fig. 3-Fuel Shut-Off Valve

Close the fuel shut-off valve, under fuel tank, Fig. 3. Disconnect hose from valve. Attach a 12-inch length of 1/4-inch hose and drain fuel tank into a clean container.

Remove hose from valve. Unscrew shut-off valve with strainer from fuel tank. Thoroughly clean all particles from strainer.

Install shut-off valve and strainer assembly. Close the valve, connect the hose, and fill fuel tank.

4. Check and Clean Engine Crankcase Breather

A clogged crankcase breather can cause positive pressure to build up in the crankcase.

Check crankcase vacuum with a U-tube water manometer.

An engine in good condition and operating at normal temperatures will show a 5 to 10-inch water column on the manometer.

An engine in good condition and operating at normal engine temperatures will show a 5 to 10-inch water column of vacuum or negative pressure on the manometer, (see Fig. 4).

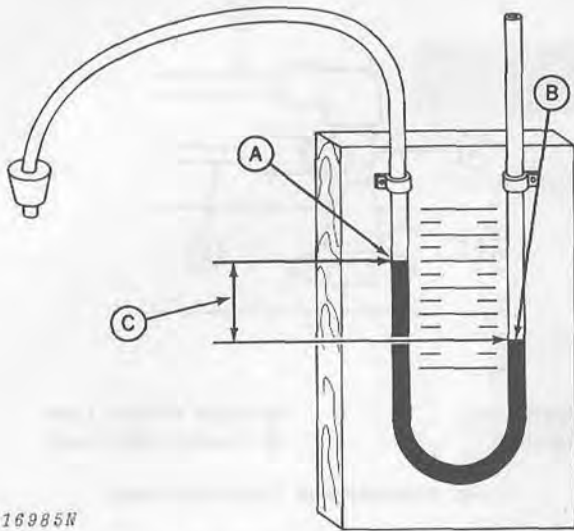

M16985R

A—Negative Pressure B—Positive Pressure
C—Difference Between Columns

Fig. 4-U-Tube Water Manometer

When using manometer, Fig. 4, place stopper into oil fill hole (other end open to atmosphere) and measure difference between columns (C).

If water column is higher in tube connected to engine, vacuum or negative pressure (A) is indicated. If the higher column is on the atmospheric side of manometer, positive pressure (B) is present.

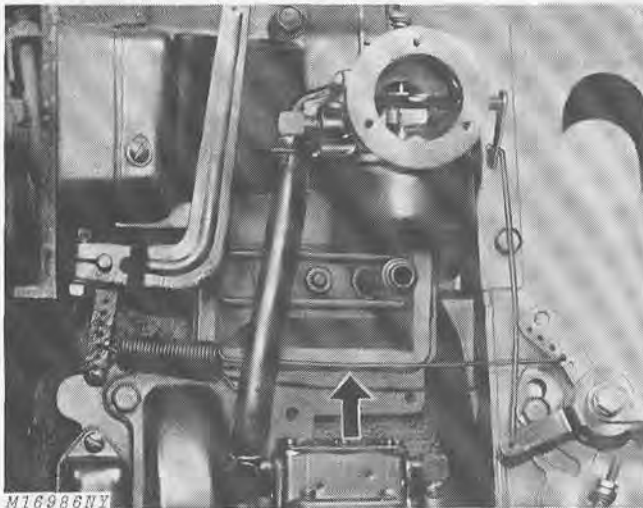

Fig. 5-Engine Crankcase Breather

Disassemble breather assembly, Fig. 5, and clean it thoroughly. Reinstall breather assembly and recheck pressure.

5. Check Spark Plug Gap

Remove spark plug, check condition and reset gap, page 10-10-1.

Good operating conditions are indicated if plug has light gray or tan appearance. A dead white appearance could indicate overheating. A black (carbon) appearance may indicate an "over-rich" fuel mixture, clogged air cleaner or improper carburetor adjustment.

Do not service a plug in poor condition. Install a new plug and torque it to 18 to 22 ft-lbs (24 to 30 Nm). See page 10-10-1.

6. Check Ignition Breaker Points and Engine Timing

Replace badly burned or pitted breaker points. If points are oxidized, rub a piece of coarse cloth across the surfaces. Clean dirty or oily points with a cloth, but make sure no particles of lint are left between the surfaces.

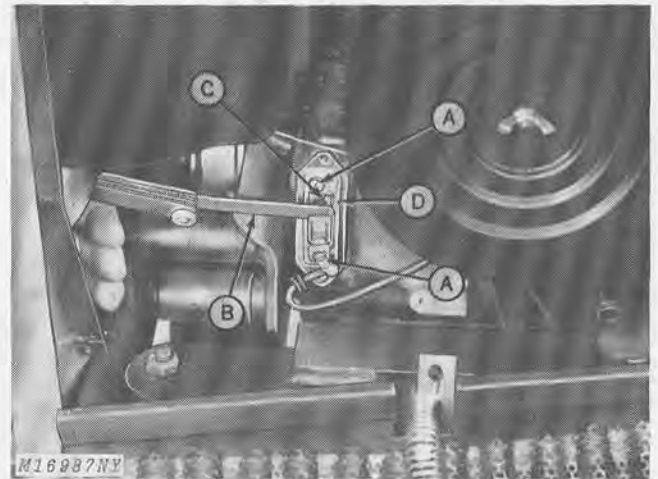

A—Retaining Screws C—Locking Screw
B—Feeler Gauge D—V-Slot

Fig. 6-Replacing and Adjusting Points

To replace points, remove retaining screws (A), Fig. 6. Be sure lock washers are in place when installing new points.

To adjust breaker points, rotate engine until "T" mark on flywheel lines up with indicator, Fig. 8. Use feeler gauge (B, Fig. 6) to measure gap for 0.020-inch (0.508 mm) clearance when points are fully open.



Fig. 7-Adjusting Points

If necessary, loosen locking screw (C, Fig. 6) and move screwdriver in V-slot, Fig. 7, until gap is 0.020-inch (0.508 mm). Gap setting can vary from 0.018 to 0.022-inch (0.457 to 0.588 mm) to achieve smoothest running. Tighten locking screw securely after adjusting gap.

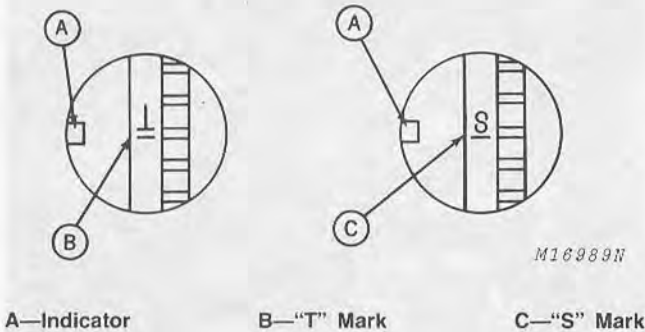

A—Indicator B—"T" Mark C—"S" Mark

Fig. 8-Timing Sight Hole

The timing sight hole is in the engine blower housing. Two timing marks are stamped on the flywheel. The "T" mark (B) indicates top dead center (TDC) and the "S" mark (C) indicates the spark point. Line under the timing marks should line up with the indicator (A), Fig. 8.

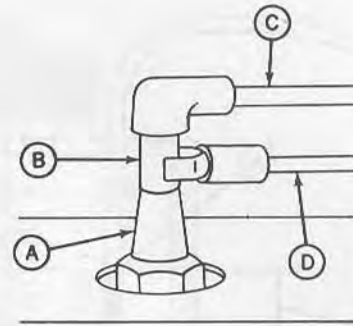

M16990N

A—Spark Plug C—High Tension Lead
B—Adapter D—Timing Light Lead

Fig. 9-Adapter and Timing Light Lead

Remove high tension lead (C) at spark plug (A). Install a spark plug adapter (B) and re-connect high tension lead (C). Connect one timing light lead (D) to the spark plug adapter, Fig. 9.

Connect second timing light lead to the positive battery terminal. See timing light instructions for battery size, wiring, etc.

Connect third timing light lead to ground.

Rotate engine by hand until "S" mark is visible through timing sight hole. Chalk "S" line for easy reading.

Start and run engine at 1700 to 1900 rpm idle speed. The timing light should flash as "S" mark lines up with indicator in timing sight hole.

If timing is off, loosen locking screw and adjust points as shown in Fig. 7 until the "S" mark lines up with indicator in timing sight hole.

Retighten locking screw before replacing breaker point cover.

7. Adjust Carburetor

⚠ CAUTION: Prevent burns. Do not touch engine shrouds or muffler shield if engine has been running.

Idle adjustment and high-speed adjustment must be made at the same time as each affects the other.

Adjust carburetor as follows:

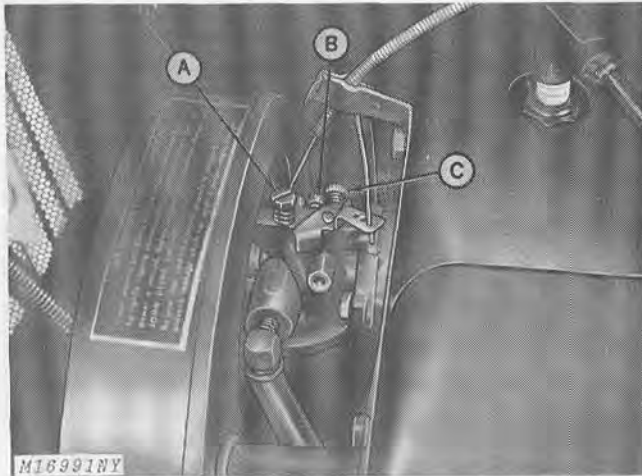

A—High-Speed Mixture Needle
B—Idle Speed Screw
C—Idle Mixture Needle

Fig. 10-200 Tractor Carburetor

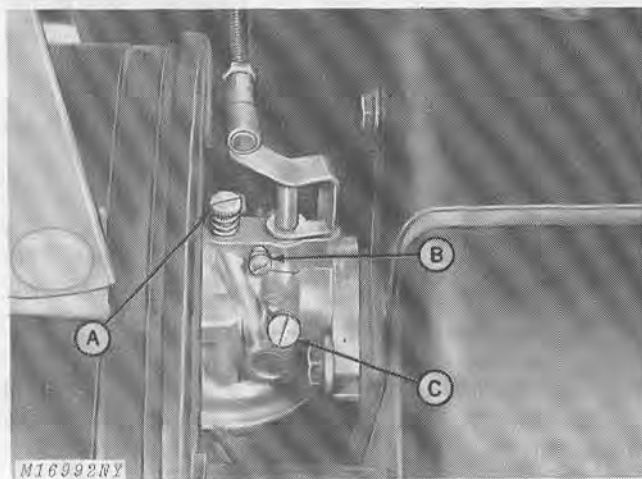

A—High-Speed Mixture Needle
B—Idle Speed Screw
C—Idle Mixture Needle

Fig. 11-210, 212 and 214 Tractor Carburetor

1. Turn high-speed mixture needle (A), Figs. 10 or 11, clockwise until lightly seated. Close finger-tight only. Then open 1-1/2 turns.

2. Turn idle mixture needle (C) clockwise until lightly seated. Close finger-tight only. Then open 2 complete turns.

3. Start engine and raise throttle lever on dash panel to "FAST" position. Allow engine to warm up.

4. Turn high-speed mixture needle (A) 1/8 turn each time, clockwise or counterclockwise, until engine runs smoothly at full throttle (3400 to 3500 rpm).

5. Move throttle lever to "SLOW" position and turn idle mixture needle (C) 1/8 turn each time, clockwise or counterclockwise, until engine runs smoothly (1700 to 1900 rpm).

6. Advance throttle lever quickly to check for uniform acceleration. If engine misses, fuel-air mixture is too lean. Turn high-speed mixture needle (A) counterclockwise until positive acceleration can be obtained.

7. If excessive exhaust smoke is noticed, mixture is too rich. Readjust idle mixture needle (C), until engine idles smoothly at 1700 to 1900 rpm.

8. Check Engine Speed



Fig. 12-Checking Engine Speed With Vibration Tachometer

Use a vibration tachometer, Fig. 12, to check engine for a slow idle speed of 1700 to 1900 rpm and a full throttle speed of 3400 to 3500 rpm.

If carburetor adjustments do not give correct engine speed, adjust governor linkage. See Section 30, Group 10.

9. Change Engine Crankcase Oil

Refer to page 10-15-3.

10. Check or Change Transaxle Lubricant

Refer to page 10-15-3. Lubricant level should be level with the filler hole.

11. Lubricate Grease Fittings

Refer to page 10-15-2.

12. Repack PTO Clutch Bearing

Refer to page 10-15-4.

13. Service Battery

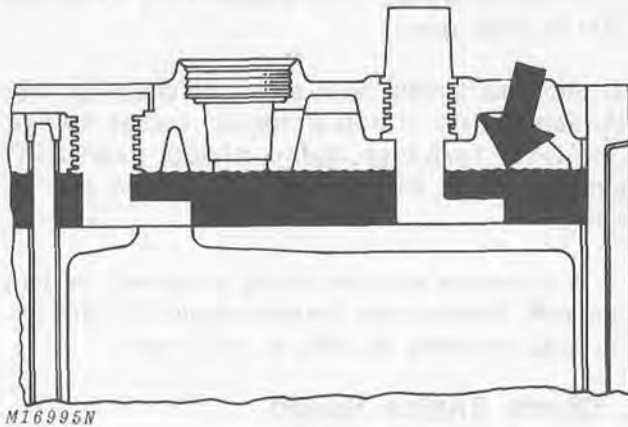

Fig. 13-Battery Electrolyte Level

Check electrolyte level of each cell. Cells should be completely covered. If necessary, fill each cell with distilled water to top of split ledge in the filler tube, Fig. 13.

To clean battery remove battery cables (negative cable, first). Use a wire brush to remove corrosion around battery terminals.

Use a solution of one part baking soda to four parts water to clean battery terminals and cables. Do not allow solution to enter battery cells.

Wash entire battery case, platform and hold-down parts with clear water and wipe dry.

Coat battery terminals with petroleum jelly and connect battery cables (positive cable, first). Be sure both cables are tight.

Charge battery as necessary.

CAUTION: Hydrogen and oxygen gases in the battery are very explosive. Keep open sparks or flames away from battery at all times, especially when charging the battery. Do not smoke around a charged battery. Keep vent holes in cell caps open.

14. Check Tire Pressure

Inflate tires as shown in chart below.

Use high readings for heavy front loads such as loaders; mid-range readings for blades and snow throwers and low readings for normal lawn use.

TIRE INFLATION PRESSURES		
Tire	Front	Rear
High-Flotation Tires (GT-3 Tractor)	16 x 6.50-8 6 to 16 psi (28.7 to 76.6 bar)	23 x 8.50-12 5 to 10 psi (23.9 to 47.8 bar)
Traction Tires (GT-4 Tractor)	4.80 x 4.00-8 12 to 40 psi (57.4 to 191.5)	23 x 8.50-12 5 to 10 psi (23.9 to 47.8 bar)
High-Flotation Tires	16 x 6.50-8 6 to 16 psi (28.7 to 76.6 bar)	23 x 10.50-12 5 to 10 psi (23.9 to 47.8 bar)
Traction Tires (GT-8 Tractor)	16 x 6.50-8 6 to 16 psi (28.7 to 76.6 bar)	23 x 10.50-12 5 to 10 psi (23.9 to 47.8 bar)

15. Check Operation and Condition of:

A. Lights - Replace bulbs or wiring as necessary.

B. Lift System - Check manual, electric or hydraulic lift for proper function. Once a week or every 50 hours of operation check hydraulic fluid level. Hydraulic fluid level should be within 1 inch (25.4 mm) from top of reservoir. Use John Deere All Weather Hydrostatic Fluid or an equivalent Type "F" Automatic Transmission Fluid.

C. Steering - Refer to Section 70 for steering gear adjustment if required.

D. Brakes (PTO Clutch and Tractor) - PTO Brake adjustment was covered under Item 12-"Repack PTO Clutch Bearing." For tractor brake adjustments (if required) refer to Section 50.

E. Belts and Equipment - Clean belts by wiping them with a clean cloth. Do not use solvents. Solvents will soften the material and cause belts to grab.

Section 20

ENGINE

Group 5

GENERAL INFORMATION AND DIAGNOSIS

CONTENTS

	Page		Page
GROUP 5 - GENERAL INFORMATION		Inspection and Repair	15-4
Description	5-3	Piston and Piston Rings	15-4
Engine Analysis	5-4	Inspecting Connecting Rod and Cap	15-8
Preliminary Engine Checks	5-4	Inspecting Crankshaft Journal and	
Preliminary Engine Tests	5-4	Connecting Rod Clearance	15-8
Compression Test	5-4	Inspecting Cylinder	15-9
Crankcase Vacuum Test	5-5	Deglazing Cylinder	15-9
Diagnosing Malfunctions	5-6	Assembly	15-10
 GROUP 10 - CYLINDER HEAD, VALVES		Installing Piston Pin	15-10
AND BREATHER		Installing Piston Rings	15-10
General Information	10-1	Installing Piston and Connecting Rod	15-10
Disassembly	10-2	Installing Oil Pan	15-11
Disassembling Engine	10-2	Installing Cylinder Head	15-11
Removing Valves	10-3	Installing Engine in Tractor	15-12
Valve Analysis	10-3	Run-In Procedure	15-12
Inspection and Repair	10-4	 GROUP 20 - MAJOR ENGINE	
Inspecting Cylinder Head	10-4	RECONDITION	
Inspecting Breather	10-5	General Information	20-1
Inspecting Valve Springs	10-5	Automatic Compression Release (ACR)	
Inspecting Valves and Valve Guides	10-5	Camshaft	20-2
Replacing and Reaming Valve Guides	10-6	Disassembly	20-3
Reconditioning Valves and Seats	10-7	Removing Engine	20-4
Replacing Exhaust Valve Insert	10-7	Engine Support Stand	20-4
Lapping Valves	10-8	Minor Engine Reconditioning	20-4
Adjusting Valve Clearance	10-8	Short Block Installation	20-4
Checking Valve Lift	10-9	Removing Exterior Components	20-5
Installation	10-9	Removing Valves	20-5
Installing Valves	10-9	Removing Cylinder Ridge	20-5
Assembling Breather	10-10	Removing Piston and Connecting Rod	20-6
Installing Cylinder Head	10-10	Removing Piston Rings and Pin	20-6
Installing Carburetor and Governor Linkage	10-10	Removing Flywheel	20-6
 GROUP 15 - MINOR ENGINE		Removing Bearing Plate	20-6
RECONDITION		Removing Crankshaft	20-7
General Information	15-1	Removing Camshaft	20-7
Disassembly	15-2	Removing Governor Assembly	20-7
Removing Engine	15-2	Inspection and Repair	20-8
Removing Cylinder Ridge	15-3	Inspecting Connecting Rod and Cap	20-8
Removing Piston and Connecting Rod	15-3	Inspecting Crankshaft Journal and	
Removing Piston Rings and Pin	15-3	Connecting Rod Clearance	20-8
		Inspecting and Repairing Cylinder Block	20-9
		Deglazing Cylinder Bore	20-10
		Boring Cylinder Block	20-10

CONTENTS—Continued

	Page		Page
Inspecting Main Bearings	20-11	Installing Piston Rings	20-16
Inspecting Camshaft and Camshaft Pin ...	20-12	Installing Piston and Connecting Rod	20-16
Inspecting and Repairing Governor Assembly	20-12	Installing Oil Pan	20-17
Inspecting Cross Shaft Assembly	20-13	Installing Valves and Breather Assembly ..	20-17
Replacing Ring Gear	20-13	Installing Cylinder Head	20-17
Assembly	20-13	Installing Flywheel	20-18
Assembling Governor Assembly	20-13	Installing Exterior Components	20-18
Installing Crankshaft Bearings	20-14	Installing Engine in Tractor	20-19
Installing Camshaft	20-14	Run-In Procedure	20-19
Installing Crankshaft	20-14		
Installing Bearing Plate	20-15	GROUP 25 - SPECIFICATIONS	
Installing Oil Seals	20-15	Specifications	25-1
Installing Piston Pin	20-16	Torques For Hardware	25-3

DESCRIPTION

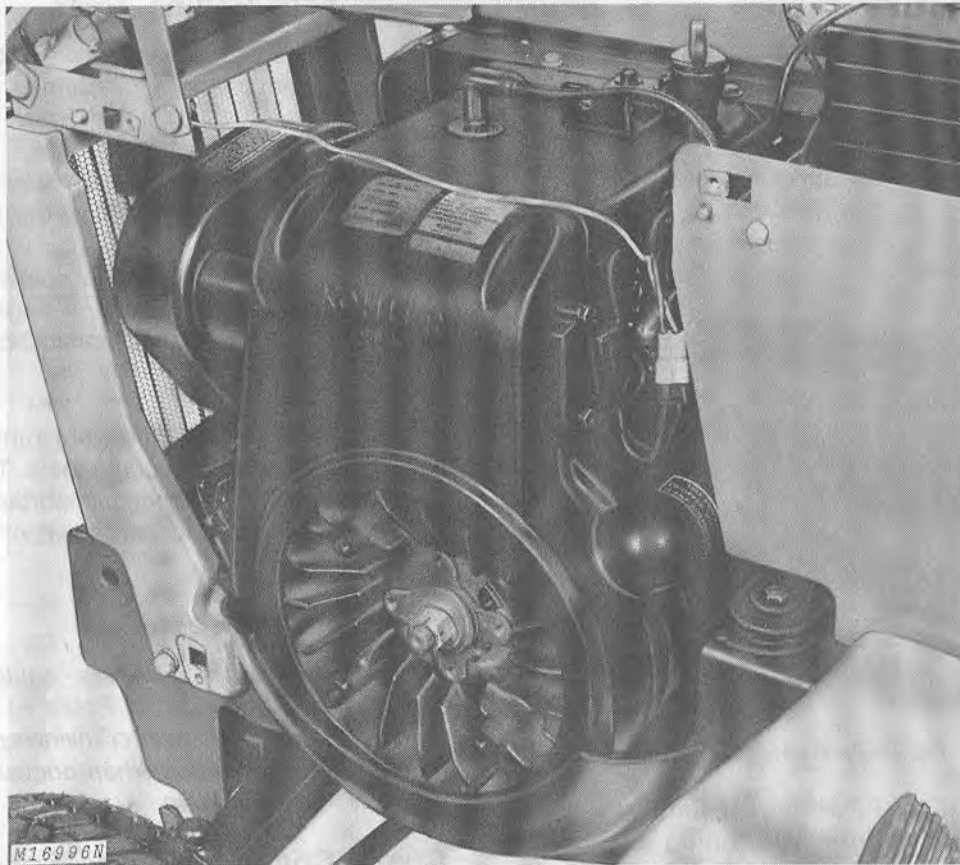

Fig. 1-Kohler Engine

Kohler engines, Fig. 1, are used in the 200 Series Tractors. The tractors with their respective engines are as follows:

- 200 Tractor - K181QS - 8hp
- 210 Tractor - K241AQS - 10hp
- 212 Tractor - K301AQS - 12hp
- 214 Tractor - K341AQS - 14hp

Each of the four-cycle, L-head, single-cylinder, internal combustion engines has a cast-iron block with a large bore and short stroke.

These air-cooled engines feature anti-friction ball bearings, oil bath lubrication, internal flyweight governors, an alternator charging system and battery-coil ignition.

ENGINE ANALYSIS

Preliminary Engine Checks

The majority of engine problems are usually due to electrical or fuel system difficulties. Make the following checks and tests to isolate the engine problem. Refer to "Diagnosing Malfunctions" if the following checks and tests do not solve the problem.

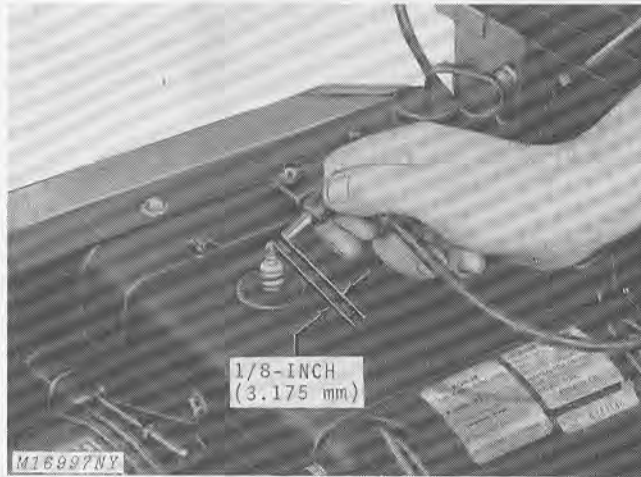

Fig. 2-Checking Spark

Check spark, Fig. 2, whenever engine will not start. Remove cable from spark plug and install adapter. Hold adapter approximately 1/8-inch (3.175 mm) away from spark plug terminal while cranking engine.

No spark or a weak spark between the adapter and spark plug terminal indicates trouble in the electrical system.

Check the battery, spark plug and all electrical connections. If these are in good condition, the trouble is probably with the breaker points or condenser.

Clean or replace points and adjust gap. If breaker points are burned, replace points and condenser.

Preliminary Engine Tests

If a good spark exists between the adapter and spark plug terminal, the problem is in the fuel system.

Check fuel tank and lines. Be sure shut-off valve is open and that fuel is reaching the carburetor.

Connect spark plug wire to spark plug and crank engine. Choke as necessary. If engine still does not start, refer to "Diagnosing Malfunctions" to check for internal difficulties.

If engine starts but does not run properly, make the compression and vacuum tests. The compression and vacuum tests are very important when the engine runs erratically, loses power, or uses an excessive amount of oil.

Compression Test

NOTE: Kohler engines are equipped with ACR (Automatic Compression Release). ACR relieves compression during lower cranking speeds. The ACR mechanism disengages when engine speed reaches approximately 650 rpm.

Check Compression as Follows:

1. Depress brake pedal and set parking brake.
2. Check crankcase for proper oil level. Add oil if necessary.
3. Disengage all tractor drives. Run engine until warm, then stop the engine.
4. Remove spark plug and air filter. Removing the air filter gives a more accurate test.
5. Set throttle and choke in wide open positions by raising throttle lever and pulling out the choke knob.

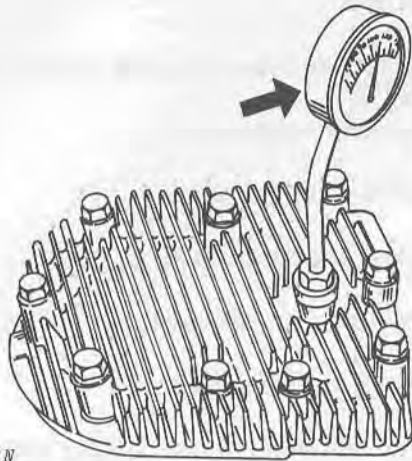

M16998N

Fig. 3-Testing Engine Compression

6. Hold compression gauge firmly in spark plug hole, Fig. 3.

7. Wind a 1/4-inch (6.350 mm) rope around the PTO sheave opposite the direction of engine rotation. Pull rope firmly and observe reading. Repeat this test to obtain a consistent or average reading.

NOTE: The rope method must be used to check compression. The starter will not turn the engine fast enough (1000 rpm) to overcome the ACR. Turning the engine in the opposite direction of rotation will by-pass the ACR.

8. Compression pressure should be 110 to 120 psi at approximately 1000 rpm. Pressure above 120 psi indicates excessive carbon deposits in the combustion chamber or on the piston. Pressure below 100 psi indicates leakage at the cylinder head gasket, piston rings or valves. If compression is below 90 psi, recondition the engine.

9. To determine if the rings or valves are at fault, pour about one tablespoon of heavy oil in the spark plug hole. Crank the engine several times to spread the oil.

10. Repeat the compression test. If the same compression reading is obtained, the rings are satisfactory, but the valves are leaking or the piston is damaged. If the compression has increased considerably over the original reading, then the rings are bad and must be replaced.

Crankcase Vacuum Test

The purpose of the vacuum test is to determine if the crankcase breather is maintaining a partial vacuum in the engine crankcase. The engine must be running properly for the breather to function correctly.

Test the engine as follows:

1. Warm up the engine.

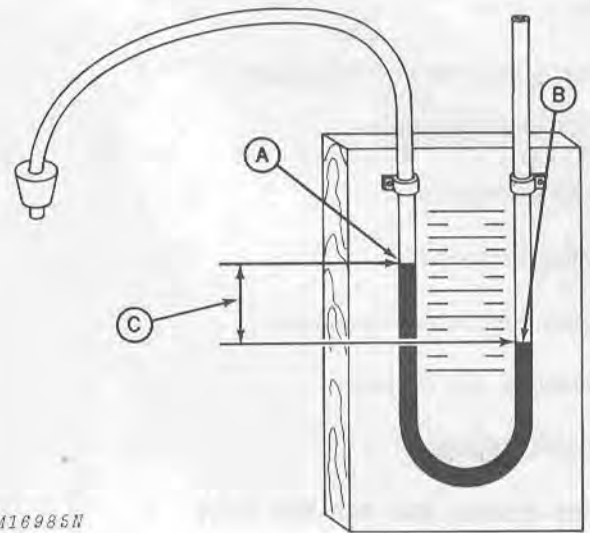

M16985N

A—Vacuum
B—Pressurization
C—Difference Between Columns

Fig. 4-U-Tube Water Manometer

2. Connect a U-tube water manometer, Fig. 4, to the oil filler tube. Be sure tester is hanging vertically.

3. Start and run the engine at idle speed (1700-1900 rpm). Observe reading on scale.

4. Proper crankcase pressure for the Kohler engines is a 10 to 15-inch water column on the gauge. Follow manufacturer's recommendations and compensations for the effect of altitude on the gauge reading.

5. A low vacuum reading is probably due to a leaking breather valve or improperly assembled breather. Leaky valves, engine blow-by or worn crankshaft oil seals can also cause a low reading.

6. If the crankcase shows pressurization (B) rather than a vacuum (A), the breather plate has probably been assembled backwards or the breather filter is plugged.

7. If the engine shows zero vacuum (A) or a pressurized crankcase (B), oil is being pumped into the combustion chamber or out the breather or oil seals. This is detectable by excessive exhaust smoke, engine overheating or oil leakage.

DIAGNOSING MALFUNCTIONS

Engine Will Not Crank

- Battery discharged or defective.
- Neutral-start switch and bracket loose, defective, or not properly adjusted.
- PTO safety start switch out of adjustment or defective.
- Seat safety start switch defective.
- PTO drive engaged.
- Defective starter.
- Defective solenoid.
- Loose electrical connections.
- Defective key switch.
- Engine seized.

Engine Cranks But Will Not Start

- Empty fuel tank.
- Restricted fuel tank vent.
- Fuel shut-off valve closed (valve below fuel tank).
- Clogged, restricted, or air-locked fuel line.
- Defective fuel pump.
- Breaker points worn or pitted.
- Spark plug fouled or pitted.
- Loose electrical connections.
- Faulty condenser.
- Defective ignition coil.
- Frayed wire (s) causing ground (s).

Engine Starts Hard

- Spark plug pitted or fouled.
- Breaker points worn, pitted, or out of adjustment.
- High-tension wire shorted.

- High-tension wire loose at spark plug or coil.
- Loose electrical connections.
- Restricted fuel tank vent.
- Clogged fuel line or air lock.
- Broken choke or throttle cable.
- Dirt or water in fuel system.
- High-speed and idle mixture needles not properly adjusted.
- Air leakage at carburetor.
- Head gasket leaking.
- Low compression.

Engine Starts But Fails to Keep Running

- Restricted fuel tank vent.
- High-speed and idle mixture needles not properly adjusted.
- Broken choke cable.
- Dirt or water in fuel system.
- Carburetor float not properly adjusted or leaky float.
- High-tension wire loose at spark plug or coil.
- High-tension wire shorted.
- Breaker points not properly adjusted.
- Loose connections.
- Defective head gasket.
- Faulty condenser.
- Exhaust valve sticking in excessively tight valve guide.
- Breaker points push rod sticking.

Engine Runs But Misses

- High-tension wire loose from spark plug or coil.
- Breaker points out of adjustment or worn and pitted.
- Spark plug fouled or pitted, incorrect gap.
- Loose electrical connections.
- Carburetor float not properly adjusted or leaky float.
- Dirt or water in fuel system.
- Wrong valve clearance.
- Faulty coil.
- Engine shrouding plugged (overheats).

Engine Misses Under Load

- Spark plug fouled or pitted, incorrect gap.
- High-speed and idle mixture needles not properly adjusted.
- Incorrect spark plug.
- Breaker points out of adjustment or worn and pitted.
- Ignition out of time.
- Dirt or water in fuel system.
- Stale fuel.

Engine Will Not Idle

- Idle speed too low.
- Idle mixture needle not properly adjusted.
- Air leakage at carburetor.
- Dirt or water in fuel system.
- Restricted fuel tank filler cap.
- Spark plug fouled or pitted, incorrect gap.
- Wrong valve clearance.
- Low engine compression.

Engine Misses When Advancing Throttle

- Cold engine.
- High-speed and idle mixture needles not properly adjusted.
- Spark plug fouled or pitted, incorrect gap.
- Linkage misaligned (throttle arm-to-governor).

Engine Loses Power

- Crankcase low on oil.
- Engine shrouding plugged (overheats).
- Excessive engine load.
- Restricted air filter.
- Dirt or water in fuel system.
- High-speed and idle mixture needle not properly adjusted.
- Air leakage at carburetor.
- Spark plug fouled or pitted (incorrect gap).
- Too much oil in crankcase.
- Low engine compression.
- Worn cylinder bore.
- Governor defective.
- Governor linkage out of adjustment.

Engine Overheats

- Dirty, plugged, or damaged shrouding or engine fins.
- High-speed and idle mixture needles not properly adjusted.
- Air leakage at carburetor.
- Too much oil in crankcase.
- Crankcase low on oil.
- Excessive engine load.
- Flywheel fins broken or damaged.

DIAGNOSING MALFUNCTIONS—Continued

Engine Knocks

Engine out of time.

Excessive engine load.

Engine overheated.

Engine Uses Excessive Amount of Oil

Clogged or faulty breather assembly.

Breather not assembled properly.

Worn or broken piston rings.

Worn cylinder bore.

Clogged oil holes in piston.

Wrong size piston rings.

Worn valve stems and/or valve guides.

Incorrect oil viscosity.

Engine Runs Erratically or Surges

Dirt or water in fuel system.

High-speed and idle mixture needles not properly adjusted.

Idle speed too low.

Spark plug fouled or pitted (incorrect gap).

Poor compression.

Faulty breather causing low crankcase vacuum.

Carburetor leaking at gaskets or at connection.

Restricted fuel tank vent.

Throttle-to-governor linkage improperly adjusted.

Governor defective.

Breaker points out of adjustment, worn or pitted.

Gasoline in Crankcase

Carburetor float not properly adjusted or leaking.

Float valve and/or seat leaking.

Engine Backfires

High-speed and idle mixture needles not properly adjusted.

Air leakage at carburetor.

Loose cylinder head or blown head gasket.

Intake valve sticking in guide.

Ignition out of time.

Group 10 CYLINDER HEAD, VALVES AND BREATHER

GENERAL INFORMATION

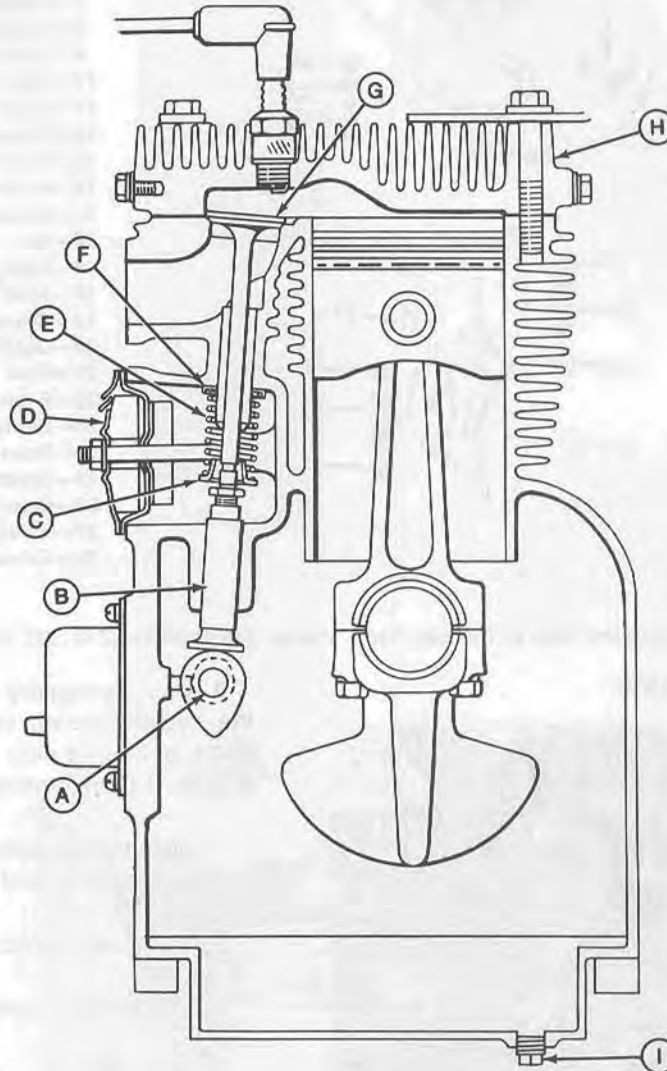

M16999N

A—Camshaft
B—Tappet
C—Retainer

D—Breather Assembly
E—Valve Spring
F—Spring Retainer

G—Intake Valve
H—Cylinder Head
I—Drain Plug

Fig. 1-Schematic View of Cylinder Head, Valves and Breather

It is not necessary to remove the engine to lap or grind valves, valve seats or service the breather.

The 210, 212 and 214 Tractors have an exhaust valve rotator. Whenever the valves are removed, be sure that the correct valve spring is used with the rotator on the exhaust valve.

The exhaust valve insert, which is a press fit into the block, can be replaced. The intake valve seat is machined into the block.

Valve guides can be replaced when wear tolerances are exceeded.

Exterior governor linkage can be adjusted for high-speed setting and sensitivity.

DISASSEMBLY

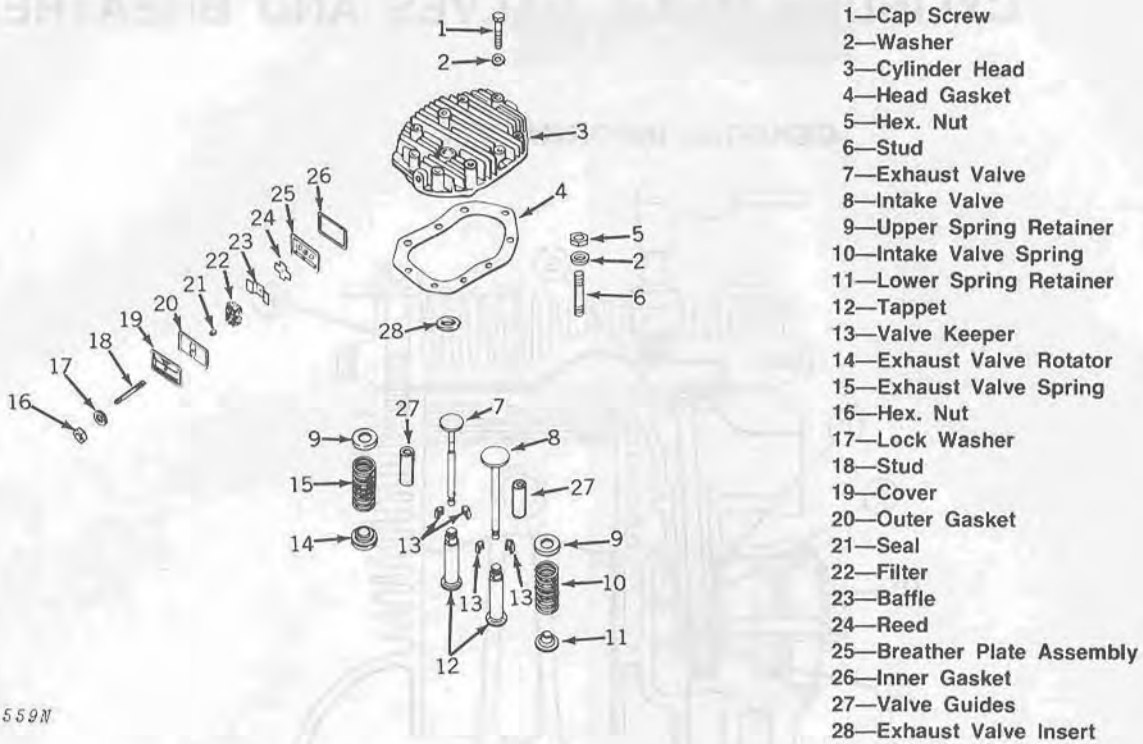

- 1—Cap Screw
- 2—Washer
- 3—Cylinder Head
- 4—Head Gasket
- 5—Hex. Nut
- 6—Stud
- 7—Exhaust Valve
- 8—Intake Valve
- 9—Upper Spring Retainer
- 10—Intake Valve Spring
- 11—Lower Spring Retainer
- 12—Tappet
- 13—Valve Keeper
- 14—Exhaust Valve Rotator
- 15—Exhaust Valve Spring
- 16—Hex. Nut
- 17—Lock Washer
- 18—Stud
- 19—Cover
- 20—Outer Gasket
- 21—Seal
- 22—Filter
- 23—Baffle
- 24—Reed
- 25—Breather Plate Assembly
- 26—Inner Gasket
- 27—Valve Guides
- 28—Exhaust Valve Insert

M11559N

Fig. 2—Exploded View of Cylinder Head, Valves, and Breather (210, 212 and 214 Tractors)

Disassembling Engine

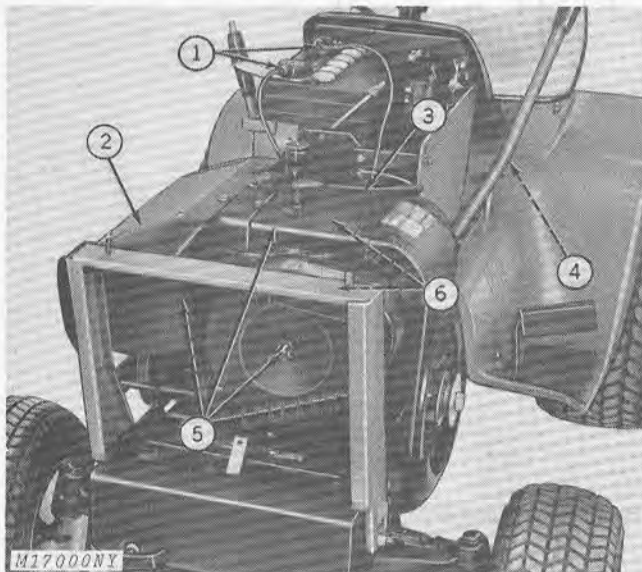
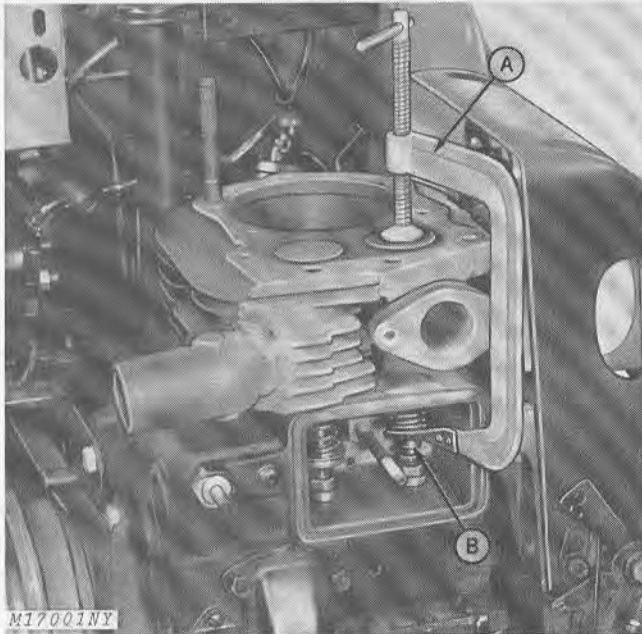

Fig. 3—Disassembling Engine

It is not necessary to remove the engine to service the cylinder head, valves or breather. Remove the hood, grille and side panels to provide access to the engine. Clean engine exterior prior to disassembly.

1. Disconnect battery cables, negative cable first. Remove battery and battery box.
2. Remove shroud covering muffler.
3. Disconnect wiring from coil to wiring harness.
4. Shut off fuel.
5. Remove engine shrouding, coil, carburetor, governor linkage and muffler.
6. Remove cylinder head, breather assembly and valves.

Removing Valves



A—Valve Spring Compressor B—Valve Keepers

Fig. 4-Removing Valves

Use a valve spring compressor (A) to compress valve springs, Fig. 4. Remove valve keepers (B) from valve stems with a magnet. Remove valves.

Remove valve spring retainers and valve springs from valve chamber. Note the rotator-type retainer on the exhaust valve spring of the K241AQS, K301AQS and K321AQS engines. This spring is shorter than the intake valve spring.

VALVE ANALYSIS

Analyze valve condition before cleaning, grinding or discarding.

Lead deposits on the intake valve, Fig. 5, consist of lead and metal from the lubricating oil. These deposits are caused by a small amount of exhaust gas leakage into the intake port area. This indicates the valve is not seating properly. Grind the valve and re-face the seat to correct this condition.

NOTE: Be sure to readjust valve clearance after grinding valves. See page 20-10-8.



Fig. 5-Lead Deposits on Leaky Intake Valve

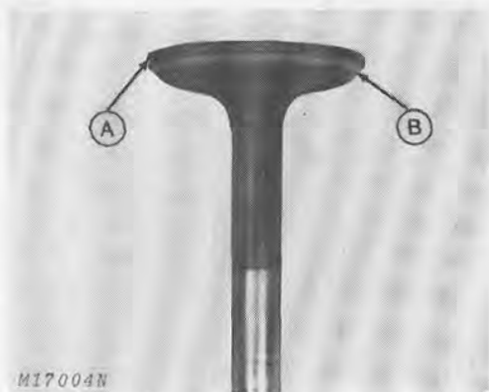

Fig. 6-Valve Stem Corrosion

Valve stem corrosion, Fig. 6, is caused by moisture entering the engine. Moisture in the fuel-air mixture will condense inside the engine when the engine is stopped prior to warm up.

Valve corrosion will occur during storage when the engine has been idle for some time. Fogging or pouring oil in the combustion chamber before storing tractor will prevent valve corrosion.

Corroded and pitted valves tend to collect deposits which cause valve sticking. Always replace badly corroded or pitted valves with new valves.



A—Margin B—Face

Fig. 7—Exhaust Valve Running Too Hot

Exhaust valves are designed to function in temperatures exceeding 5000°F (2760°C). However, when operating at this temperature for long periods of time, valve burning occurs, Fig. 7. Valves running too hot will show dark discoloration of the valve stem down in the area protected by the valve guide. Another indication is distortion of the valve margin (A) and valve face (B). Valve inserts may also begin to burn away.

The common cause of an overheated engine and valves is poor cooling due to dirt or obstructions in the shrouding and cooling fins. Remove and clean shrouding and all cooling fins if this condition is noticed.

NOTE: Do not run the engine with shrouding removed.

Valves running hot may also be due to an improper spark plug, lean fuel mixture, worn valve guides or weak valve springs.

Check valve timing and valve clearance. Adjust as necessary.

Stale gasoline which has been in the fuel tank a long time is a common cause of sticking valves, Fig. 8.

The gummy substance from the gasoline can be seen on the valve. When this condition exists, the carburetor will also contain gum deposits and require a complete cleaning.

Advise customer to use fresh gasoline. Drain gas from all lines and the carburetor before storing tractor.



Fig. 8—Gummy Valve Causing Valve to Stick

INSPECTION AND REPAIR

Inspecting Cylinder Head

Remove carbon deposits from combustion chamber and gasket surface of head with a scraper. Be careful not to damage the cylinder head gasket surface. Use a safe cleaning solvent to remove dirt, grease, and other deposits.

Check the cylinder head for cracks and broken cooling fins. Inspect the gasket surface for burrs and nicks. Replace the head if any of these conditions are found.

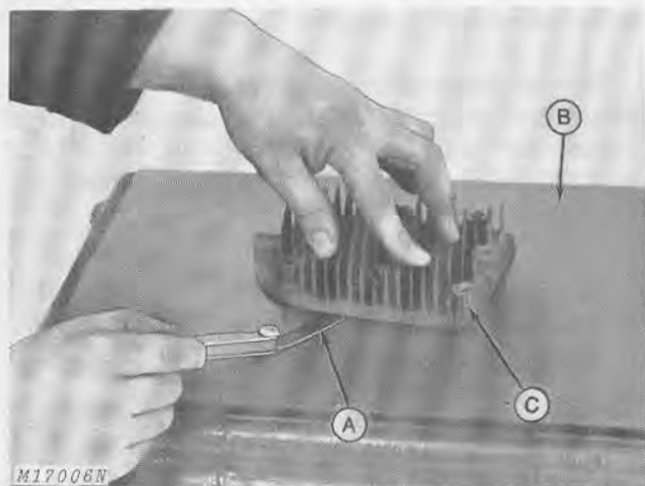

A—Feeler Gauge B—Surface Plate C—Cylinder Head

Fig. 9—Checking Surface of Cylinder Head

When a cylinder head (C, Fig. 9) is removed because of gasket leaks, check the flatness of the cylinder head by placing it on a surface plate (B). Use a feeler gauge (A) to see that gasket surfaces make contact at all points. Replace the cylinder head if the machined surface varies by more than 0.003 inch (0.076 mm).

Inspecting Breather

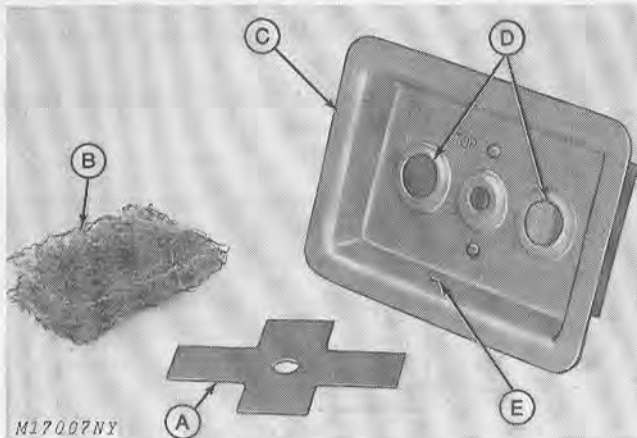

- M17007NY
- A—Reed Valve
 - B—Filter
 - C—Breather Plate Assembly
 - D—Breathing Holes
 - E—Oil Drain Hole

Fig. 10-Inspecting Breather Assembly

Thoroughly clean breather assembly, Fig. 10, in solvent. Replace filter (B) if it cannot be adequately cleaned.

Inspect reed valve (A) for warpage, cracks and damage. Inspect breather plate assembly (C) for pits or burrs around breathing holes (D) that could cause leakage past reed valve (A). Be certain oil drain hole (E) in breather plate assembly (C) is not plugged.

Inspecting Valve Springs

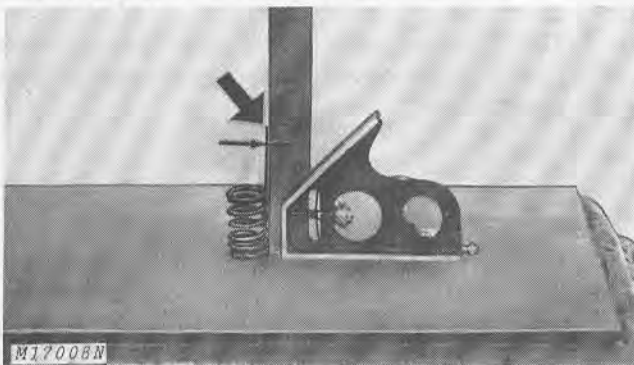

Fig. 11-Valve Spring Squareness (New Spring)

Use a steel square and surface plate to check valve spring for squareness. Stand the spring and square on end on the surface plate. Place the spring next to the square, Fig. 11. Revolve the spring slowly and measure clearance between the top coil and the square. Clearance should not exceed 1/16 inch (1.588 mm).

Check valve springs for free length. Check springs for proper pressure when compressed to a measured length. Refer to "Specifications," page 20-25-2 and 3.

Inspecting Valves and Valve Guides

Valves

Use a power-operated wire brush to remove carbon from valve head, face and stem. Be sure carbon is removed and not just burnished. Any carbon left on the stem will affect alignment in the valve refacer collet.

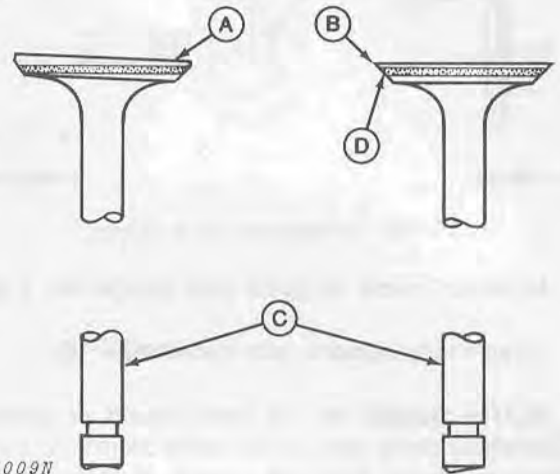

- M17009N
- A—Warped Head
 - B—Margin (none shown)
 - C—Worn Valve Stems
 - D—Face

Fig. 12-Faulty Valves

Inspect valve faces (D), heads (A), and stems (C) for distortion, pitting or burning, Fig. 12. Acceptable valves should be reconditioned.

A distorted valve will become evident when refacing operation is performed. Replace with new valve.

Replace valve if appearance is questionable or margin (B) is less than 1/32 inch (0.794 mm).

Grind valve stem (C) square prior to installation.

Valve Guides

Use the correct size wire brush in an electric drill. Run the brush up and down the full length of the guide. A few drops of light oil or kerosene will help to fully clean the guide.

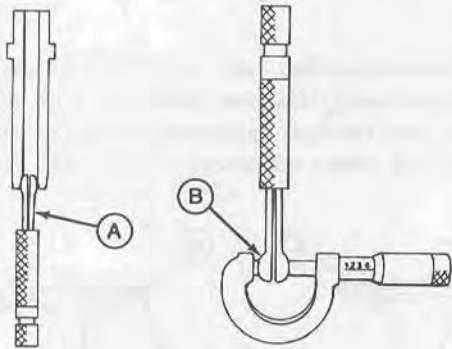

A—Gauge

M17010N

B—Micrometer

Fig. 13-Measuring Valve Guides

Measure inside of guide with gauge (A), Fig. 13.

Read measurement with micrometer (B).

NOTE: Guides do not wear round or uniformly. Therefore, don't use plugs, valve stems or pilots to measure them. Measure guides at different points within the guide as shown in Fig. 13.

Replacing and Reaming Valve Guides

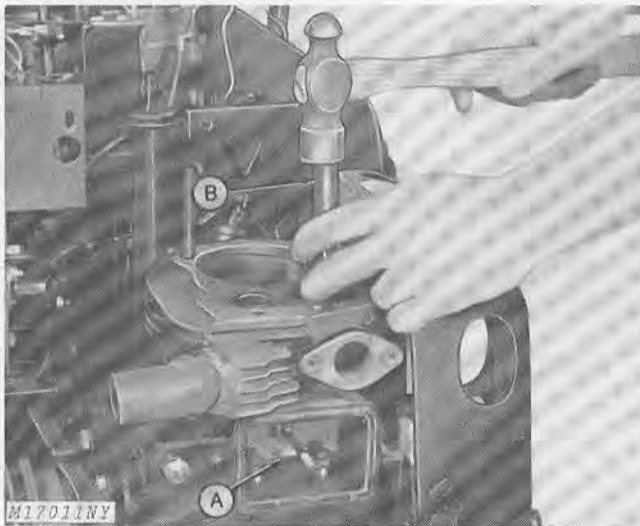

A—Valve Chamber

B—Valve Guide Driver JDM-69

Fig. 14-Removing Valve Guides

Drive valve guide down into valve chamber area (A), Fig. 14. Carefully break protruding end of guide and continue to drive down until guide is removed.

IMPORTANT: Be careful not to damage block when breaking old guides.

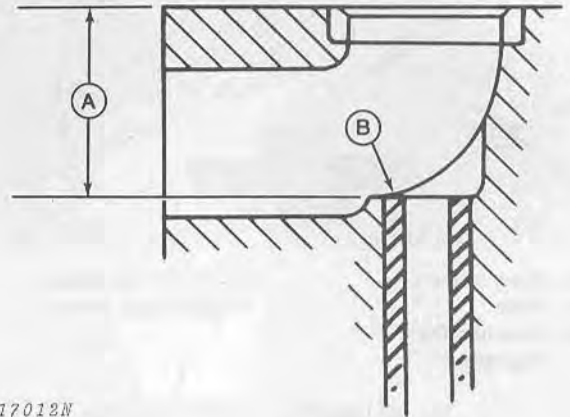

M17012N

A—Guide Depth

B—Guide

Fig. 15-Installing Valve Guides

Thoroughly clean hole and use Valve Guide Driver JDM-69 to carefully drive new guide into cylinder block the recommended distance, Fig. 15.

Ream new guides with an adjustable reamer to provide correct valve guide-to-stem clearance. See "Specifications," page 20-25-2.

NOTE: Exhaust valve stem clearance is critical. Too tight a fit will cause the exhaust valve to "hang up" when hot.

Reconditioning Valves

Reface the valves at 45° on a valve grinder until seating surface is cleaned up. In many cases, valve lapping will be sufficient. See page 10-8.

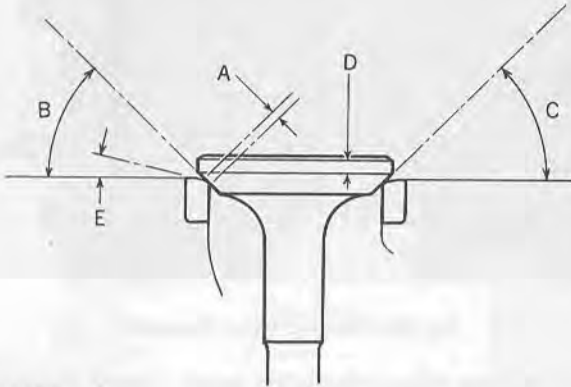

M5507N

- A—Valve Seating Surface (1/32-inch) (0.794 mm)
- B—Valve Seat Angle (45°)
- C—Valve Face Angle (45°)
- D—Valve Margin (1/16-inch) (1.588 mm)
- E—Seat Narrowing Angle (15° or 30°)

Fig. 16—New Valve and Valve Seat Dimensions

If, after grinding, there is less than 1/32-inch (0.794 mm) margin, "D," Fig. 16, the valve must be replaced. Knife edges lead to breakage, burning and pre-ignition because heat localizes on the edge. If margin is uneven after grinding, a warped head is indicated.

Reconditioning Valve Seats

Valve lapping will be sufficient to provide good seating surfaces in many cases. See page 20-10-8.

Broken or excessively burned or pitted exhaust valve seats (inserts) can be replaced. The intake valve seat is machined into the block.

Grind or cut the valve seats at 45° until seating surface is cleaned up. Then narrow (cut back) seat to obtain 1/32-inch (0.794 mm) seating surface (A, Fig. 16). Maximum seating surface width is 1/16-inch (1.588 mm). Narrow seats with a 15° or 30° cutter.

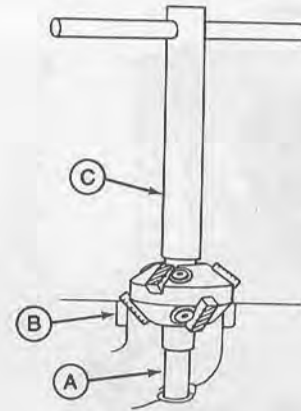

M17013N

- A—Pilot
- B—Valve Seat
- C—Valve Seat Cutter

Fig. 17—Valve Seat Cutter

The valve seat cutter (C, Fig. 17), will cut a 45° valve seat (B) and narrow the seat at 30°. See "Special Tools," Section 80.

Replacing Exhaust Valve Insert

If the exhaust valve insert is pitted or burned to a point that grinding cannot clean up seating surface, it must be replaced.

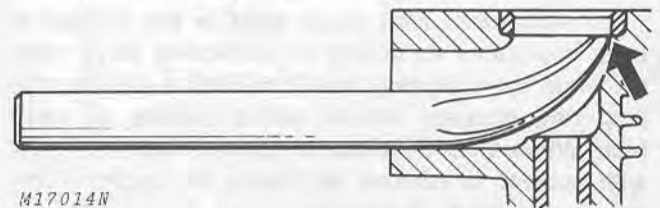

M17014N

Fig. 18—Removing Exhaust Valve Insert

To remove exhaust seat insert, use extractor, Fig. 18, or a valve seat puller. See "Special Tools," Section 80. If extractor is not available, break insert and drive out. Clean seat area thoroughly before installing new insert.

Exhaust valve insert is retained by press fit only. Chill both the insert and driving tool in dry ice before pressing insert into block.

Lapping Valves

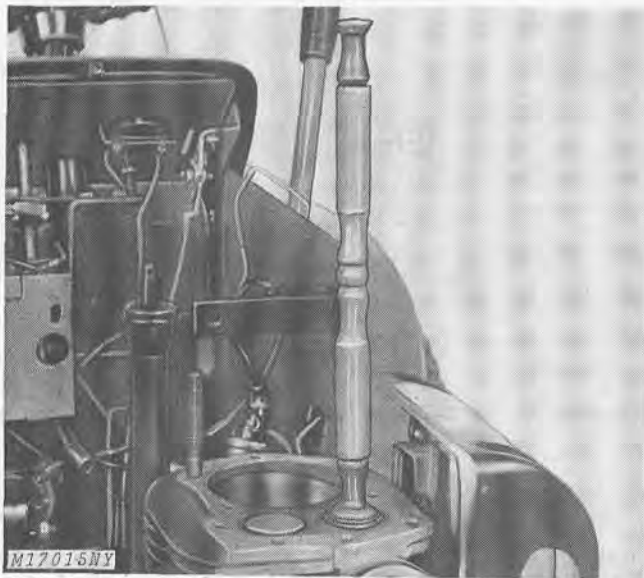

Fig. 19-Lapping Valves

Coat face of valve sparingly with a fine grade of valve grinding compound. Use a vacuum cup tool, Fig. 19, to grip top of valve and rotate valve in an oscillating circular motion on valve seat.

Lift valve from seat every eight or ten strokes to keep compound equalized on surface of valve seat. Continue valve lapping operation until a uniform lapping ring appears around entire surface of valve face. When a good surface is attained, wash all parts with solvent to remove all traces of lapping compound. Dry parts thoroughly.

Note position of valve seat marked on valve face. The lapping mark made by the seat after lapping should appear on or near the center of the valve face.

Adjusting Valve Clearance

Valve grinding changes the tappet and valve clearance. After grinding or installing new valves, check clearance as follows:

1. Place valves, without springs, into valve guides.

2. Rotate crankshaft until piston is at top dead center on the compression stroke. Both valves must be completely closed.

It is important that the piston be in this position to insure that the exhaust valve tappet is not riding on the automatic compression release mechanism.

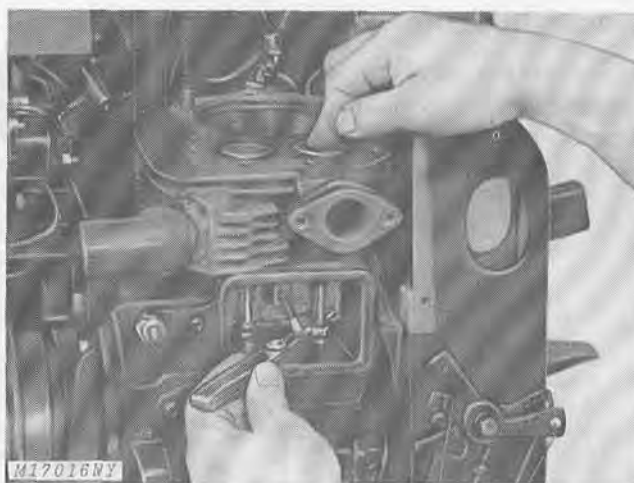

Fig. 20-Checking Valve Clearance

3. Holding valves firmly on seats, check clearance between bottom of each valve stem and its tappet with a feeler gauge, Fig. 20.

Intake valve clearance should be 0.006 to 0.008 inch (0.152 to 0.203 mm) on K181QS engines and 0.008 to 0.010 inch (0.203 to 0.254 mm) on K241AQS, K301AQS and K321AQS engines.

Exhaust valve clearance should be 0.015 to 0.017 inch (0.381 to 0.432 mm) on K181QS engines and 0.017 to 0.020 inch (0.432 to 0.508 mm) on K241AQS, K301AQS and K321AQS engines.



Fig. 21-Adjusting Tappet Clearance

4. (K241AQS, K302AQS and K321AQS engines). With a wrench on the flat area of the tappet and a wrench on the tappet adjusting screw, Fig. 21, turn the screw up or down until the proper clearance is obtained.

NOTE: On K181QS engines, grind the valve stems to adjust the clearance.

Checking Valve Lift

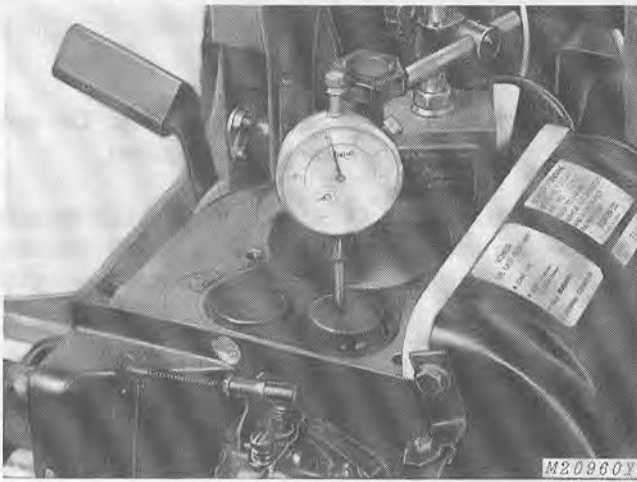

Fig. 22-Checking Valve Lift

Install a dial indicator as shown in Fig. 22. Be sure valve being checked is fully closed when adjusting indicator to zero.

Rotate the crankshaft and observe the maximum valve lift on the dial indicator.

Position the dial indicator on the other valve and repeat rotation of the crankshaft observing the maximum valve lift.

Valve lift for each valve should be 0.250 inch (6.350 mm) or more. If lift is less for either valve, the camshaft lobe is worn and the camshaft must be replaced.

INSTALLATION

Installing Valves

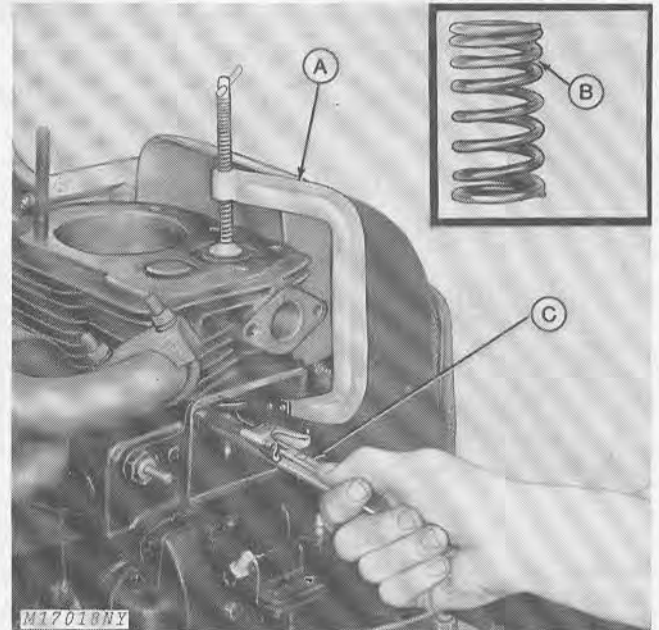

A—Valve Spring Compressor
B—Tight Coils

C—Valve Keeper Tool

Fig. 23-Installing Valve Springs, Retainers and Keepers

Place valve springs with upper and lower retainers in valve spring chamber. Install springs with tight coils (B) up, Fig. 23.

NOTE: Exhaust valve has short spring. Install rotor on exhaust valve spring on K241AQS, K301AQS and K321AQS engines.

Lubricate stems and install valves in guides. Using a valve spring compressor (A, Fig. 23) compress the springs and install keepers on valve stem with keeper tool, (C). If tool is not available, apply grease to keepers to hold them on the valve stem and insert them by hand.

Assembling Breather

The breather must be assembled in the correct order as shown in Figs. 24 and 25. Use new gaskets if old gaskets are damaged. Install breather plate so that small hole in bottom of plate is down.

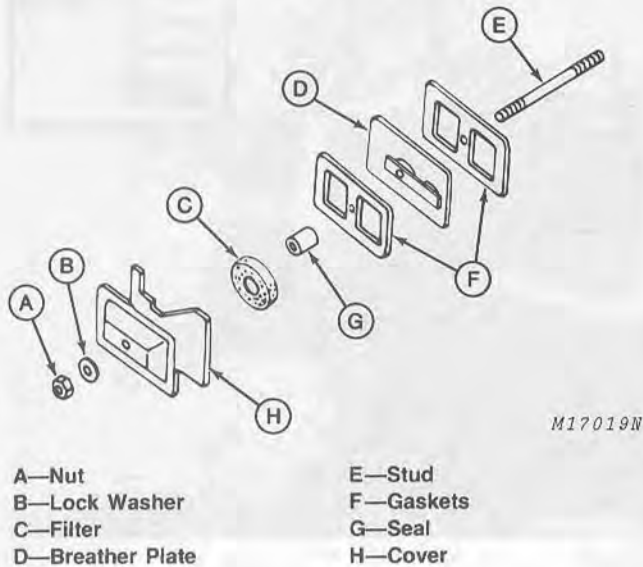

Fig. 24-Breather Parts (200 Tractor)

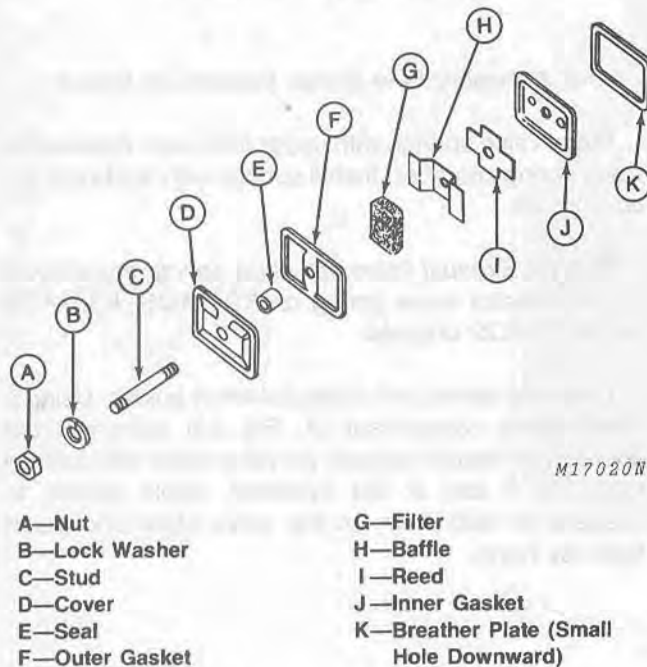

Fig. 25-Breather Parts (210, 212, and 214 Tractors)

Installing Cylinder Head

Always install a new head gasket when head has been removed for service. This will assure a gastight fit.

IMPORTANT: Install head gasket dry. Do not use Permatex or other sealant on gasket.

Clean and apply a light film of oil to head bolt threads to insure an accurate torque reading. Install washers on head bolts with sharp edges down against cylinder head.

It is important to torque all cylinder head bolts evenly and in correct sequence, Figs. 26 and 27, so that uneyen stresses will not be set up in the cylinder wall.

After initial "run-in" period, let engine cool, then retorque head bolts.

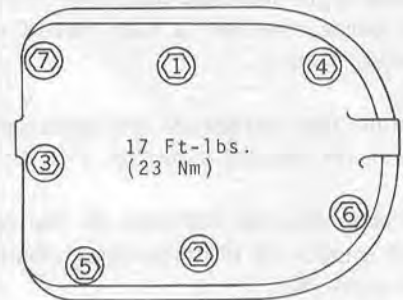

M17021N

Fig. 26-Cylinder Head Bolt Tightening Sequence (200 Tractor)

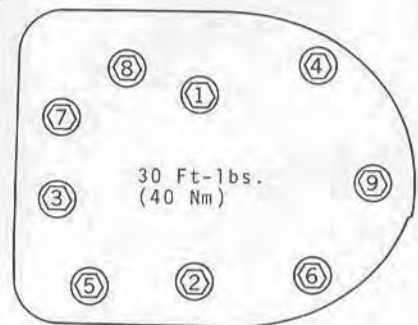

M17022N

Fig. 27-Cylinder Head Bolt Tightening Sequence (210, 212 and 214 Tractors)

Installing Carburetor and Governor Linkage

Refer to Section 30, Group 10 for carburetor and governor linkage installation and adjustments.

Group 15 MINOR ENGINE RECONDITION

GENERAL INFORMATION

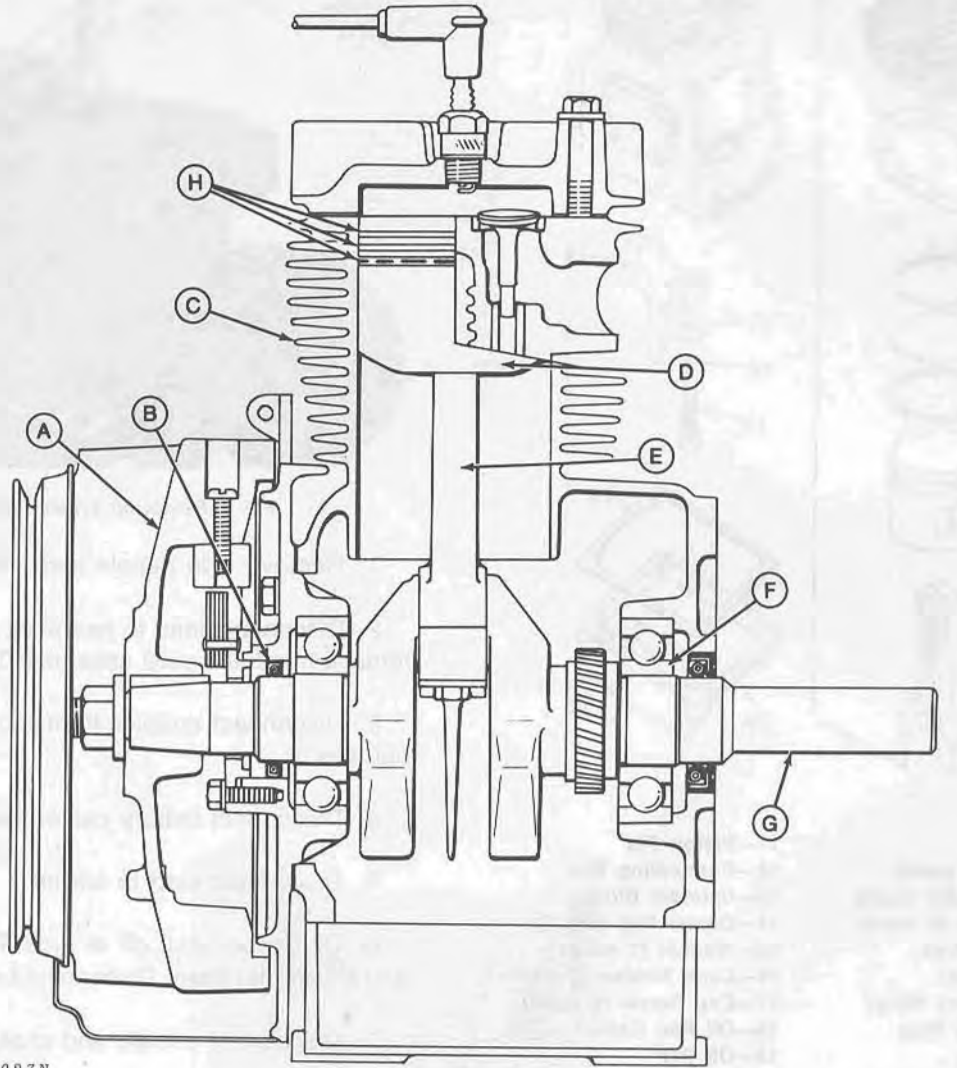

M17023N

A—Flywheel
B—Oil Seal

C—Block
D—Piston

E—Connecting Rod
F—Main Bearing

G—Crankshaft
H—Piston Rings

Fig. 1-Cutaway View of Kohler Engine

Minor engine reconditioning includes piston ring (H), piston (D), piston pin and connecting rod (E) maintenance, Fig. 1. It should also include lapping or grinding valves, cleaning the breather, and valve and governor linkage adjustment.

If inspection reveals that cylinder boring to an oversize is necessary, see Group 20, "Major Engine Recondition."

DISASSEMBLY

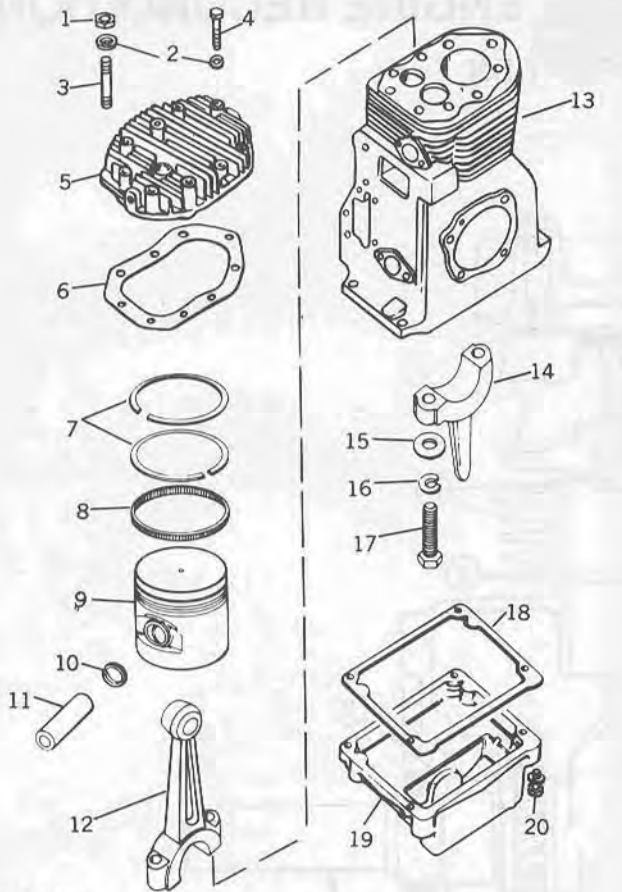

M11573N

- | | |
|------------------------|--|
| 1—Nut | 11—Piston Pin |
| 2—Washer (9 used) | 12—Connecting Rod |
| 3—Stud (cylinder head) | 13—Cylinder Block |
| 4—Cap Screw (8 used) | 14—Connecting Rod Cap |
| 5—Cylinder Head | 15—Washer (2 used) |
| 6—Head Gasket | 16—Lock Washer (2 used) |
| 7—Compression Rings | 17—Cap Screw (2 used) |
| 8—Oil Control Ring | 18—Oil Pan Gasket |
| 9—Piston | 19—Oil Pan |
| 10—Piston Pin Retainer | 20—Cap Screw with Lock Washer (4 used) |

Fig. 2—Exploded View of Kohler Engine Showing Piston and Connecting Rod

Removing Engine

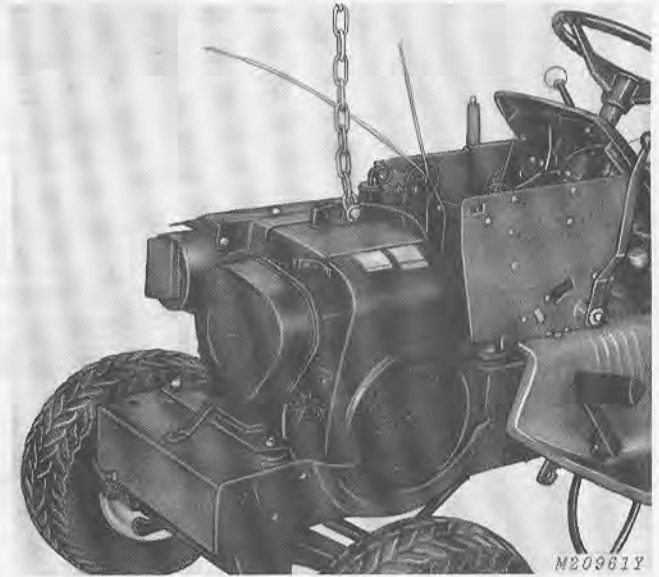

Fig. 3—Removing Engine from Tractor

1. Remove side panels and grille.
2. Disconnect lead to headlight wiring harness and remove hood and cowl assembly. Drain crankcase oil.
3. Disconnect coupler from engine to main wiring harness.
4. Disconnect battery cables (negative cable first).
5. Disconnect lead to starter.
6. Close fuel shut off at tank. Remove air cleaner and air cleaner base. Disconnect fuel line at fuel pump.
7. Disconnect throttle and choke cables.
8. Loosen clutch idler spring, disconnect spring and remove clutch idler.
9. Remove PTO clutch, primary and secondary drive belts.
10. Remove engine base bolts and remove engine.
11. Clean engine prior to disassembly.

Loosen the heat shield from the cylinder head and bend out of way. Remove head baffle, cylinder head, and head gasket. Remove the air intake screen from the blower housing. This allows access to flywheel so engine can be rotated manually.

Removing Cylinder Ridge

As the cylinder wears, a ridge is formed above the ring travel zone. This ridge must be removed before the piston is removed to prevent piston land damage.

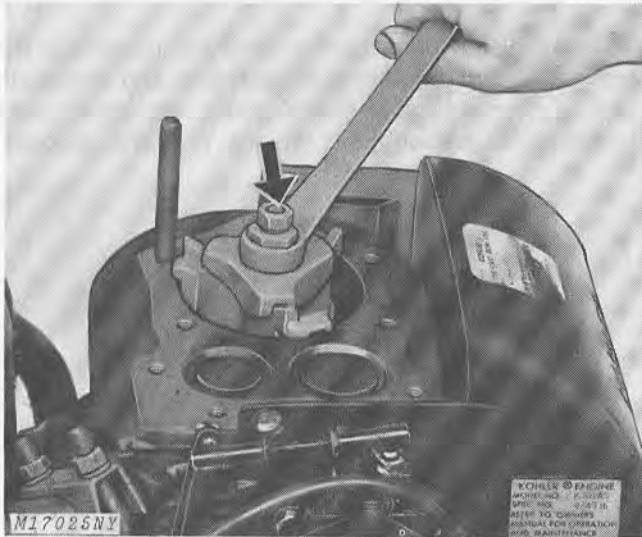

Fig. 4-Removing Cylinder Ridge

Position piston at bottom of its stroke and remove cylinder ridge with a ridge reamer, Fig. 4.

IMPORTANT: Do not cut into the ring travel zone when removing the cylinder ridge.

Removing Piston and Connecting Rod

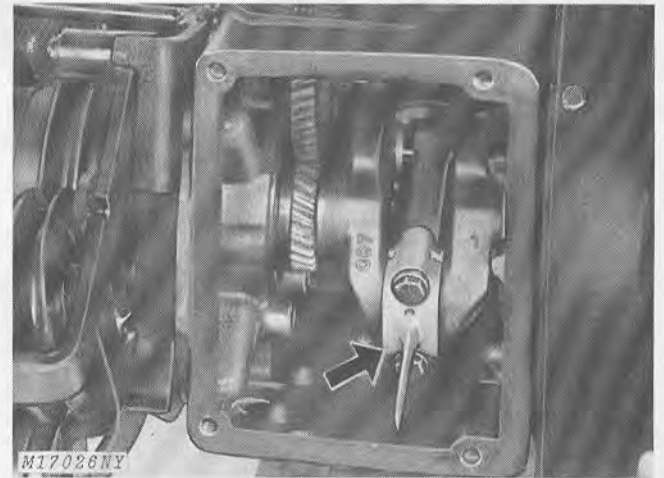
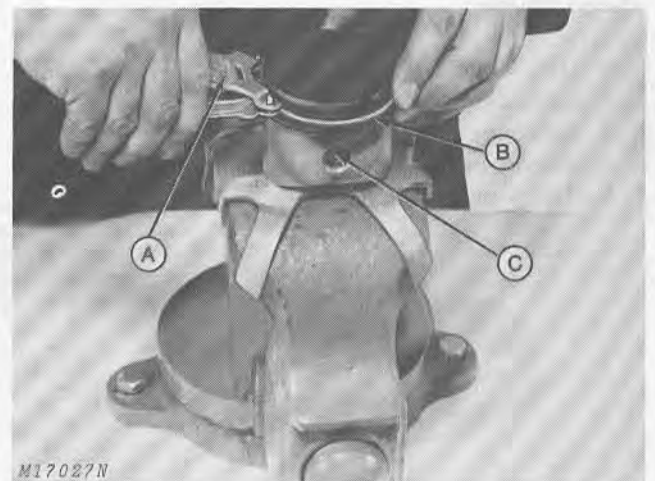

Fig. 5-Removing Connecting Rod Cap

Remove oil pan and gasket.

Remove the two cap screws, Fig. 5, securing the rod cap and remove cap. Carefully push piston and connecting rod out top of block.

Removing Piston Rings and Pin



A—Ring Expander B—Piston Rings C—Retainer

Fig. 6-Removing Piston Rings

Clamp the connecting rod in a soft-jawed vise to prevent damage.

Starting with top ring, remove rings (B) from piston, Fig. 6. Use ring expander (A), if tool is available. Analyze ring condition before discarding.

Remove retainers (C) from each end of piston and push piston pin out with a soft drift.

INSPECTION AND REPAIR

Piston and Piston Rings



Fig. 7-Scored Piston and Rings

Light scuffing or scoring of rings and piston occurs when high friction and combustion temperatures approach the melting point of the piston material, Fig. 7.

If this condition is found, check and correct the following causes:

1. Dirty cooling shroud and cylinder head fins.
2. Lack of cylinder lubrication.
3. Improper combustion.
4. Wrong bearing or piston clearance.
5. Too much oil in crankcase.

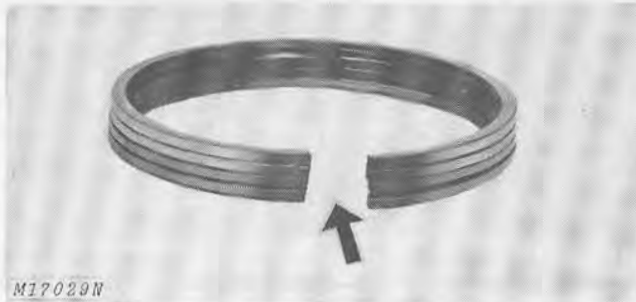
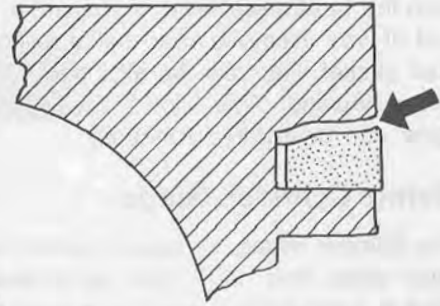

Fig. 8-Piston Rings with Improper End Gap

Wrong size rings or rings having improper end gap, Fig. 8, will not conform to the cylinder. This results in high oil consumption and excessive blowby.

High oil consumption and blowby could also be caused by ring end gaps being in alignment. Ring end gaps should be staggered on the piston during installation.



M17030N

Fig. 9-Top Ring and Groove Side Wear

Check piston ring grooves carefully, especially the top groove, Fig. 9. High temperature and pressure, plus airborne abrasives that enter the combustion chamber, cause wear on the top ring and groove.

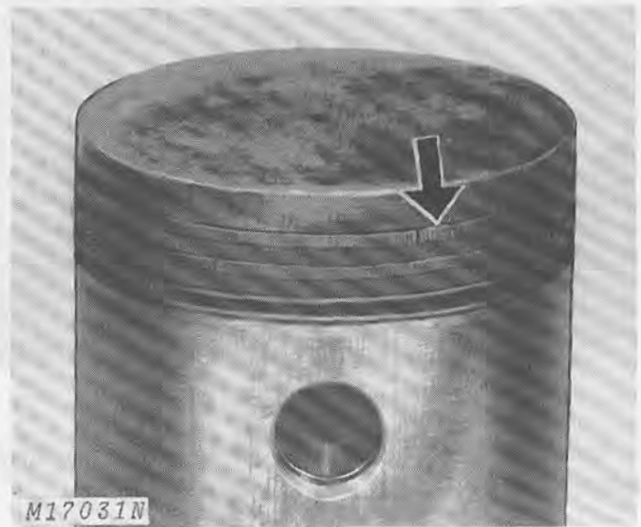

Fig. 10-Piston Rings Stuck and Broken Because of Lacquer, Varnish and Carbon Build-Up

High engine operating temperatures will cause varnish, lacquer or carbon deposits to form in the piston ring grooves causing the rings to stick, Fig. 10. Sticking rings will cause high oil consumption and loss of compression.

Engine heating and sticking rings are caused by:

- | | |
|---------------------------|-------------------|
| 1. Overloading | 5. Incorrect oil |
| 2. Pre-ignition | 6. Low oil supply |
| 3. Incorrect fuel mixture | 7. Stale fuel |
| 4. Dirty cooling fins. | |



Fig. 11-Scratched Ring Faces Caused by Abrasives in the Engine

Vertical scratches across the piston rings, Fig. 11, are caused by abrasives entering the engine. Abrasives may be airborne, loose lead and carbon deposits or particles left in the engine after overhaul.

Common causes for abrasives are:

1. Damaged, collapsed or improperly installed air filter element.
2. Loose connection or damaged gasket between air filter and carburetor.
3. Air leak between carburetor-to-block gasket.
4. Air leak around throttle shaft.
5. Failure to properly clean cylinder bore after reconditioning engine.

In Fig. 12 the rails of the oil ring are worn down to the oil drain holes. This occurs after much use and contact with the cylinder wall and possible entry of abrasives. Compression rings will also be worn thin.

Badly worn oil rings will have an extra large gap and low tension.



Fig. 12-Worn Oil Rings Which Cannot Provide Oil Control

NOTE: Do not use a caustic cleaning solution or a wire brush to clean pistons.

Two methods of cleaning pistons are recommended:

1. Chemical soaking.
2. Glass bead cleaning.

Follow the manufacturer's recommendations for cleaning the pistons.

Check ring grooves for excessive wear by inserting a new ring in the proper groove at several points around the piston.



Fig. 13-Measuring Ring Clearance

Measure clearance between ring and groove with a feeler gauge, Fig. 13. Refer to "Specifications," page 20-25-1, for ring groove clearance.

Piston and Piston Rings—Continued

Replace piston having ring clearance beyond wear limits.

Inspect piston for fractures at the ring lands, skirts and for rough or scored conditions.

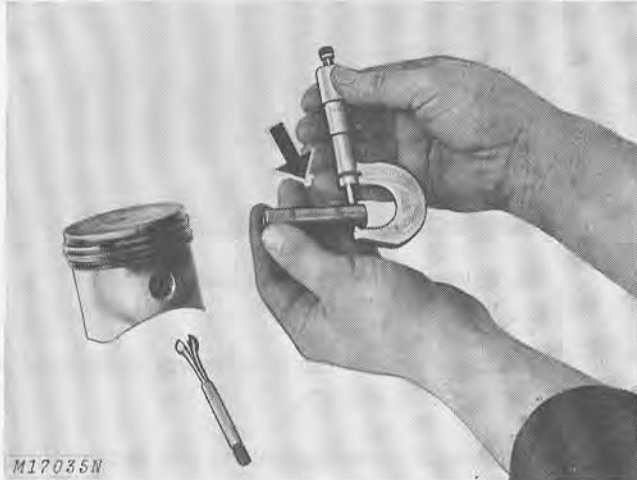

Fig. 14—Measuring Piston Pin and Piston

Measure piston pin-to-piston clearance with a micrometer, Fig. 14. Oversize piston pins are available for service. Ream out piston and rod and install oversize piston pins when necessary. See "Specifications," page 20-25-1.



Fig. 15—Measuring Piston

Check piston-to-cylinder bore clearance by measuring the piston O.D., Fig. 15, and cylinder bore I.D.

To check for piston wear, measure the diameter of the piston skirt across the thrust faces (at right angles to the piston pin bore). Take a reading at both the top and bottom of the skirt.

If piston-to-cylinder bore clearance is 0.005-inch (0.127 mm) or less, deglaze the cylinder wall and install a set of new rings.

If cylinder-to-bore clearance is more than 0.005-inch (0.127 mm), the cylinder will have to be rebored and oversize piston and rings installed.

Oversize pistons and rings are available in 0.010-inch (0.254 mm), 0.020-inch (0.508 mm) and 0.030-inch (0.762 mm) sizes for service.

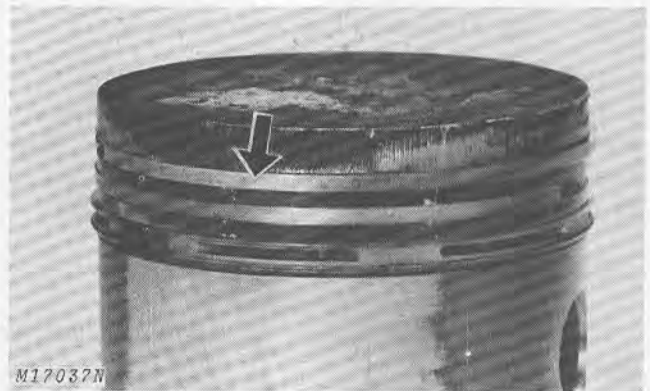

Fig. 16—Piston Top Land Burning Caused by Detonation

Detonation, Fig. 16, or "knocking" occurs when combustion of fuel in the cylinder is too early, too rapid or uneven. The result is a "knock" which can burn the piston, wear out the top groove or cause the ring to break or stick.

Causes of detonation (knock) are:

1. Lean fuel mixtures.
2. Fuel octane too low.
3. Ignition timing advanced too much.
4. Lugging the engine or overfueling.
5. Engine shroud and cooling fins plugged so engine cannot cool properly.



Fig. 17-Diagonal Piston Wear Pattern Caused by Bent or Twisted Connecting Rod

If piston shows a diagonal wear pattern across the skirt of the piston, Fig. 17, check rod and piston alignment.

A cylinder bored at an angle to the crankshaft could also cause a diagonal wear pattern.

The above conditions will cause:

1. Rapid piston wear.
2. Uneven piston wear.
3. Excessive oil consumption.

Pre-ignition is igniting of the fuel-air mixture prior to the regular ignition spark.

As a result, part of the fuel burns while the piston is still coming up on the compression stroke. The burning fuel is compressed and overheated by the piston and by further combustion. The heat can get so high that severe damage to the piston, Fig. 18, rings and valves will occur.

Causes of pre-ignition are:

1. Carbon deposits that remain incandescent and ignite fuel early.
2. Valve operating too hot because of excessive guide clearance or bad seats.
3. Hot spots caused by damaged rings.
4. Spark plug of wrong heat range.
5. Spark plug loose (means "hotter" plug).



Fig. 18-Hole Burned in Piston Caused by Pre-Ignition

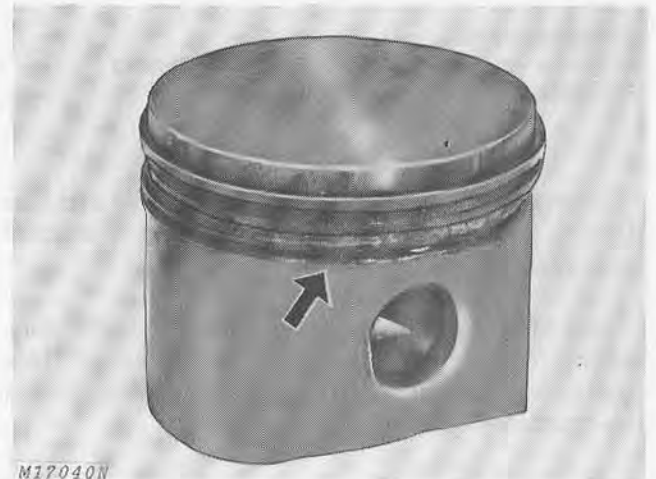

Fig. 19-Piston Damage Caused by Piston Pin Retainer Coming Loose

Piston damaged, Fig. 19, caused by piston pin retainer coming loose or breaking.

Piston pin retainers come loose or break due to:

1. Rod misalignment.
2. Excessive crankshaft end play.
3. Crankshaft journal has too much taper.
4. Cylinder bore out of alignment.
5. Piston pin retainers installed wrong.
6. Piston pin retainers faulty.
7. Piston handled carelessly or dropped.

Inspecting Connecting Rod and Cap

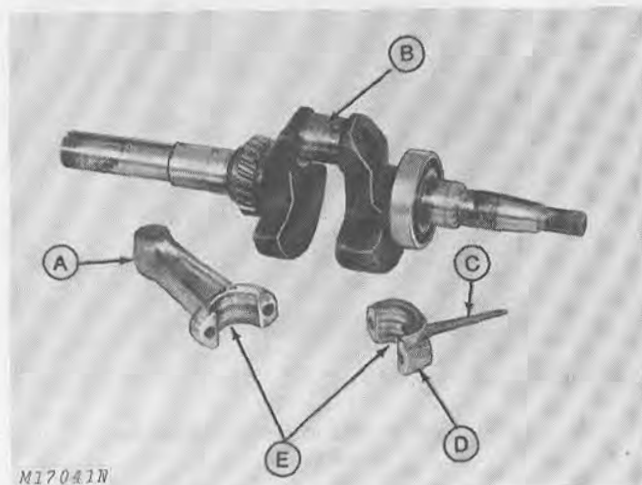

A—Connecting Rod
B—Scored Journal
C—Slinger
D—Cap
E—Scored Bearing Surfaces

Fig. 20—Scored Bearing Surfaces

Clean parts and check connecting rod (A) and cap (D), Fig. 20, for signs of bending, cracking or unusual wear patterns.

Lack of or improper lubrication can cause the connecting rod cap (D) to seize to the crankshaft. This may cause rod bearing particles to be imbedded in the crankshaft journal (B).

When the rod seizes to the crankshaft, the rod and piston may both break causing other damage. If rod seizes, inspect block carefully for cracks or damage before rebuilding engine.

Crankshaft and connecting rod damage can result from:

1. Engine run low on oil or without oil.
2. Oil slinger broken off bearing cap.
3. Oil hole in connecting rod plugged.
4. Oil not changed regularly.
5. Bearing cap installed incorrectly.

Evidence of score marks on rod bearing (E) indicates impurities in the oil or engine run low or without oil.

Replace rod (A) showing scratch marks or deep scores in the bearing area.

IMPORTANT: Be sure slinger (C) on rod cap (D) is intact...not cracked, bent or chipped.

Bent rods can be straightened with a rod aligner.

NOTE: New rods (A) and caps (D) are available only as a matched set for service. If either is damaged, both must be replaced.

Inspecting Crankshaft Journal and Connecting Rod Clearance

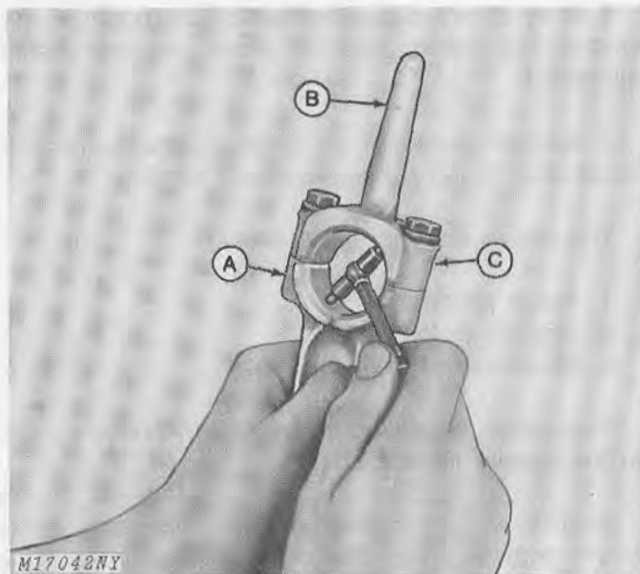

A—Connecting Rod
B—Slinger
C—Cap

Fig. 21—Measuring I.D. of Connecting Rod

Measure fit of rod and cap to crankshaft journal. Install connecting rod cap in place and tighten to the specified torque. Measure the inside diameter of the connecting rod (A) at several places, Fig. 21.

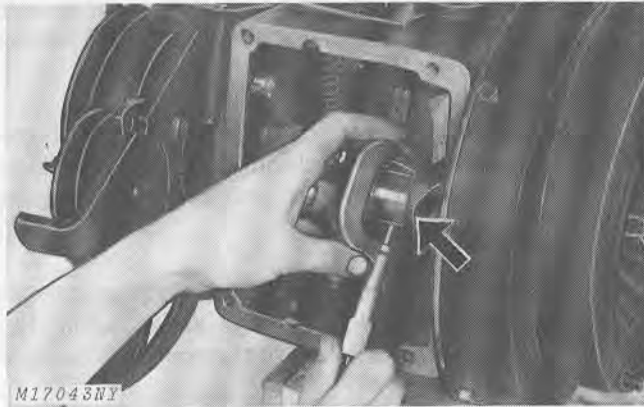

Fig. 22-Measuring Crankshaft

Measure the outside diameter of the crankshaft connecting rod journal, Fig. 22.

Compare the measurements between the connecting rod I.D. and the crankshaft journal O.D. These two measurements will give the proper clearance. See "Specifications," page 20-25-1.

An undersize rod and cap, 0.010-inch (0.254 mm), is available for service.

NOTE: Connecting rod and crankshaft journal must be clean and meet specifications or engine failure will occur.

Inspecting Cylinder

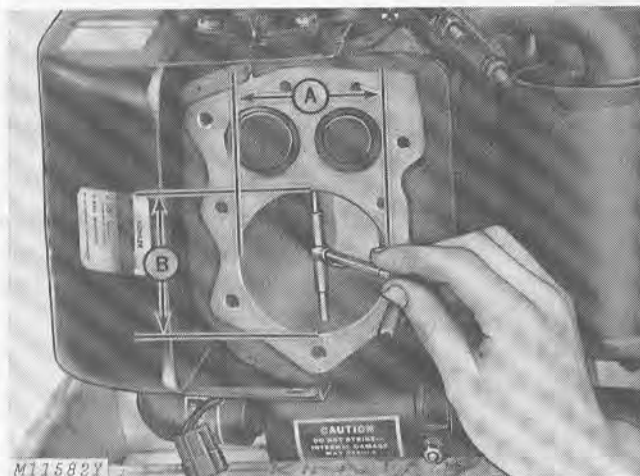

A—Parallel Measurement B—Right-Angle Measurement

Fig. 23-Measuring Cylinder Bore

Using an inside telescoping gauge and micrometer, measure the cylinder bore, Fig. 23, parallel (A) and at right angles (B) to the crankshaft. Measure at both top and bottom of ring travel zone.

If any of the measurements in Fig. 23 exceed "Specifications," reboring is necessary. See Group 20, "Major Engine Recondition" for reboring. If cylinder taper is more than 0.0015 inch (0.0381 mm), reboring is also necessary.

Deglazing Cylinder

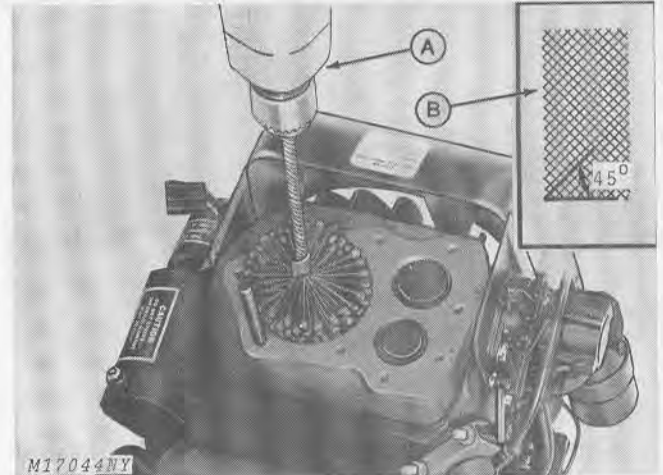

A—Electric Drill

B—Deglazing Hone Pattern

Fig. 24-Deglazing Cylinder Bore

If cylinder is within tolerance and not damaged, lightly deglaze cylinder bore, Fig. 24. Deglazing provides faster, more positive seating of new piston rings, and also helps retain lubrication on cylinder walls during break-in period.

IMPORTANT: Cover crankshaft with rags prior to deglazing to keep small particles out of crankshaft bearings and other internal parts.

Operate the deglazing tool in and out vertically to provide a cross-hatch pattern. See Insert, Fig. 24. Follow tool manufacturer's recommendations.

Carefully clean cylinder bore with soap and water after deglazing. Dry thoroughly and apply a light coat of oil to prevent rust.

ASSEMBLY

Installing Piston Pin

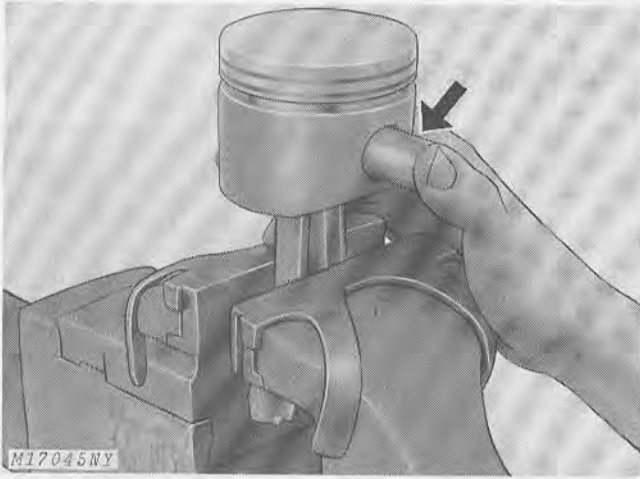
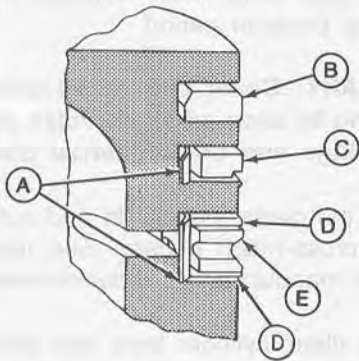

Fig. 25-Installing Piston Pin

Clamp connecting rod in a soft-jawed vise. Liberally coat piston, piston pin and connecting rod with oil.

Push piston pin, Fig. 25, into place and install new retainers. Be certain retainers are properly seated in grooves.

Installing Piston Rings



M17046N

- A—Expanders
- B—Chrome Ring (Bevel Up)
- C—Cast Iron Ring (Scraper Groove Down)
- D—Chrome Steel Rails
- E—Cast Iron Spacer

Fig. 26-Piston Ring Assembly

Use a piston ring expander for ring installation to avoid twisting or stretching rings which could permanently distort rings and reduce performance.

Install oil control ring first, starting with expander (A, Fig. 26). Spiral lower chrome rail (D) into place, install cast iron spacer (E), and then spiral upper chrome rail (D) into place.

Install expander (A) behind lower compression ring (C) and install compression rings as shown in Fig. 26. Stagger end gaps to prevent gaps from being in alignment.

Installing Piston and Connecting Rod

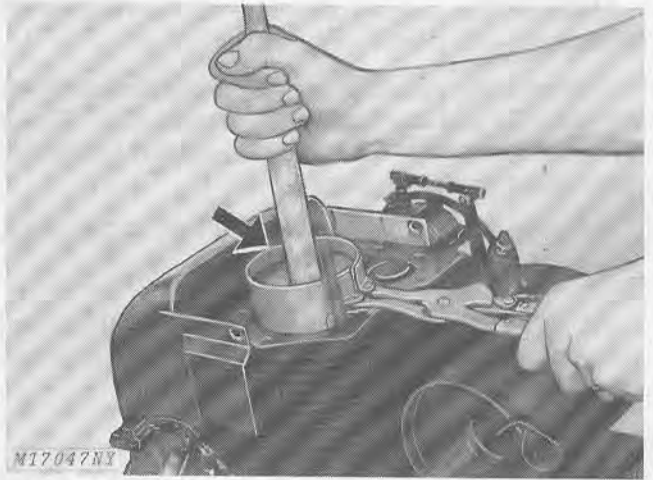

Fig. 27-Installing Piston in Cylinder

Coat piston, rings, and crankshaft journal with oil. Install piston into cylinder with match mark on connecting rod facing flywheel side of engine.

Compress rings with a ring compressor (See "Special Tools," Section 80) and gently push piston down with hammer handle, Fig. 27, until connecting rod is in position on crankshaft journal.

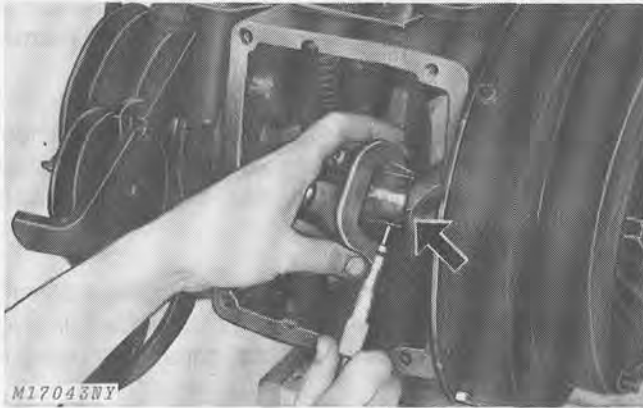

Fig. 22-Measuring Crankshaft

Measure the outside diameter of the crankshaft connecting rod journal, Fig. 22.

Compare the measurements between the connecting rod I.D. and the crankshaft journal O.D. These two measurements will give the proper clearance. See "Specifications," page 20-25-1.

An undersize rod and cap, 0.010-inch (0.254 mm), is available for service.

NOTE: Connecting rod and crankshaft journal must be clean and meet specifications or engine failure will occur.

Inspecting Cylinder

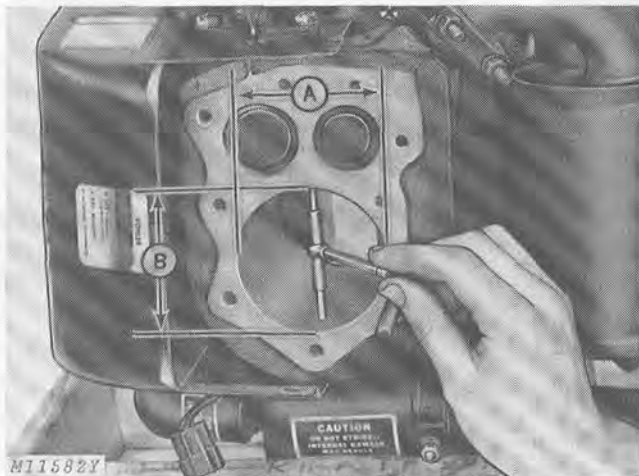

A—Parallel Measurement B—Right-Angle Measurement

Fig. 23-Measuring Cylinder Bore

Using an inside telescoping gauge and micrometer, measure the cylinder bore, Fig. 23, parallel (A) and at right angles (B) to the crankshaft. Measure at both top and bottom of ring travel zone.

If any of the measurements in Fig. 23 exceed "Specifications," reboring is necessary. See Group 20, "Major Engine Recondition" for reboring. If cylinder taper is more than 0.0015 inch (0.0381 mm), reboring is also necessary.

Deglazing Cylinder

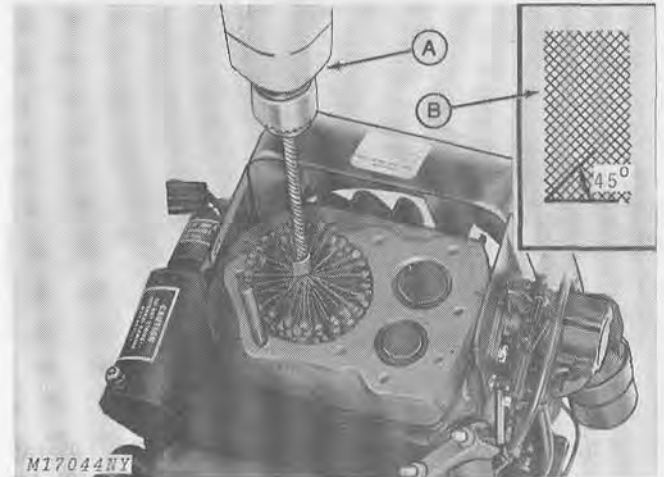

A—Electric Drill

B—Deglazing Hone Pattern

Fig. 24-Deglazing Cylinder Bore

If cylinder is within tolerance and not damaged, lightly deglaze cylinder bore, Fig. 24. Deglazing provides faster, more positive seating of new piston rings, and also helps retain lubrication on cylinder walls during break-in period.

IMPORTANT: Cover crankshaft with rags prior to deglazing to keep small particles out of crankshaft bearings and other internal parts.

Operate the deglazing tool in and out vertically to provide a cross-hatch pattern. See Insert, Fig. 24. Follow tool manufacturer's recommendations.

Carefully clean cylinder bore with soap and water after deglazing. Dry thoroughly and apply a light coat of oil to prevent rust.

ASSEMBLY

Installing Piston Pin

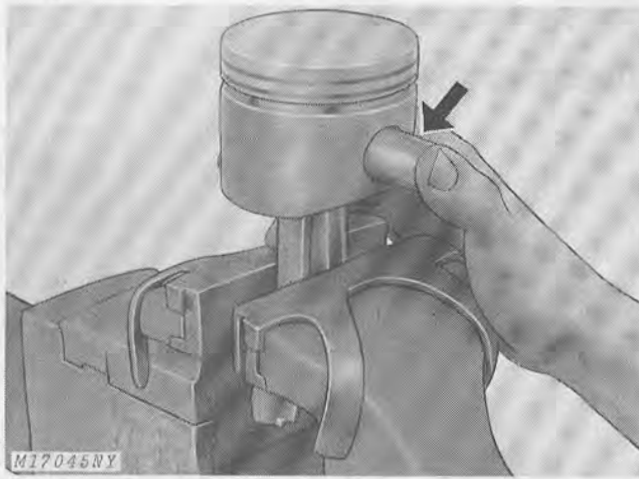
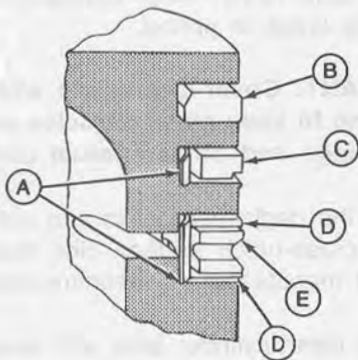

Fig. 25-Installing Piston Pin

Clamp connecting rod in a soft-jawed vise. Liberal-ly coat piston, piston pin and connecting rod with oil.

Push piston pin, Fig. 25, into place and install new retainers. Be certain retainers are properly seated in grooves.

Installing Piston Rings



- A—Expanders
- B—Chrome Ring (Bevel Up)
- C—Cast Iron Ring (Scraper Groove Down)
- D—Chrome Steel Rails
- E—Cast Iron Spacer

Fig. 26-Piston Ring Assembly

Use a piston ring expander for ring installation to avoid twisting or stretching rings which could permanently distort rings and reduce performance.

Install oil control ring first, starting with expander (A, Fig. 26). Spiral lower chrome rail (D) into place, install cast iron spacer (E), and then spiral upper chrome rail (D) into place.

Install expander (A) behind lower compression ring (C) and install compression rings as shown in Fig. 26. Stagger end gaps to prevent gaps from being in alignment.

Installing Piston and Connecting Rod

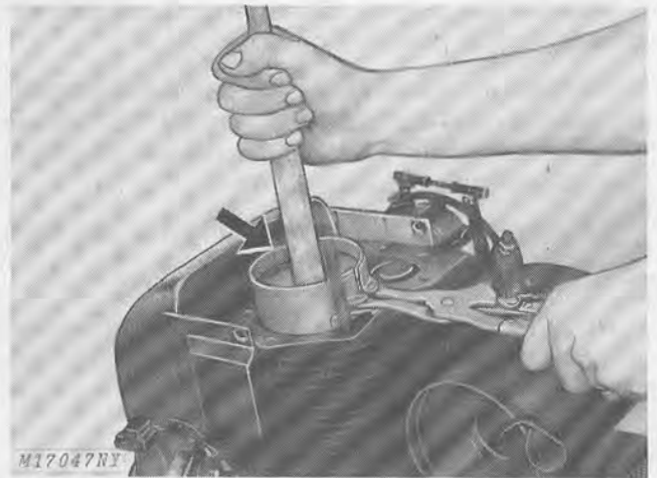
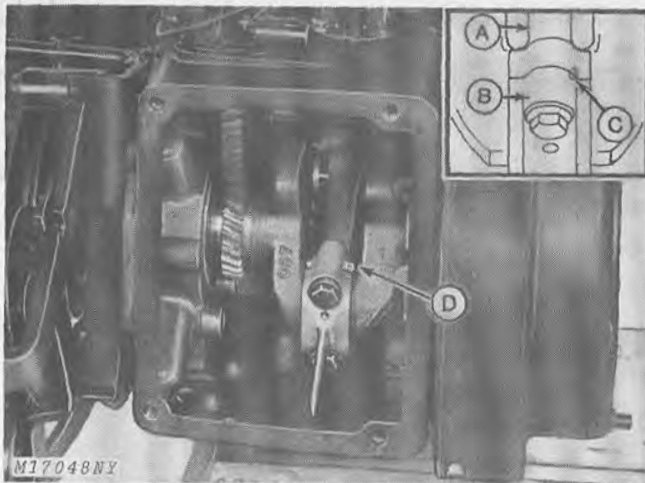

Fig. 27-Installing Piston in Cylinder

Coat piston, rings, and crankshaft journal with oil. Install piston into cylinder with match mark on connecting rod facing flywheel side of engine.

Compress rings with a ring compressor (See "Special Tools," Section 80) and gently push piston down with hammer handle, Fig. 27, until connecting rod is in position on crankshaft journal.



A—Rod
B—Cap
C—Match Marks
D—Match Marks Toward Flywheel

Fig. 28-Installing Rod Cap

Coat rod cap (B, Fig. 28) with oil and install so that match marks (C) align and face flywheel side of engine (D). Lubricate and install cap screws, lock washers and flat washers (sharp edge toward rod cap). Torque cap screws evenly to 25 ft-lbs (33.9 Nm).

Installing Oil Pan

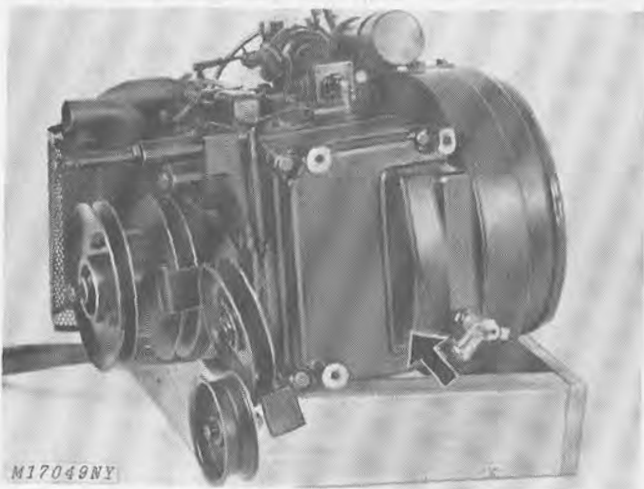

Fig. 29-Installing Oil Pan

Install oil pan, Fig. 29, using new gasket. Sump must be on flywheel side. Tighten cap screws evenly.

Installing Cylinder Head

Always install a new head gasket when head has been removed for service. This will assure a gas-tight fit.

IMPORTANT: Install head gasket dry. Do not use Permatex or other sealant on gasket.

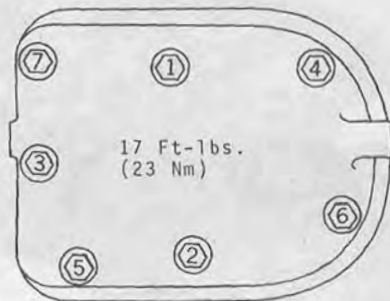

Fig. 30-Cylinder Head Torquing Sequence for 200 Tractor

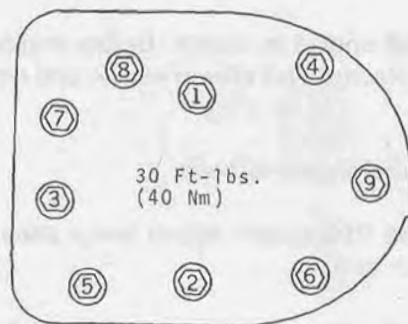

Fig. 31-Cylinder Head Torquing Sequence for 210, 212 and 214 Tractors

Clean and apply a light film of oil to head bolt threads to insure an accurate torque reading. Install washers on head bolts with sharp edges down against cylinder head.

It is important to torque all cylinder head bolts evenly and in the correct sequence, Figs. 30 and 31, so that uneven stresses will not be set up in the cylinder wall. Torque head bolts to 17 ft-lbs (23 Nm) on 200 Tractors and 30 ft-lbs (40.6 Nm) on 210, 212 and 214 Tractors.

Installing Engine in Tractor

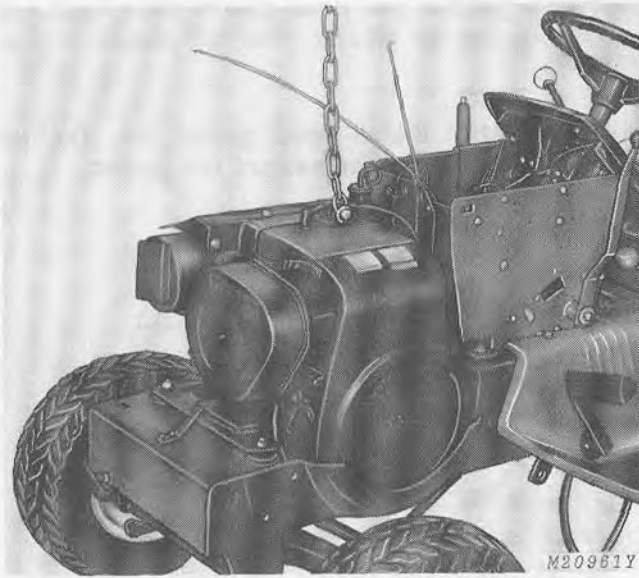

Fig. 32-Installing Engine in Tractor

1. Install engine in tractor. Before engine is completely in place, install idler to engine and replace idler spring.
2. Secure engine to base.
3. Install PTO clutch. Adjust brake shoe and connect clutch arm.
4. Install primary and secondary drive belts.

5. Install choke and throttle cables to carburetor.
6. Install fuel line, air filter base and air filter. Open fuel shut-off at tank.
7. Connect coupler between main wiring harness and engine.
8. Install battery cables (positive cable first).
9. Install hood and cowl assembly, grill and side panels.
10. Replace crankcase oil.

RUN-IN PROCEDURE

IMPORTANT: After recondition, engine must be "run-in" on non-detergent type oil and under load for a period of 5 hours. This allows sufficient time to seat the piston rings.

After the 5-hour "run-in" period, drain the non-detergent oil and fill crankcase with oil of type specified in Section 10, Group 15.

DO NOT use non-detergent oil after the 5-hour "run-in" period.

Let engine cool, then retorque cylinder head bolts.

Group 20 MAJOR ENGINE RECONDITION

GENERAL INFORMATION

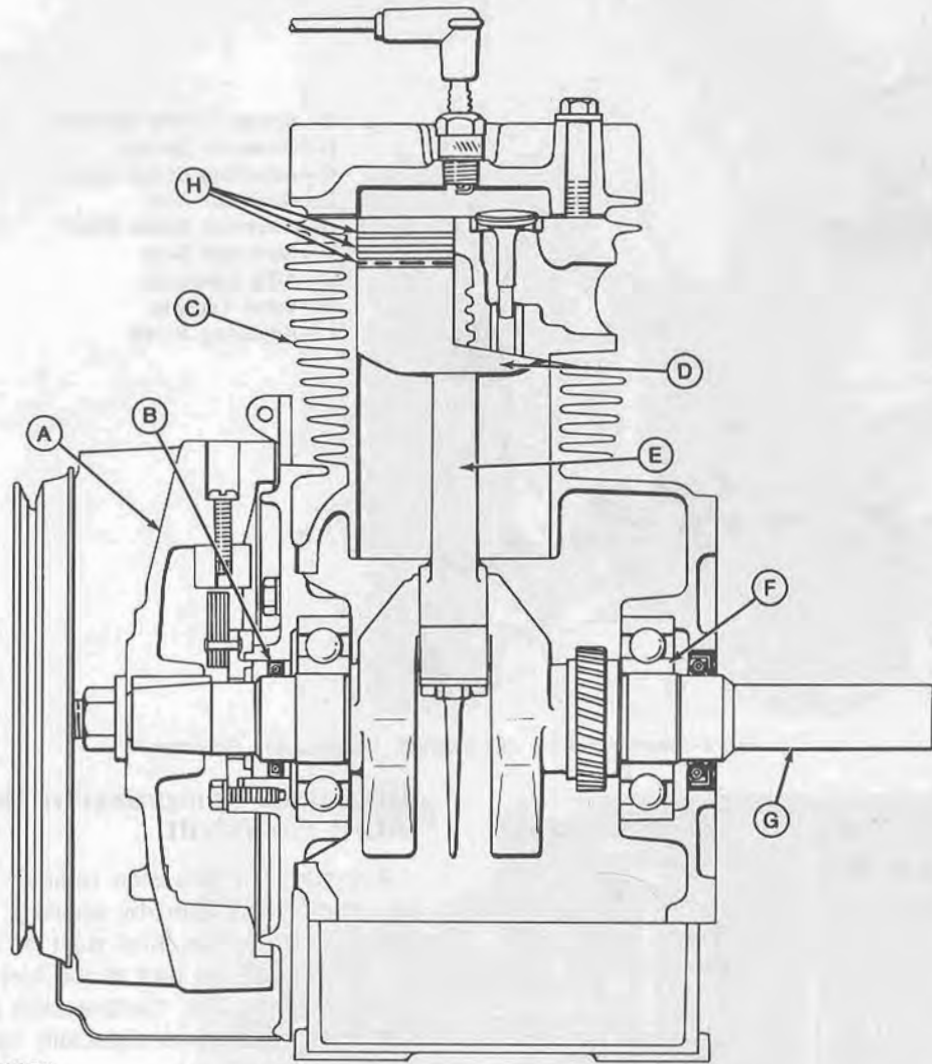

M17023N

A—Flywheel
B—Oil Seal

C—Block
D—Piston

E—Connecting Rod
F—Main Bearing

G—Crankshaft
H—Piston Rings

Fig. 1—Cutaway View of Kohler Engine

Major engine reconditioning includes piston, connecting rod, crankshaft, camshaft, tappet and governor maintenance.

The Kohler engines, Fig. 1, feature an automatic compression release camshaft. See page 20-20-2.

Pistons and rings are available in 0.010 (0.254 mm), 0.020 (0.508 mm) and 0.030 (0.762 mm)-inch oversizes to accommodate rebored cylinders. A 0.010 (0.254 mm)-inch undersize connecting rod is available if crankshaft journal grinding is necessary.

Valve grinding or lapping, breather maintenance, and governor linkage adjustment should also be performed.

GENERAL INFORMATION—Continued

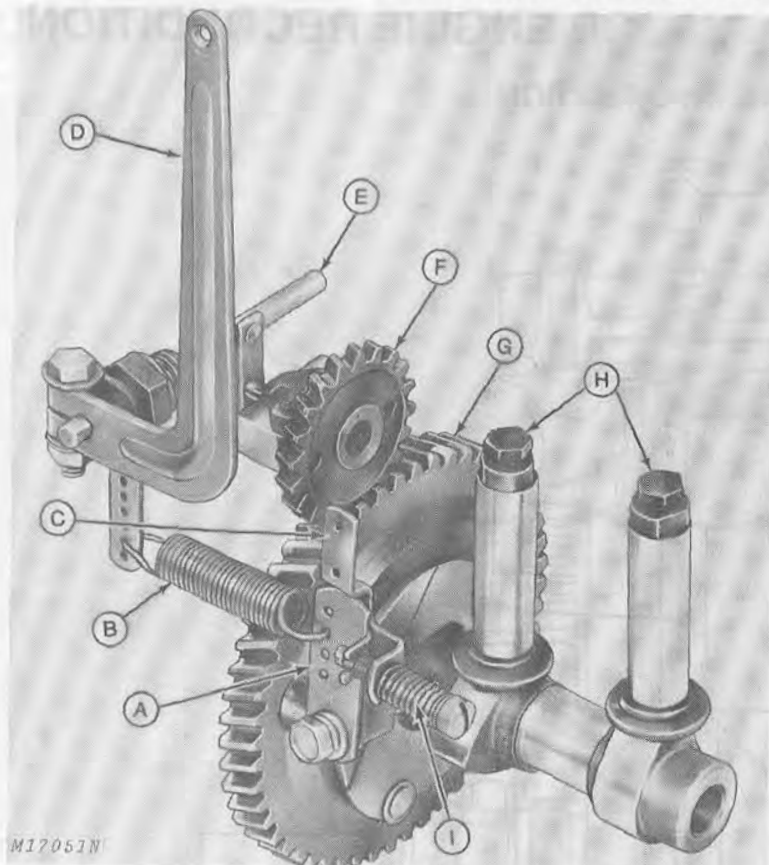

- A—Speed Control Bracket
- B—Governor Spring
- C—Adjusting Screw Lever
- D—Governor Arm
- E—Governor Cross Shaft
- F—Governor Gear
- G—ACR Camshaft
- H—Valve Tappets
- I—Adjusting Screw

Fig. 2—Assembled View of Camshaft, Tappets, and Governor

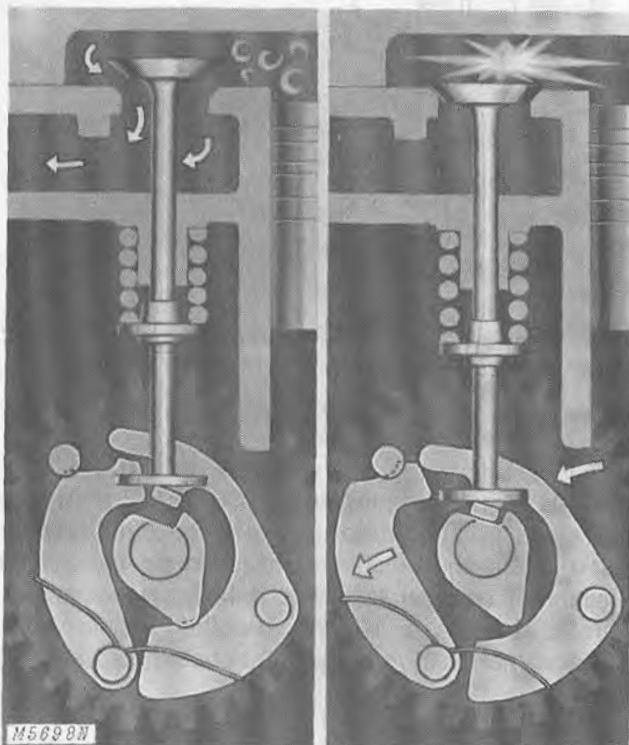

Fig. 3—ACR Operation

Automatic Compression Release (ACR) Camshaft

Automatic compression release provides a reduction in cranking effort by opening the exhaust valve slightly during the first part of the compression stroke. This allows part of the fuel-air mixture to escape, lowering the compression pressure, Figs. 2 and 3. This feature is especially valuable during cold weather starting.

By releasing compression, the pressure of the burning mixture is reduced sufficiently for the flywheel to carry the engine over top dead center. This prevents "kick-back" and eliminates the need for a spark retard mechanism.

When the engine speed reaches approximately 650 rpm, centrifugal force disengages the automatic compression release allowing the engine to operate in the usual manner at all higher speeds, with no loss of power.

DISASSEMBLY

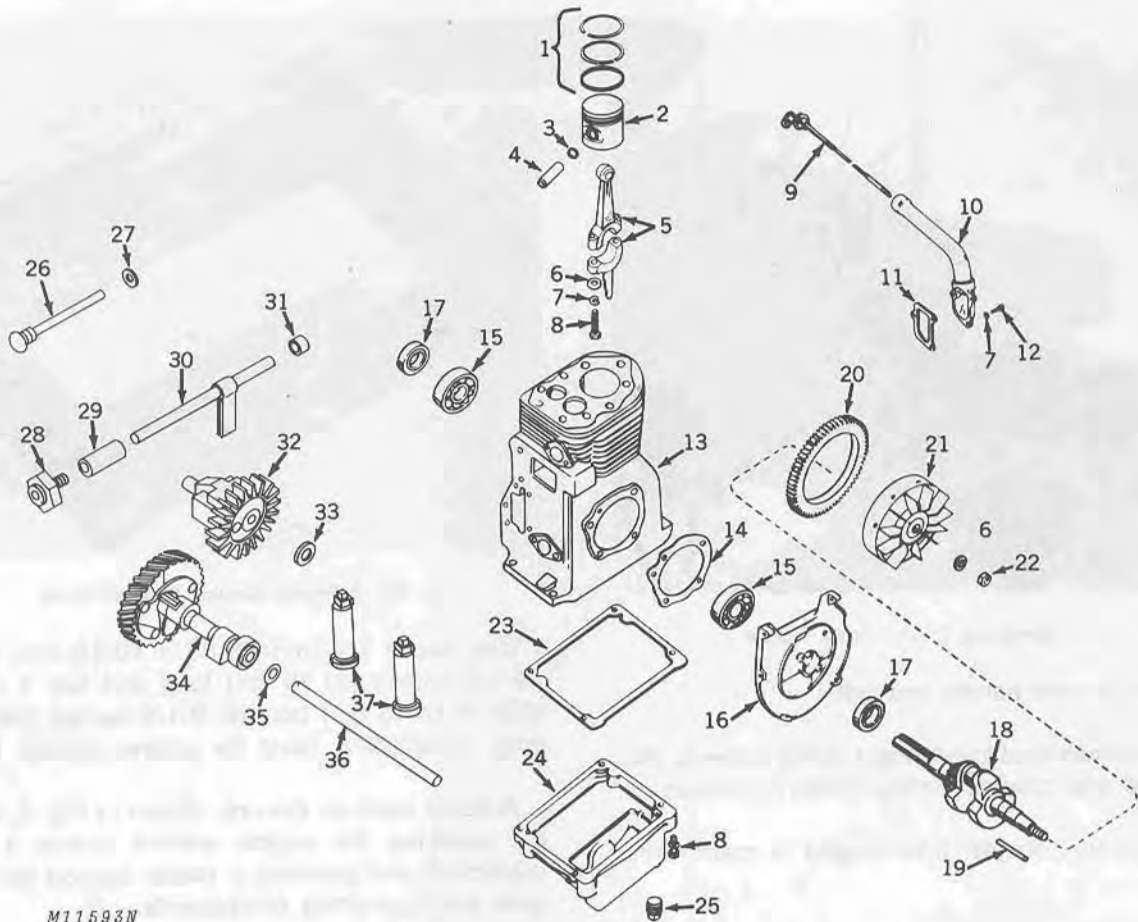

M11593N

- | | | |
|--------------------------------|--------------------------|--|
| 1—Ring Set | 14—Bearing Plate Gasket | 26—Governor Stop Pin |
| 2—Piston | 15—Ball Bearing (2 used) | 27—Stop Pin Washer |
| 3—Piston Pin Retainer (2 used) | 16—Bearing Plate | 28—Governor Bushing |
| 4—Piston Pin | 17—Oil Seal (2 used) | 29—Spacer |
| 5—Connecting Rod | 18—Crankshaft | 30—Governor Cross Shaft |
| 6—Washer | 19—Key | 31—Cross Shaft Bearing |
| 7—Lock Washer | 20—Ring Gear | 32—Governor Gear |
| 8—Cap Screw | 21—Flywheel | 33—Thrust Washer |
| 9—Dipstick | 22—Lock Nut | 34—ACR Camshaft |
| 10—Oil Fill Tube | 23—Oil Pan Gasket | 35—Spacing Washer (0.005
or 0.010 inch as required) |
| 11—Fill Tube Gasket | 24—Oil Pan | 36—Camshaft Pin |
| 12—Machine Screw (3 used) | 25—Drain Plug | 37—Tappets (2 used) |
| 13—Cylinder Block | | |

Fig. 4-Exploded View of Kohler Engine

Removing Engine

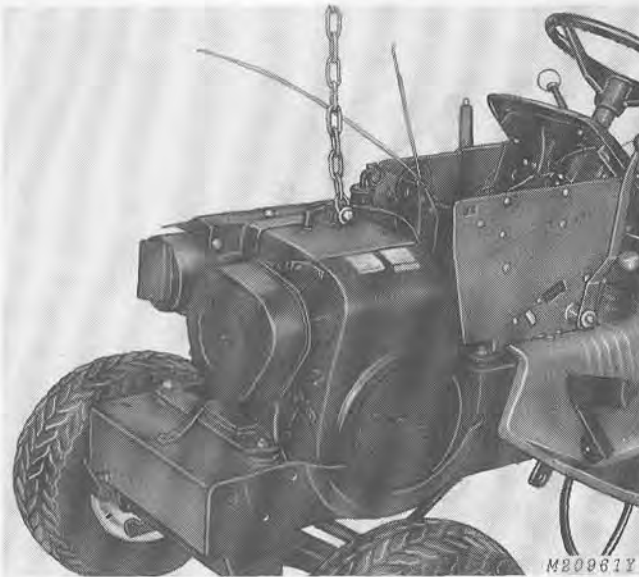

Fig. 5-Removing Engine From Tractor

1. Remove side panels and grill.
2. Disconnect lead to headlight wiring harness. Remove hood and cowl assembly. Drain crankcase oil.
3. Disconnect coupler from engine to main wiring harness.
4. Disconnect battery cables (negative cable first).
5. Disconnect lead to starter.
6. Close fuel shut-off at tank. Remove air cleaner and air cleaner base. Disconnect fuel line at fuel pump.
7. Disconnect throttle and choke cables.
8. Loosen clutch idler spring, disconnect spring and remove clutch idler.
9. Remove PTO clutch. Remove primary and secondary drive belts.
10. Remove engine base bolts and remove engine.
11. Clean engine prior to disassembly.

Engine Support Stand

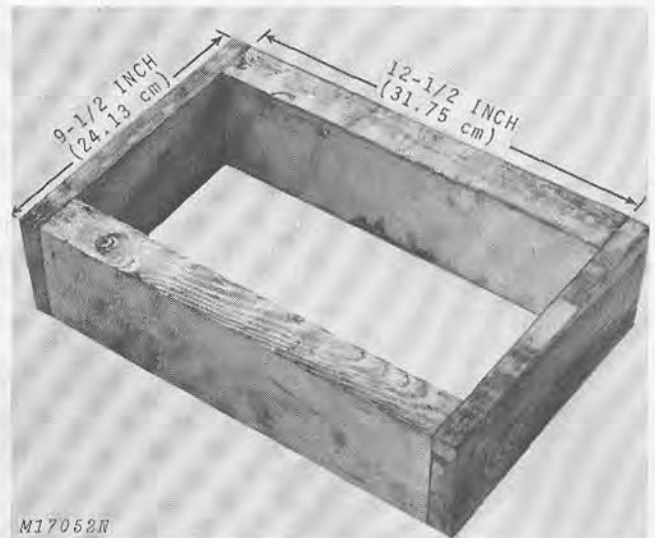

Fig. 6-Engine Service Support Stand

Use two 2 x 4-inch (5.05 x 10.16 cm) boards, 12-1/2 inches (31.75 cm) long and two 1 x 4-inch (2.54 x 10.16 cm) boards, 9-1/2 inches (24.13 cm) long, construct a stand for engine service, Fig. 6.

A stand such as the one shown in Fig. 6, will permit servicing the engine without resting it on the crankshaft and provides a stable support for the engine while servicing components.

Minor Engine Reconditioning

Many engines require only minor reconditioning which includes piston rings, piston, piston pin, or connecting rod replacement.

If minor reconditioning is to be performed, complete engine teardown is not necessary. See Group 15 of this section.

Short Block Installation

If major reconditioning is not practical, install a short block.

Removing Exterior Components

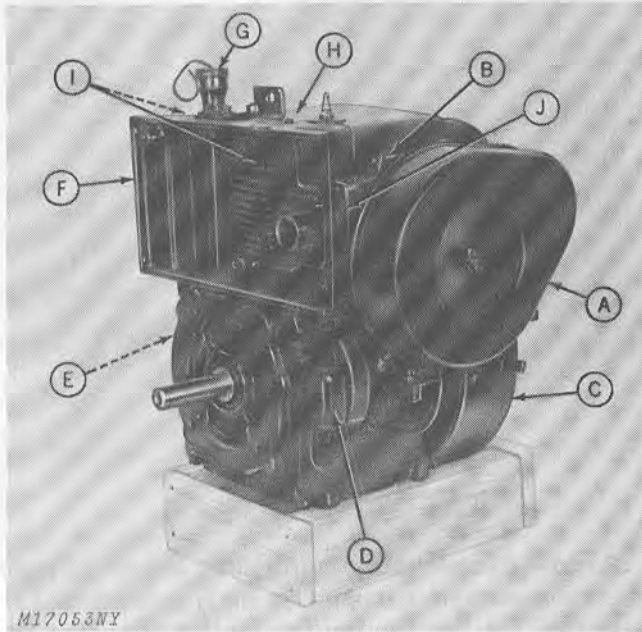

- A—Air Cleaner and Carburetor
- B—Governor Linkage and Breather Assembly
- C—Blower Housing
- D—Breaker Cover and Points
- E—Starter Motor
- F—Air Duct
- G—Oil Fill Tube
- H—Head Baffle
- I—Cylinder Baffle and Cylinder Head
- J—Air Side Baffle

Fig. 7-Removing Exterior Components

Remove the parts listed in Fig. 7.

Removing Valves

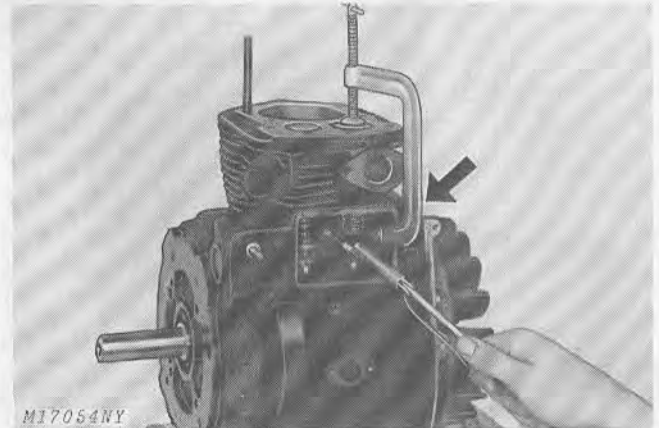

Fig. 8-Removing Valve Keepers

Compress the valve springs using a valve spring compressor tool, Fig. 8, and remove the keepers. Lift valves out of engine block. Remove valve spring retainers, rotator, and springs from the valve chamber.

See Group 10 of this section for valve maintenance.

Removing Cylinder Ridge

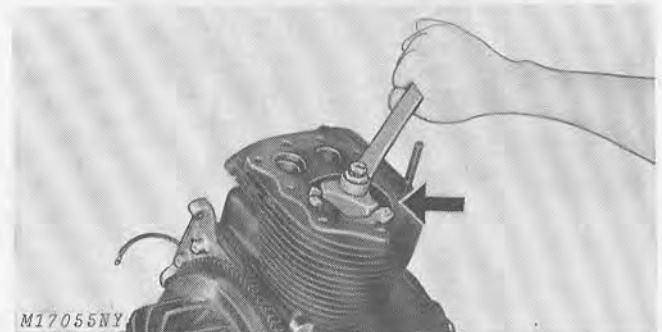

Fig. 9-Removing Cylinder Ridge

As the cylinder wears, a ridge is formed above the ring travel zone. This ridge must be removed before the piston is removed to prevent piston land damage.

Position piston at bottom of its stroke and remove cylinder ridge with a ridge reamer, Fig. 9. See "Special Tools" in Section 80.

IMPORTANT: Do not cut into the ring travel zone when removing the cylinder ridge.

Removing Piston and Connecting Rod

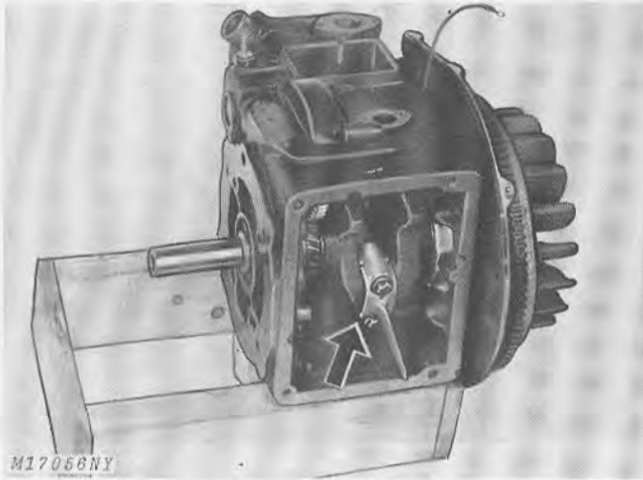

Fig. 10-Removing Connecting Rod Cap

Remove oil pan and gasket.

Remove the cap screws, Fig. 10, securing the rod cap and remove cap. Carefully push piston and connecting rod out top of block.

Removing Piston Rings and Pin

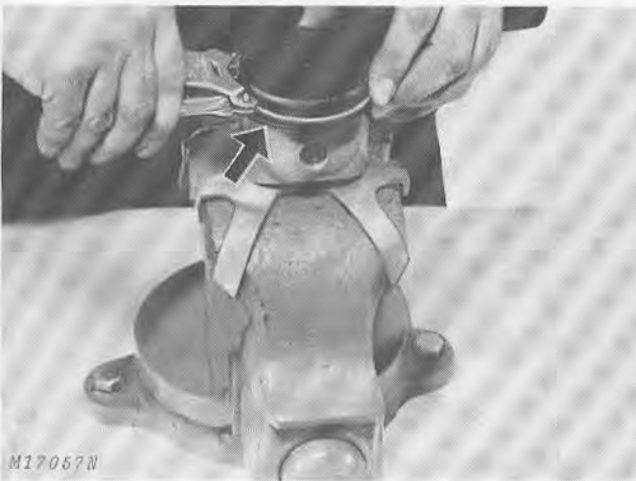

Fig. 11-Removing Piston Rings

Clamp the connecting rod in a soft-jawed vise to prevent damage.

Starting with top ring, Fig. 11, remove rings from piston. Use ring expander if tool is available. Analyze rings before discarding. See page 20-15-4.

Remove retainers from each end of piston and push piston pin out with a soft drift.

Removing Flywheel

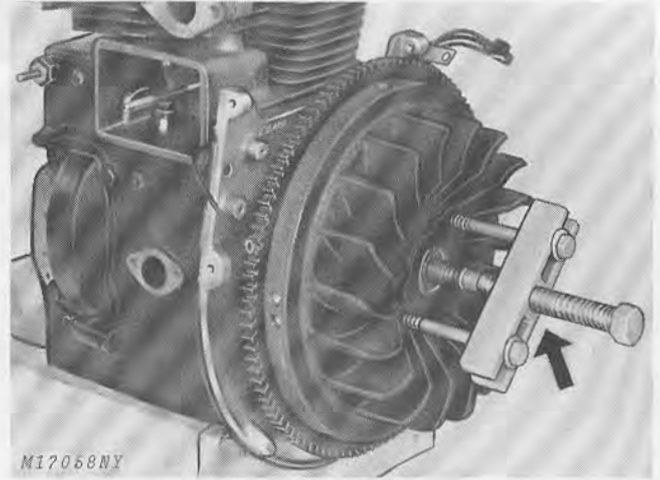

Fig. 12-Removing Flywheel

Remove flywheel nut using a strap wrench to prevent flywheel from turning. Use an H-puller, Fig. 12, with two 3/8-inch bolts to remove flywheel. See "Special Tools" in Section 80.

Remove flywheel key from crankshaft.

Removing Bearing Plate

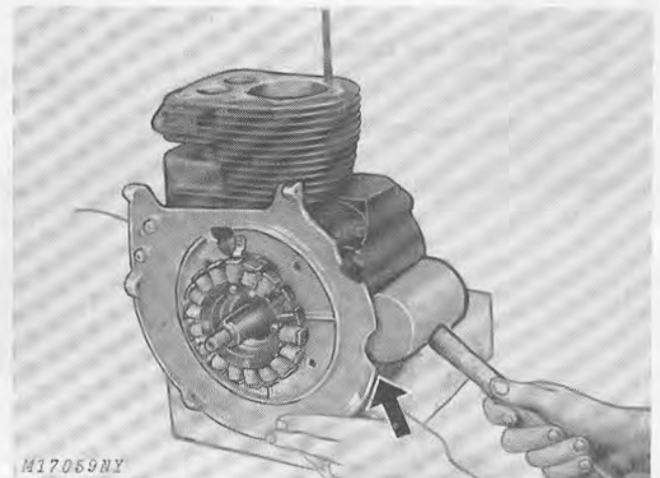

Fig. 13-Removing Bearing Plate

Remove cap screws securing bearing plate to cylinder block. Carefully tap bearing plate off crankshaft, using a soft mallet, Fig. 13.

IMPORTANT: Tap carefully, moving from side to side to prevent damage to bearing plate.

Remove gaskets from behind bearing plate.

Removing Crankshaft

Press crankshaft out flywheel side of engine.

Removing Camshaft

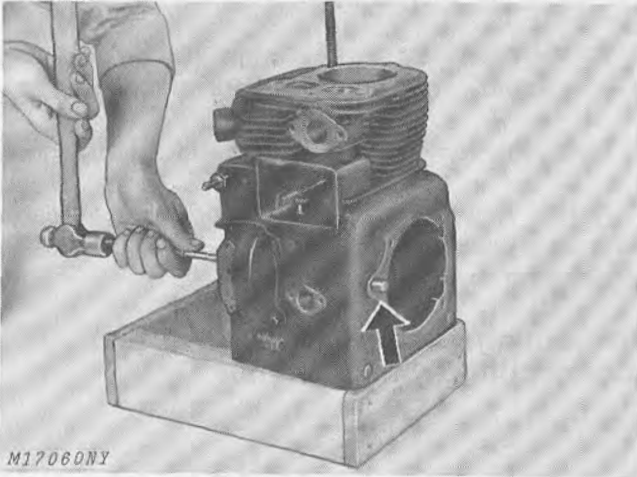

Fig. 14-Removing Camshaft Pin

Use a drift punch and drive camshaft pin, Fig. 14, out flywheel side of block. Pin will slide out easily after it is driven free from the PTO side of block.

Lift out camshaft.

NOTE: Watch for and save camshaft spacing washer(s) when removing camshaft.

Mark tappets before removing to be sure they are returned to same tappet hole. Lift tappets out.

Removing Governor Assembly

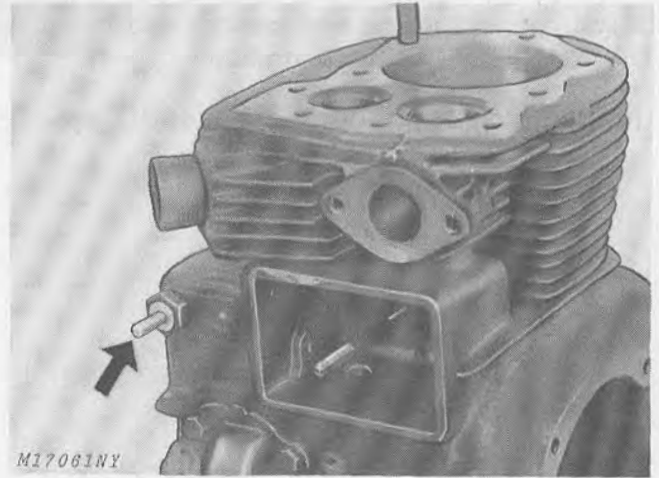

Fig. 15-Removing Cross Shaft Bushing and Stop Pin

Remove cross shaft bushing and governor stop pin, Fig. 15, from cylinder block.

Turn block upside down and remove cross shaft and governor gear assembly from inside.

NOTE: Be careful not to lose thrust washer behind governor gear assembly.

INSPECTION AND REPAIR

NOTE: For inspection and repair of piston, piston rings, connecting rod and rod cap refer to page 20-15-4 "Minor Engine Recondition".

Inspecting Connecting Rod and Cap

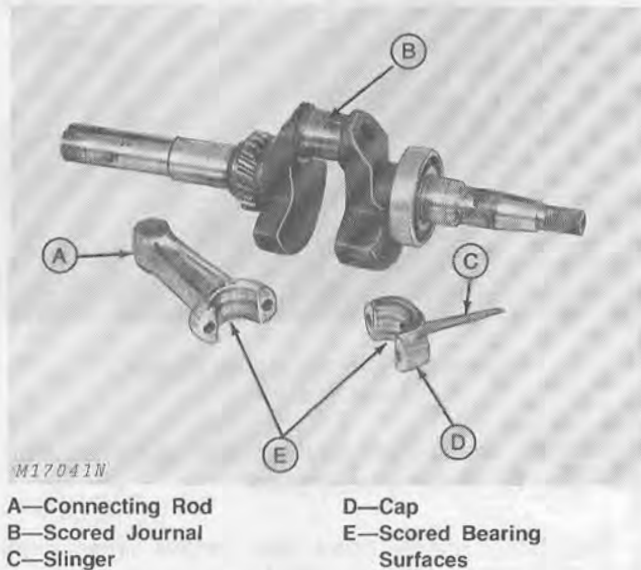

Fig. 16—Scored Bearing Surfaces

Clean parts and check connecting rod (A) and cap (D), Fig. 16, for signs of bending, cracking or unusual wear patterns.

Lack of improper lubrication can cause the connecting rod cap (D) to seize to the crankshaft. This may cause rod bearing particles to be imbedded in the crankshaft journal (B).

When the rod seizes to the crankshaft, the rod and piston may both break causing other damage. If rod seizes, inspect block carefully for cracks or damage before rebuilding engine.

Crankshaft and connecting rod damage can result from:

1. Engine run low on oil or without oil.
2. Oil slinger broken off bearing cap.
3. Oil hole in connecting rod plugged.
4. Oil not changed regularly.
5. Bearing cap installed incorrectly.

Evidence of score marks on rod bearing (E) indicates impurities in the oil or engine run low or without oil.

Replace rod (A) showing scratch marks or deep scores in the bearing area.

IMPORTANT: Be sure slinger (C) on rod cap (D) is intact...not cracked, bent or chipped.

Bent rods can be straightened with a rod aligner.

NOTE: New rods (A) and caps (D) are available only as a matched set for service. If either is damaged, both must be replaced.

Inspecting Crankshaft Journal and Connecting Rod Clearance

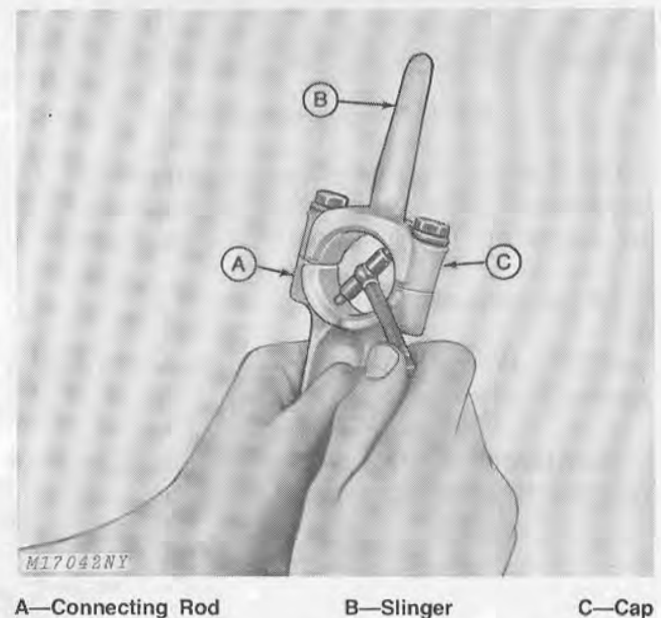

Fig. 17—Measuring I.D. of Connecting Rod

Measure fit of rod and cap to crankshaft journal. Install connecting rod cap in place and tighten to the specified torque. Measure the inside diameter of the connecting rod (A) at several places, Fig. 17.

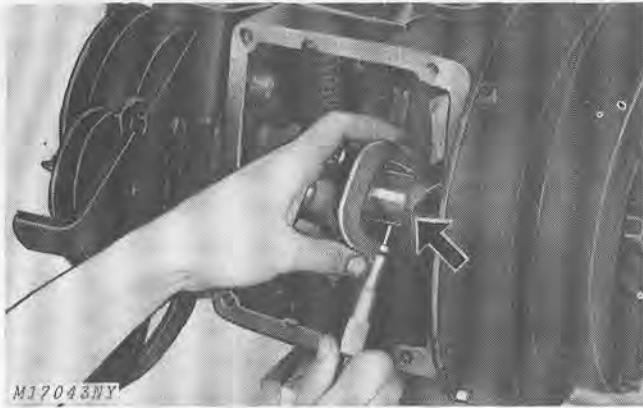

Fig. 18-Measuring Crankshaft

Measure the outside diameter of the crankshaft connecting rod journal, Fig. 18.

Compare the measurements between the connecting rod I.D. and the crankshaft journal O.D. These two measurements will give the proper clearance. See "Specifications," page 20-25-1.

An undersize rod and cap, 0.010-inch (0.254 mm), is available for service.

A competent machine shop can turn the journal down 0.010-inch (0.254 mm).

IMPORTANT: Always turn the crankshaft journal down when possible and install a new rod. This is the least expensive method of repair.

Inspecting and Repairing Cylinder Block

Thoroughly clean the cylinder block and check for cracks.

In any area where cracks may be suspected, coat the area with a mixture of 25 percent kerosene and 75 percent light engine oil.

Wipe the area dry and immediately apply a coating of zinc oxide dissolved in wood alcohol. If a crack is present, the coating will become discolored at the defective area.

Replace block if cracked.

NOTE: A short block is available for service.

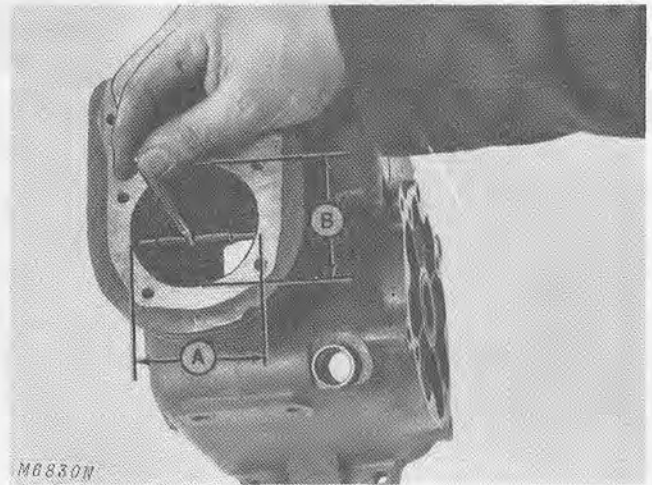

A—Parallel Measurement B—Right Angle Measurement

Fig. 19-Measuring Cylinder Bore

To measure cylinder bore, Fig. 19, use a cylinder dial gauge, an inside micrometer or a telescoping gauge and outside micrometer.

Measure cylinder bore as follows:

1. Measure the bore parallel (A) to the crankshaft at the top end of ring travel zone.
2. Measure the bore in the same position at the bottom end of ring travel zone.
3. Measure the bore at right angles (B) to the crankshaft at the top end of ring travel zone.
4. Measure the bore in the same position at the bottom end of ring travel zone.

Compare the measurements taken in Steps 1 and 3 above to find the out-of-round wear at the TOP end of the bore.

Compare the measurements taken in Steps 2 and 4 above to find the out-of-round wear at the BOTTOM end of the bore.

Compare the results of measurements taken in Steps 1, 2, 3 and 4 to find out whether or not the bore has worn tapered.

Deglazing Cylinder Bore

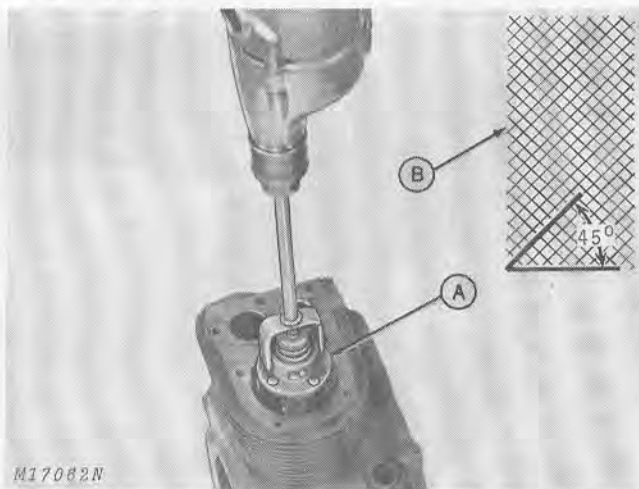

A—Deglazing Tool B—Deglazing Hone Pattern

Fig. 20—Deglazing Cylinder Bore

If cylinder is within tolerance and not damaged, lightly deglaze cylinder bore. Deglazing provides faster more positive seating of new piston rings, and also helps retain lubrication on cylinder walls during break-in period.

Operate the deglazing tool vertically to provide a cross-hatch pattern. See insert, Fig. 20. Follow tool manufacturer's recommendations.

Boring Cylinder Block

Reboring of the cylinder block is necessary when the bore is damaged or not within the specified tolerance.

NOTE: Cylinder should be rebored for 0.010 (0.254 mm), 0.020 (0.508 mm) or 0.030 (0.762 mm)-inch oversize pistons. These are the oversizes offered for service.

Use a "hone" for reboring the cylinder. Use coarse honing stones for removing most of the bore and medium honing stones for finishing. Use hones for cast iron. BE SURE the correct hone is used and that stones are not worn.

1. Anchor the cylinder block before reboring.
2. Set the drill press to operate from 450 to 700 rpm.
3. Lower the hone to the point where the lower end extends 1/2 to 3/4-inch (12.70 to 19.05 mm) past the end of the cylinder block.

4. Rotate the adjusting nut on the hone until the stones come in contact with the cylinder wall at the narrowest point.

5. Turn the hone by hand. If you cannot turn it, the hone is too tight. Loosen hone until it can be turned by hand.

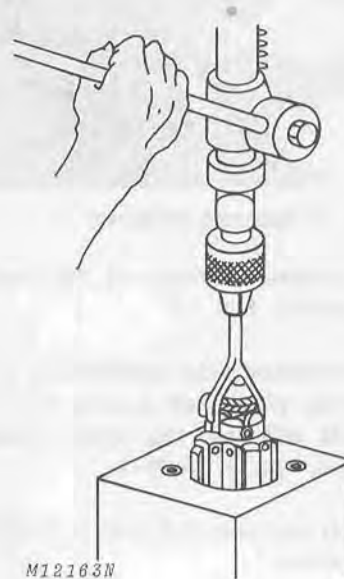

Fig. 21—Honing the Cylinder

6. Start the drill. Move the hone up and down in the cylinder approximately 40 cycles per minute, Fig. 21. Follow the hone manufacturer's recommendations.

IMPORTANT: Some hones require oil and some will not work with even a small amount of oil on the cylinder wall.

7. Check the diameter of the cylinder regularly during honing. (Stop the drill before measuring and remove the hone from the cylinder).

8. When the cylinder is approximately 0.002-inch (0.050 mm) within the desired bore specification, change to medium stones and finish the bore. Finish should not be perfectly smooth, but should have a 45 degree cross hatch pattern.

9. Clean the cylinder thoroughly. Use soap, warm water and clean rag. Clean the cylinder wall for a "white glove" inspection. A clean white rag should not show soil from the cylinder wall.

IMPORTANT: DO NOT use solvent or gasoline because these fluids only wash all the oil from the cylinder wall. They do not remove metal particles produced during honing.

10. Dry the cylinder and coat it with engine oil.

NOTE: Cylinder boring can be done by a competent small engine repair shop if facilities are not available at the dealership.

Inspecting Main Bearings

Main bearings turn in an oil mist and will not normally need replacing.

Check for unusual wear such as race turning with bearing or bearing deflection caused by excessive engine lugging.

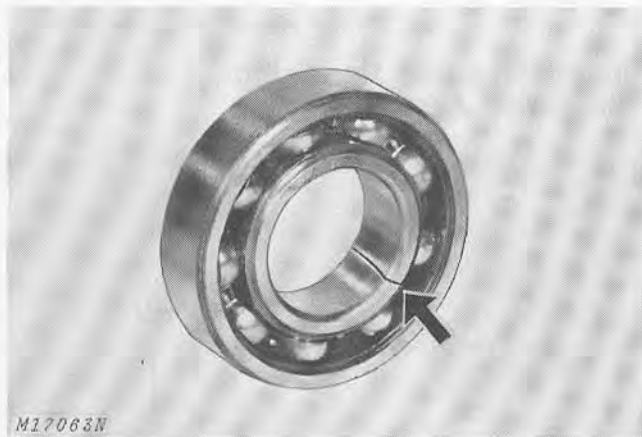

Fig. 22-Bearing Cracked During Installation

Bearings allowed to "cock" while installing them may cause the bearing to crack, Fig. 22.

Always use a bearing driver to install bearings.

If the inner bearing ring fits loose on the crankshaft, rotation of the shaft within the inner ring will scuff loose small particles of metal.

The small metal particles get into the bearing causing wear on the balls and race. This makes noisy engine operation, shortened bearing life and eventual bearing failure.

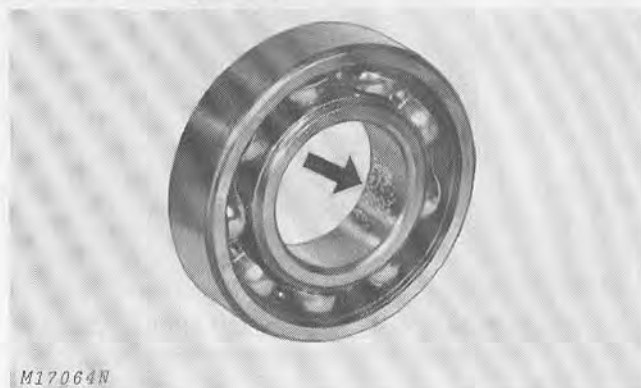

Fig. 23-Bearing Inner Race Wear

The condition is identified by scoring or abrasion on the I.D. of the inner ring, Fig. 23.

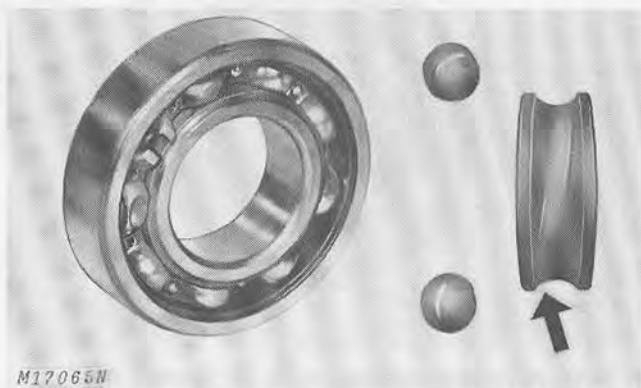

Fig. 24-Misaligned Bearing

Misaligned bearings, cause undue wear, heat by friction and eventual failure, Fig. 24. Note the crooked ball path in the raceway, oval appearance of the balls and wear on the separator caused by rubbing against the race.

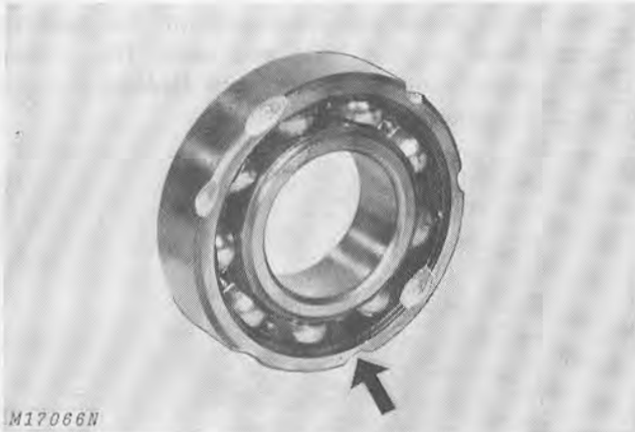

Fig. 25-Nicks in Outer Race Caused by Using Chisel or Driftpin to Remove or Install Bearing

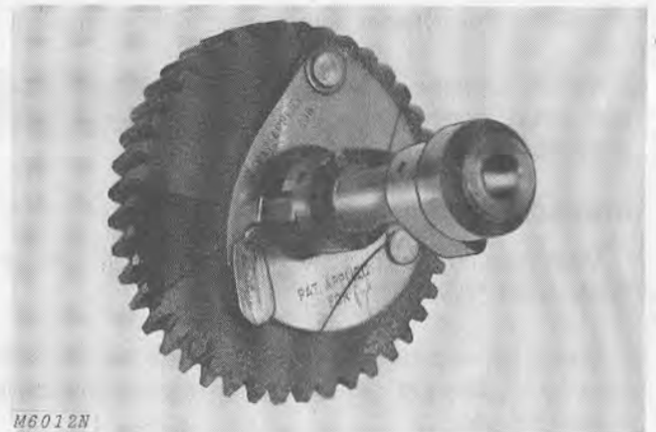

Fig. 27-ACR Mechanism

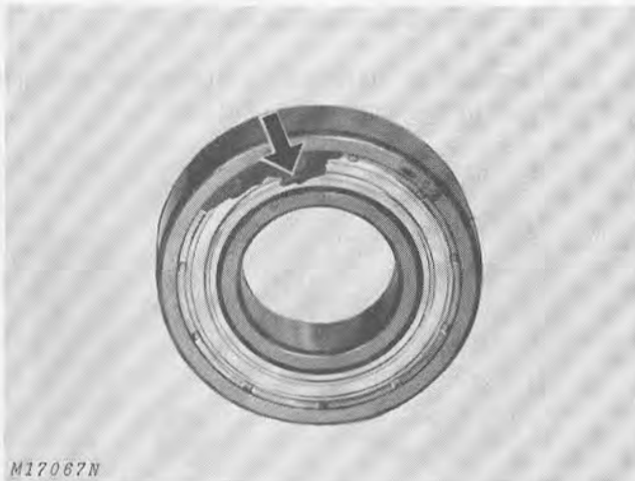

Fig. 26-Oil Seal Damage Caused by Careless Installation with Sharp Tool

Figs. 25 and 26 show bearing damage caused by careless installation.

Inspecting Camshaft and Camshaft Pin

Inspect camshaft gear and camshaft driving gear on crankshaft for worn, cracked, or broken teeth.

Inspect ACR mechanism, Fig. 27, for proper operation. Return spring should be replaced if broken or not functioning properly.

Inspect camshaft pin for wear. Camshaft pin-to-camshaft clearance should not exceed 0.0035 inch (0.0889 mm).

The camshaft pin should be a loose fit in the fly-wheel side of cylinder block but an interference fit in the PTO side. See Group 25 "Specifications" for details.

Inspecting and Repairing Governor Assembly

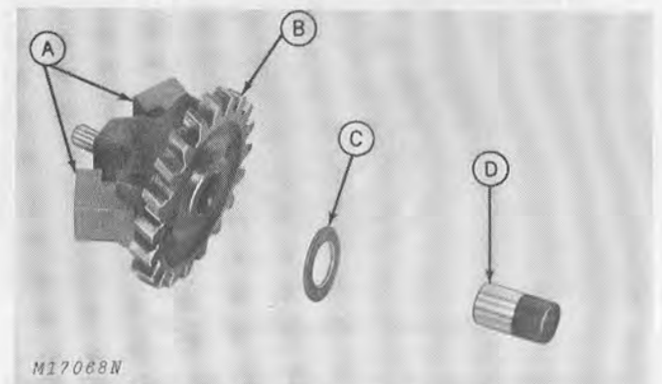

A—Governor Weights
B—Governor Gear
C—Thrust Washer
D—Stub Shaft

Fig. 28-Governor Gear Assembly

The governor gear assembly, Fig. 28, will not normally show much wear. Be sure weights (A) and governor center pin operate freely and that gear teeth are in good condition.

The stub shaft (D) is replaceable. Remove expansion plug from block and press shaft into valve chamber. Press new stub shaft into block until it protrudes 3/8 inch (9.525 mm) from the boss area.

Apply a light film of sealant to expansion plug and install in block. Seal plug with a large diameter punch.

Inspecting Cross Shaft Assembly

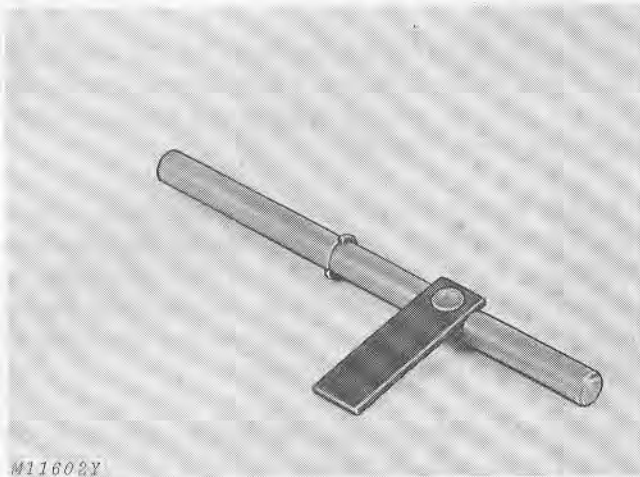

Fig. 29-Cross Shaft Assembly

Make sure arm is securely attached to cross shaft, Fig. 29. If rivet is loose, or if arm is not perpendicular to shaft, the cross shaft assembly must be replaced.

Engines are originally equipped with a spacer on the bushing end of the cross shaft. Replacement cross shafts, however, may have a snap ring rather than the spacer.

The cross shaft is supported by a bushing nut on one end and a replaceable bearing on the other end. Inspect the bushing and bearing for excessive wear. Oil seepage could result past a loose fit in the bushing nut.

The replacement bearing may be a needle bearing. Cross shaft end play is controlled by the position of this bearing. Start the new bearing into the block and refer to "Assembly" to obtain proper position.

Replacing Ring Gear

If inspection reveals broken or damaged ring gear teeth, the ring gear must be replaced.

Break the ring gear off the flywheel with a chisel or heat the ring gear to remove it.

The new ring gear must be expanded with heat before installation. Place the heated gear on the flywheel and carefully press or tap it into place. The gear will contract when cool to form a tight fit.

IMPORTANT: Use care when working with the flywheel. The flywheel has a ceramic magnet ring which can be damaged easily.

ASSEMBLY

Assembling Governor Assembly

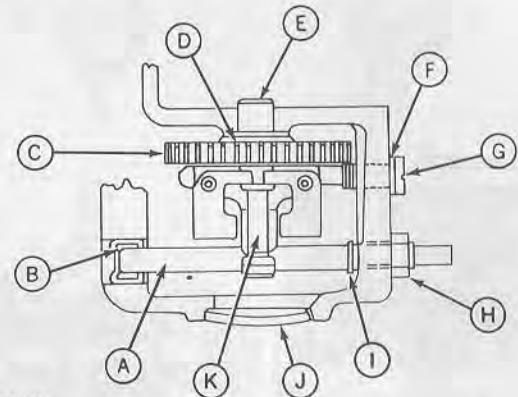

M17069N

- | | |
|------------------|------------------|
| A—Cross Shaft | F—Gasket |
| B—Needle Bearing | G—Stop Pin |
| C—Governor Gear | H—Bushing Nut |
| D—Thrust Washer | I—Snap Ring |
| E—Stub Shaft | J—Expansion Plug |
| | K—Pin |

Fig. 30-Cross Section of Governor Assembly

Install thrust washer (D, Fig. 30) and then governor gear (C) over stub shaft (E). Install stop pin (G) with gasket (F) to hold governor gear (C) in place.

Install cross shaft (A) into place from inside block. Snap ring (I) or spacer on cross shaft (A) must be on bushing nut (H) end of shaft. Install bushing nut (H). DO NOT overtighten because this will restrict free movement of cross shaft (A).

Check cross shaft end play for 1/64 to 1/32-inch (0.397 to 0.794 mm) movement. Adjust end play by tapping the needle bearing (B) in or out of the block.

Spin the governor gear (C) to be sure all components operate freely.

Installing Crankshaft Bearings

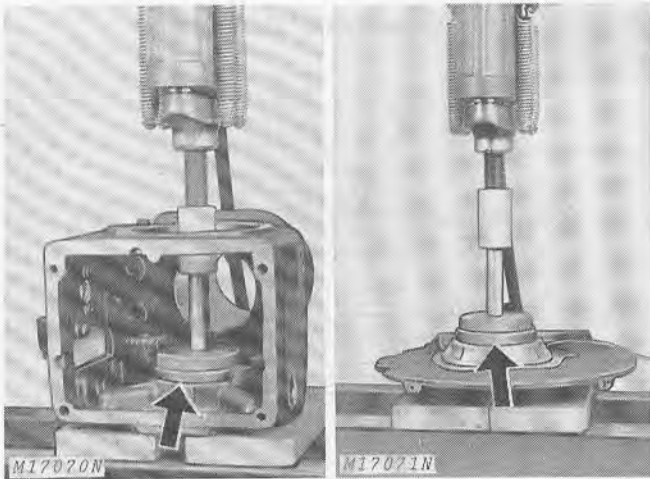

Fig. 31-Installing Crankshaft Bearings

With cylinder block and bearing plate properly supported, press bearings, Fig. 31, into place until they bottom in bore.

IMPORTANT: Press on outer race to prevent bearing damage. Be certain bearings are not cocked in bore.

Do not install oil seals until after installing crankshaft.

Installing Camshaft

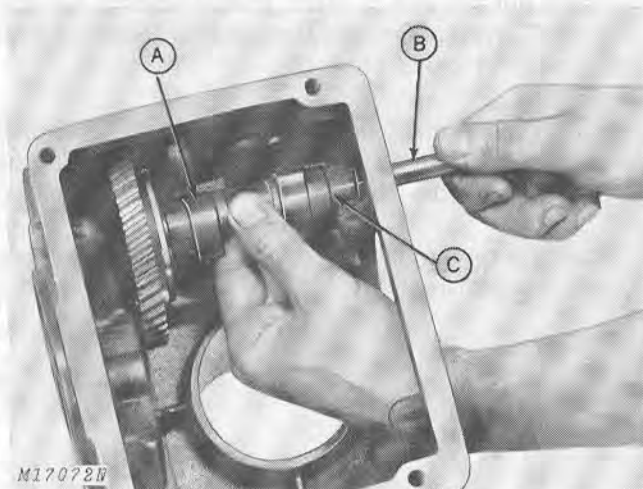

A—Camshaft B—Camshaft Pin C—Spacing Washer

Fig. 32-Installing Camshaft

Turn cylinder block upside down and insert tappets into guides from which they were removed.

Install camshaft (A) into position, Fig. 32. Lubricate camshaft pin (B) and insert it from bearing plate side of block, placing spacing washer (C) between camshaft and block, Fig. 32.

Before driving camshaft pin (B) into place, check camshaft end play. End play should be between 0.005 and 0.010 inch (0.127 to 0.254 mm). Add or remove spacing washers (C) as necessary to obtain proper end play. Spacing washers are available in 0.005 and 0.010-inch thicknesses.

Drive camshaft pin (B) into block until flush on bearing plate side of block.

Spin camshaft to be certain camshaft gear and governor gear are properly meshed.

Installing Crankshaft

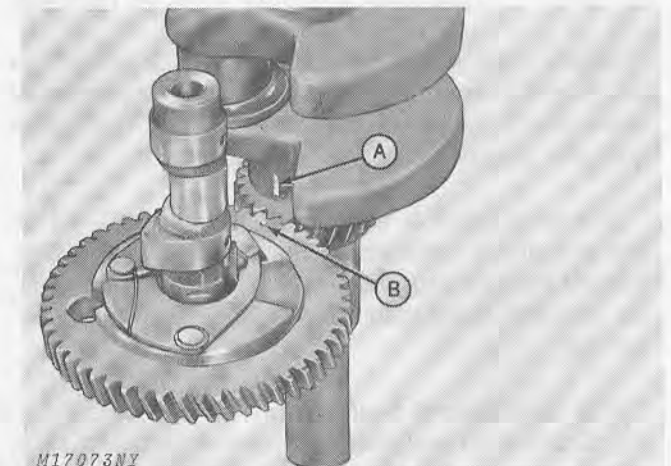

A—Standard Timing Mark
B—Camshaft Gear Timing Mark

Fig. 33-Aligning Timing Marks

Place block in arbor press and carefully insert crankshaft into PTO end bearing. Align timing marks, Fig. 33, on crankshaft and camshaft.

Press crankshaft into bearing until shoulder bottoms on inner race. Check timing marks to be sure they are still in alignment.

Installing Bearing Plate

Crankshaft end play is controlled with gaskets between cylinder block and bearing plate. Initial use of one thick 1/32-inch (0.794 mm) and two thin 0.010-inch (0.254 mm) gaskets should bring end play within limits. However, this must be checked after bearing plate is installed.

IMPORTANT: Install thick gasket next to cylinder block.

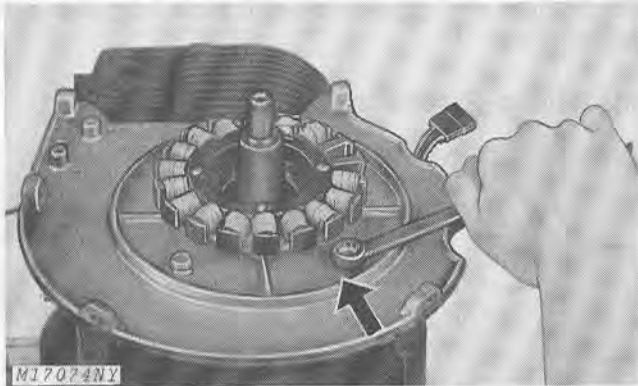

Fig. 34-Installing Bearing Plate

Carefully tap bearing plate with bearing onto crankshaft using a soft mallet. Tap each side alternately to prevent binding. Tap only enough to allow four cap screws to be inserted and started into block; then, pull bearing plate into place by evenly tightening the four cap screws, Fig. 34.

Seat the bearings by first tapping the flywheel end and then the PTO end of the crankshaft with a mallet.

Measure the distance between the bearing inner race and the crankshaft shoulder (PTO) end with a feeler gauge, Fig. 35. Proper end play is 0.003 to 0.020 inch (0.076 to 0.508 mm).

Add or remove gaskets from between bearing plate and block to obtain proper end play.

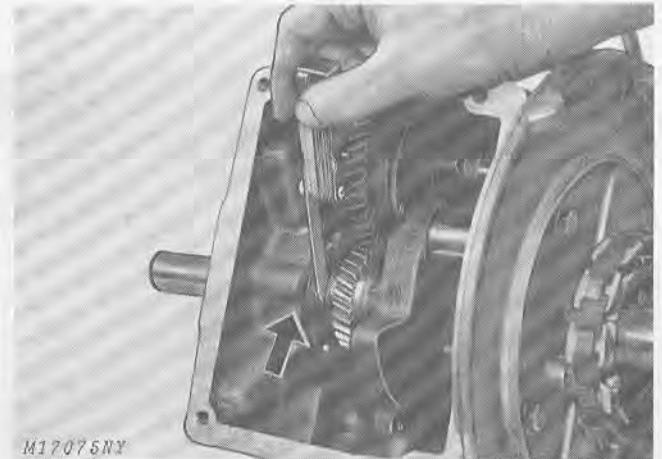
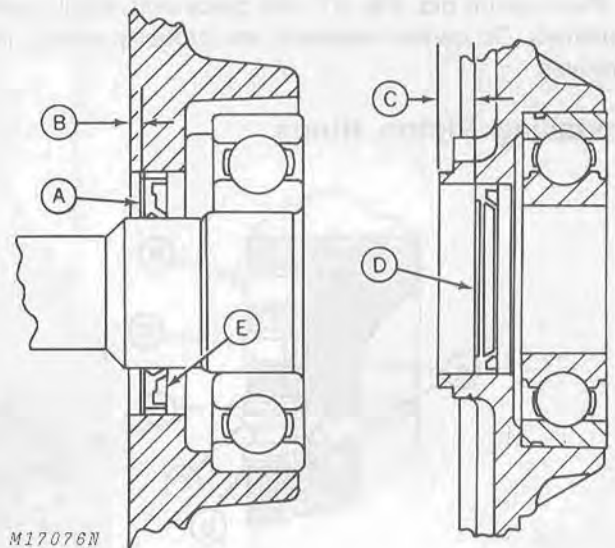

Fig. 35-Measuring Crankshaft End Play

Installing Oil Seals

Lubricate oil seal lips with oil prior to installation. Seals must be installed with lip facing inward, "numbers out."



- A—PTO Seal
- B—Seal Depth 1/8-inch (3.175 mm)
- C—Seal Depth 0.730-inch (18.54 mm)
- D—Flywheel Seal
- E—Open Side

Fig. 36-Proper Oil Seal Position

Use a seal sleeve tool if available when installing seals onto crankshaft. Using a seal driver of proper size, drive seals squarely to dimensions shown in Fig. 36.

Installing Piston Pin

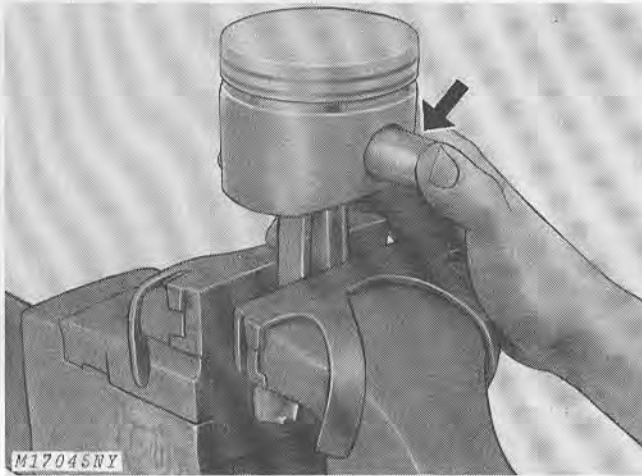
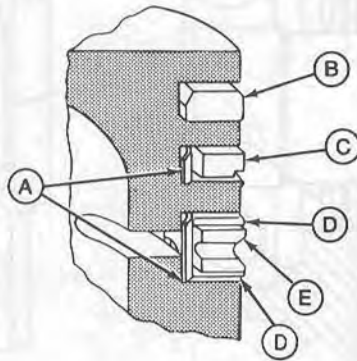

Fig. 37-Installing Piston Pin

Clamp connecting rod in a soft-jawed vise. Liberal-ly coat piston, piston pin, and connecting rod with oil.

Push piston pin, Fig. 37, into place and install new retainers. Be certain retainers are properly seated in grooves.

Installing Piston Rings



- A—Expanders
- B—Chrome Ring (Bevel Up)
- C—Cast Iron Ring (Scraper Groove Down)
- D—Chrome Steel Rails
- E—Cast Iron Spacer

Fig. 38-Piston Ring Assembly

Use a piston ring expander for ring installation to avoid twisting or stretching rings which could permanently distort rings and reduce performance.

Install oil control ring first, starting with expander (A, Fig. 38). Spiral lower chrome rail (D) into place, install cast iron spacer (E), and then spiral upper chrome rail (D) into place.

Install expander (A) behind lower compression ring (C) and install compression rings as shown in Fig. 38. Stagger end gaps to prevent gaps from being in alignment.

Installing Piston and Connecting Rod

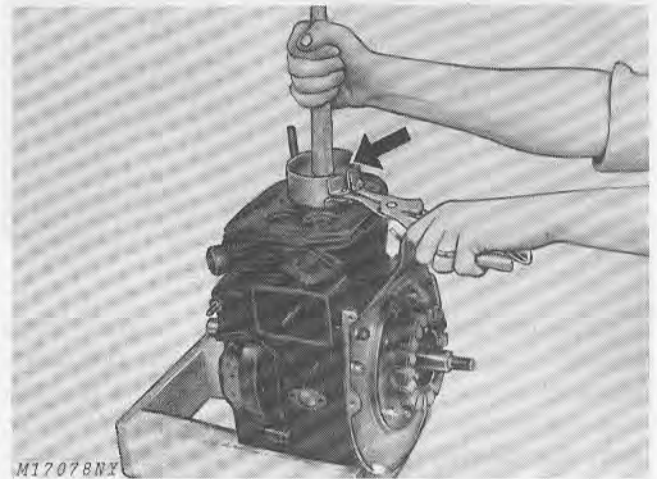
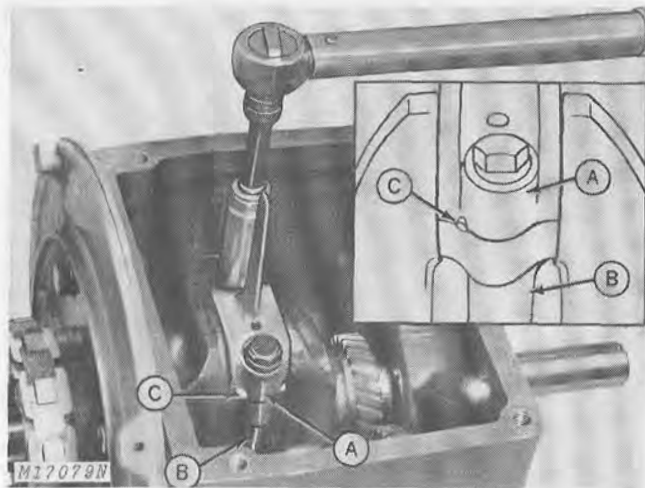

Fig. 39-Installing Piston in Cylinder

Coat piston, rings and crankshaft journal with oil. Install piston into cylinder with match mark on connecting rod facing flywheel side of engine.

Compress rings with a ring compressor and gently push piston down with hammer handle, Fig. 39, until connecting rod is in position on crankshaft journal.



A—Rod Cap B—Rod C—Match Marks

Fig. 40-Installing Rod Cap

Coat rod cap (A, Fig. 40) with oil and install so that match marks (C) align and face flywheel side of engine.

Lubricate and install cap screws, lock washers, and flat washers (sharp edge toward rod cap). Torque cap screws to 25 ft-lbs (33.9 Nm).

Installing Oil Pan

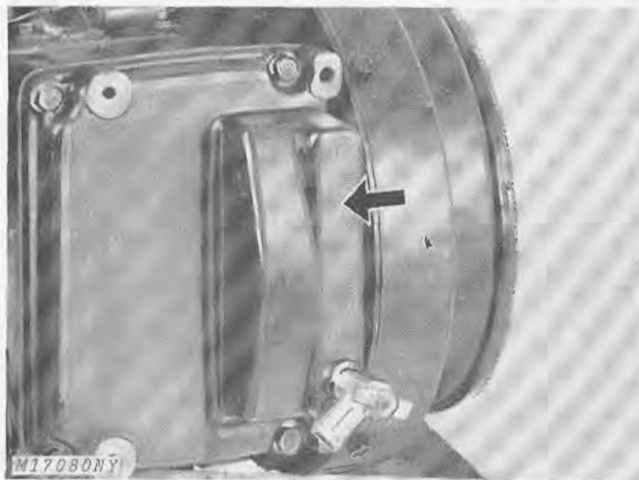

Fig. 41-Installing Oil Pan

Install oil pan, Fig. 41, using new gasket. The sump must be on flywheel side of engine. Tighten cap screws evenly.

Installing Valves and Breather Assembly

Refer to Group 10 of this section for valve and breather maintenance and assembly.

Installing Cylinder Head

IMPORTANT: Always use a new head gasket. Install head gasket dry. Do not use Permatex or other sealant on gasket.

Clean and apply a light film of oil to head bolt threads to insure an accurate torque reading. Install washers on head bolts with sharp edges down against cylinder head.

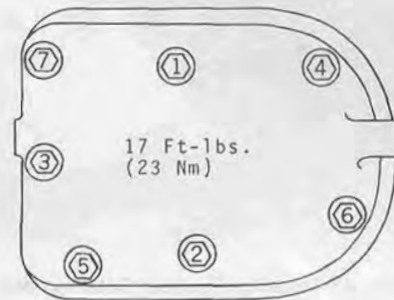

M17021N

Fig. 42-Torquing Sequence For 200 Tractor

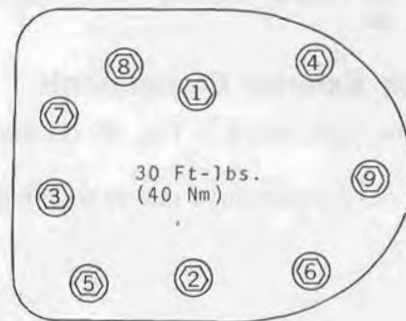

M17022N

Fig. 43-Torquing Sequence For
210, 212 and 214 Tractors

Torque all cylinder head bolts evenly and in the correct sequence, Figs. 42 and 43. This prevents uneven stresses in the cylinder wall. Torque head bolts to 17 ft-lbs (23 Nm) on 200 Tractors and 30 ft-lbs (40.6 Nm) on 210, 212 and 214 Tractors.

Installing Flywheel

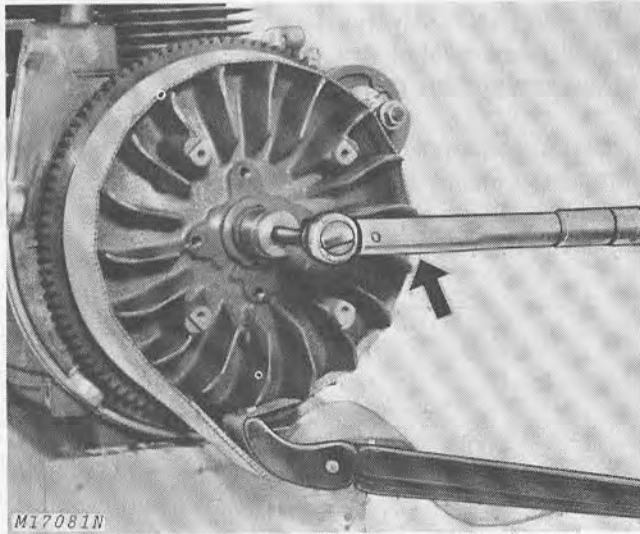

Fig. 44-Torquing Flywheel Retaining Nut

Place square key in crankshaft keyway. Place flywheel on crankshaft and secure with flat washer and retaining nut. Torque retaining nut to 60 ft-lbs (81.36 Nm), Fig. 44.

Installing Exterior Components

Install the parts listed in Fig. 45 on the engine.

NOTE: Set breaker point gap to 0.020-inch (0.508 mm).

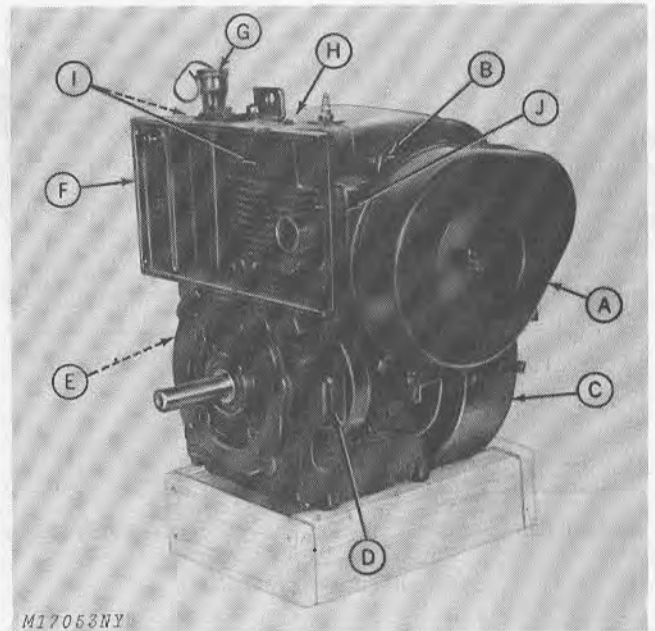

- A—Air Cleaner and Carburetor
- B—Governor Linkage and Breather Assembly
- C—Blower Housing
- D—Breaker Cover and Points
- E—Starter Motor
- F—Air Duct
- G—Oil Fill Tube
- H—Head Baffle
- I—Cylinder Baffle and Cylinder Head
- J—Air Side Baffle

Fig. 45-Exterior Components

Installing Engine in Tractor

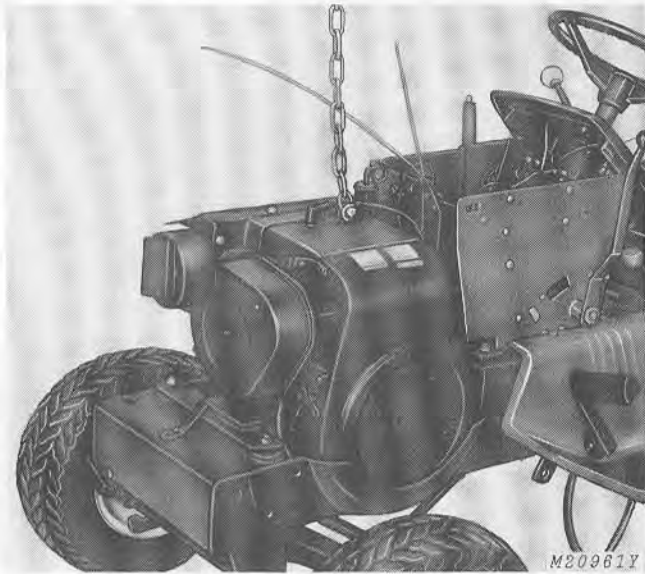

Fig. 46-Installing Engine in Tractor

1. Install engine in tractor. Before engine is completely in place, install idler to engine and replace idler spring.
2. Secure engine to base.
3. Install PTO clutch. Adjust brake shoe and connect clutch arm.
4. Install primary and secondary drive belts.

5. Install choke and throttle cables to carburetor.
6. Install fuel line, air filter base and air filter. Open fuel shut-off at tank.
7. Connect coupler between main wiring harness and engine.
8. Install battery cables (positive cable first).
9. Install hood and cowl assembly, grill and side panels.
10. Replace crankcase oil.

RUN-IN PROCEDURE

IMPORTANT: After recondition, engine must be "run-in" on non-detergent type oil and under load for a period of 5 hours. This allows sufficient time to seat the piston rings.

After the 5-hour "run-in" period, drain the non-detergent oil and fill crankcase with oil of type specified in Section 10, Group 15.

DO NOT use non-detergent oil after the 5-hour "run-in" period.

Let engine cool, then retorque cylinder head bolts.

Installing Engine in Tractor



1. Install engine in tractor. Before engine is lowered in place, install drive and idler rollers.
2. Secure engine to frame.
3. Install PTO shaft. Adjust drive shaft end cone and clutch wire.
4. Install primary and secondary drive belts.
5. Install engine in tractor. Before engine is lowered in place, install drive and idler rollers.

RUN-IN PROCEDURE

IMPORTANT: After recondition, engine must be "run-in" on non-detergent type oil and under load for a period of 8 hours. This allows sufficient time to seat the piston rings.

After the 8-hour "run-in" period, clean the engine, tighten all oil drainers with oil as specified in Section 10, Group 10.

DO NOT use non-detergent oil until the 8-hour "run-in" period.

Let engine cool, then remove cylinder head bolts.

Group 25 SPECIFICATIONS

SPECIFICATIONS

Item	200 Tractor K181QS Engine	210 Tractor K241AQS Engine	212 Tractor K301AQS Engine	214 Tractor K321AQS Engine	Wear Tolerance
Displacement	18.6 cu. in. (304.8 cc)	23.9 cu. in. (391.65 cc)	29.07 cu. in. (476.37 cc)	31.27 cu. in. (528.44 cc)	—
Horsepower	8 @ 3600 rpm	10 @ 3600 rpm	12 @ 3600 rpm	14 @ 3600 rpm	—
Engine compression (1000 rpm)	110 to 120 psi	110 to 120 psi	110 to 120 psi	110 to 120 psi	—
Engine compression (ACR 400 rpm)	37 to 50 psi	37 to 50 psi	37 to 50 psi	37 to 50 psi	Valves must be seated, ± 50 rpm will vary compression ± 5 psi proportionately.
ACR timing	32 to 40° BTDC	32 to 40° BTDC	32 to 40° BTDC	32 to 40° BTDC	—
Spark plug gap	0.025 in. (0.635 mm)	0.035 in. (0.889 mm)	0.035 in. (0.889 mm)	0.035 in. (0.889 mm)	—
Cylinder bore (new)	2.9375 in. (76.21 mm)	3.251 in. (82.57 mm)	3.375 in. (85.73 mm)	3.500 in. (88.9 mm)	0.003 in. (0.0762 mm)
Stroke	2-3/4 in. (69.85 mm)	2-7/8 in. (73.03 mm)	3-1/4 in. (82.55 mm)	3-1/4 in. (82.55 mm)	—
Crankshaft end play	0.002 to 0.023 in. (0.0508 to 0.5842 mm)	0.003 to 0.020 in. (0.076 to 0.508 mm)	0.003 to 0.020 in. (0.076 to 0.508 mm)	0.003 to 0.020 in. (0.076 to 0.508 mm)	—
Crankshaft journal-to-connecting rod side clearance	0.005 to 0.016 in. (0.1270 to 0.4064 mm)	0.007 to 0.016 in. (0.1778 to 0.4064 mm)	0.007 to 0.016 in. (0.1778 to 0.4064 mm)	0.007 to 0.016 in. (0.1778 to 0.4064 mm)	—
Crankshaft journal length (connecting rod)	1.1230 to 1.1265 in. (28.52 to 28.61 mm)	1.179 to 1.181 in. (29.95 to 29.97 mm)	1.1790 to 1.1825 in. (29.95 to 30.04 mm)	1.1790 to 1.1825 in. (29.95 to 30.04 mm)	—
Crankshaft journal diameter connecting rod bearing	1.1855 to 1.1860 in. (30.11 to 30.12 mm)	1.4995 to 1.5000 in. (38.09 to 38.10 mm)	1.4995 to 1.5000 in. (38.09 to 38.10 mm)	1.4995 to 1.5000 in. (38.09 to 38.10 mm)	-0.0015 in. (-0.038 mm)
Main bearings (crankshaft journal)	1.1811 to 1.1814 in. (29.99 to 30.00 mm)	1.5743 to 1.5747 in. (39.98 to 39.99 mm)	1.5745 to 1.5749 in. (39.99 to 40.00 mm)	1.5745 to 1.5749 in. (39.99 to 40.00 mm)	—
Connecting rod bore (large end)	1.1870 to 1.1875 in. (30.14 to 30.16 mm)	1.5010 to 1.5017 in. (38.12 to 38.14 mm)	1.5010 to 1.5017 in. (38.12 to 38.14 mm)	1.5010 to 1.5017 in. (38.12 to 38.14 mm)	—
Connecting rod bore (small end)	0.6255 to 0.6258 in. (15.88 to 15.89 mm)	0.8596 to 0.8599 in. (21.83 to 21.84 mm)	0.8757 to 0.8760 in. (22.24 to 22.25 mm)	0.8757 to 0.8760 in. (22.24 to 22.25 mm)	—
Connecting rod-to-crankshaft journal running clearance	0.001 to 0.002 in. (0.0254 to 0.0508 mm)	0.001 to 0.002 in. (0.0254 to 0.0508 mm)	0.001 to 0.002 in. (0.0254 to 0.0508 mm)	0.001 to 0.002 in. (0.0254 to 0.0508 mm)	0.0035 in. (0.0889 mm)
Connecting rod-to-piston pin clearance	0.0006 to 0.0011 in. (0.0152 to 0.0279 mm)	0.0003 to 0.0008 in. (0.0076 to 0.0203 mm)	0.0003 to 0.0008 in. (0.0076 to 0.0203 mm)	0.0003 to 0.0008 in. (0.0076 to 0.0203 mm)	0.0015 in. (0.0381 mm)
Cylinder head flatness (max.)	—	—	—	—	0.003 in. (0.0762 mm)
Cylinder taper (max.)	—	—	—	—	0.0015 in. (0.0381 mm)
Cylinder out-of-round (max.)	—	—	—	—	0.005 in. (0.127 mm)
Piston diameter (bottom skirt)	2.9332 to 2.9346 in. (74.50 to 74.53 mm)	3.2470 to 3.2480 in. (82.47 to 82.49 mm)	3.3705 to 3.3715 in. (85.61 to 85.63 mm)	3.4971 to 3.4985 in. (88.82 to 88.86 mm)	—
Piston pin-to-piston boss	0.000 to 0.0003 in. (0.000 to 0.0076 mm)	0.000 to 0.0003 in. (0.000 to 0.0076 mm)	0.000 to 0.0003 in. (0.000 to 0.0076 mm)	0.000 to 0.0003 in. (0.000 to 0.0076 mm)	Select to one thumb push fit.
Piston-to-cylinder bore (thrust face)	0.0045 to 0.007 in. (0.1143 to 0.1778 mm)	0.003 to 0.004 in. (0.0762 to 0.1016 mm)	0.003 to 0.004 in. (0.0762 to 0.1016 mm)	0.0035 to 0.0045 in. (0.0889 to 0.1143 mm)	—
Piston-to-cylinder bore (top of skirt)	0.006 to 0.008 in. (0.1524 to 0.2032 mm)	0.0075 to 0.0085 in. (0.1905 to 0.2159 mm)	0.0065 to 0.0095 in. (0.1651 to 0.2413 mm)	0.007 to 0.010 in. (0.1778 to 0.2540 mm)	—
Piston pin diameter	0.8247 to 0.8249 in. (15.86 to 15.87 mm)	0.8591 to 0.8593 in. (21.82 to 21.83 mm)	0.8752 to 0.8754 in. (22.23 to 22.24 mm)	0.8752 to 0.8754 in. (22.23 to 22.24 mm)	—
Ring side clearance (top ring)	0.0025 to 0.004 in. (0.0635 to 0.1016 mm)	0.002 to 0.004 in. (0.0508 to 0.1016 mm)	0.002 to 0.004 in. (0.0508 to 0.1016 mm)	0.002 to 0.004 in. (0.0508 to 0.1016 mm)	+0.002 in. (0.508 mm)

SPECIFICATIONS—Continued

Item	200 Tractor K181QS Engine	210 Tractor K241AQS Engine	212 Tractor K301AQS Engine	214 Tractor K321AQS Engine	Wear Tolerance
Ring side clearance (middle ring)	0.0025 to 0.004 in. (0.0635 to 0.1016 mm)	0.0015 to 0.003 in. (0.0381 to 0.0762 mm)	0.002 to 0.004 in. (0.0508 to 0.1016 mm)	0.002 to 0.004 in. (0.0508 to 0.1016 mm)	+0.002 in. (0.508 mm)
Ring side clearance (oil ring)	0.001 to 0.0025 in. (0.0254 to 0.0635 mm)	0.001 to 0.003 in. (0.0254 to 0.0762 mm)	0.001 to 0.003 in. (0.0254 to 0.0762 mm)	0.001 to 0.003 in. (0.0254 to 0.0762 mm)	+0.002 in. (0.508 mm)
Ring end gap	0.007 to 0.017 in. (0.1778 to 0.0431 mm)	0.010 to 0.020 in. (0.2540 to 0.5080 mm)	0.010 to 0.020 in. (0.2540 to 0.5080 mm)	0.010 to 0.020 in. (0.2540 to 0.5080 mm)	+0.010 in. (0.254 mm)
Camshaft pin-to-camshaft clearance	0.001 to 0.0035 in. (0.0254 to 0.0889 mm)	0.001 to 0.0035 in. (0.0254 to 0.0889 mm)	0.001 to 0.0035 in. (0.0254 to 0.0889 mm)	0.001 to 0.0035 in. (0.0254 to 0.0889 mm)	—
Camshaft pin-to-block (bearing plate end)	0.0005 to 0.002 in. (0.0127 to 0.0508 mm)	0.0005 to 0.002 in. (0.0127 to 0.0508 mm)	0.0005 to 0.002 in. (0.0127 to 0.0508 mm)	0.0005 to 0.002 in. (0.0127 to 0.0508 mm)	—
Camshaft pin-to-block (PTO end)	0.0015 to 0.003 in. (0.0381 to 0.0762 mm)	0.0015 to 0.003 in. (0.0381 to 0.0762 mm)	0.0015 to 0.003 in. (0.0381 to 0.0762 mm)	0.0015 to 0.003 in. (0.0381 to 0.0762 mm)	—
Camshaft pin-to-breaker cam	0.001 to 0.0035 in. (0.0254 to 0.0889 mm)	0.001 to 0.0025 in. (0.0254 to 0.0635 mm)	0.001 to 0.0025 in. (0.0254 to 0.0635 mm)	0.001 to 0.0025 in. (0.0254 to 0.0635 mm)	—
Camshaft end play	0.005 to 0.010 in. (0.127 to 0.254 mm)	0.005 to 0.010 in. (0.127 to 0.254 mm)	0.005 to 0.010 in. (0.127 to 0.254 mm)	0.005 to 0.010 in. (0.127 to 0.254 mm)	—
Valve stem clearance in guide (intake)	0.001 to 0.0025 in. (0.025 to 0.063 mm)	0.001 to 0.0025 in. (0.025 to 0.063 mm)	0.001 to 0.0025 in. (0.025 to 0.063 mm)	0.001 to 0.0025 in. (0.025 to 0.063 mm)	0.0045 in. (0.1143 mm)
Valve stem clearance in guide (exhaust)	0.0025 to 0.0040 in. (0.0635 to 0.1016 mm)	0.0025 to 0.0040 in. (0.0635 to 0.1016 mm)	0.0025 to 0.0040 in. (0.0635 to 0.1016 mm)	0.0025 to 0.0040 in. (0.0635 to 0.1016 mm)	0.0065 in. (1.651 mm)
Valve guide in block (interference)	0.0005 to 0.0020 in. (0.0127 to 0.0508 mm)	0.0005 to 0.0020 in. (0.0127 to 0.0508 mm)	0.0005 to 0.0020 in. (0.0127 to 0.0508 mm)	0.0005 to 0.0020 in. (0.0127 to 0.0508 mm)	—
Valve seat in block (exhaust) (interference)	0.002 to 0.004 in. (0.0508 to 0.1016 mm)	0.003 to 0.005 in. (0.0762 to 0.1524 mm)	0.003 to 0.005 in. (0.0762 to 0.1524 mm)	0.003 to 0.005 in. (0.0762 to 0.1524 mm)	—
Valve clearance (intake) (cold)	0.006 to 0.008 in. (0.1524 to 0.2032 mm)	0.008 to 0.010 in. (0.2032 to 0.2540 mm)	0.008 to 0.010 in. (0.2032 to 0.2540 mm)	0.008 to 0.010 in. (0.2032 to 0.2540 mm)	—
Valve clearance (exhaust) (cold)	0.015 to 0.017 in. (0.3810 to 0.4318 mm)	0.017 to 0.020 in. (0.4318 to 0.5080 mm)	0.017 to 0.020 in. (0.4318 to 0.5080 mm)	0.017 to 0.020 in. (0.4318 to 0.5080 mm)	—
Valve seat angle	44.5°	44.5°	44.5°	44.5°	—
Valve face angle	45°	45°	45°	45°	—
Valve seat width	1/32 in. (0.794 mm)	1/32 in. (0.794 mm)	1/32 in. (0.794 mm)	1/32 in. (0.794 mm)	1/16 in. (1.588 mm)
Valve tappet clearance in block	0.005 to 0.0020 in. (0.0127 to 0.0508 mm)	0.008 to 0.0023 in. (0.0203 to 0.0584 mm)	0.0008 to 0.0023 in. (0.0203 to 0.0584 mm)	0.0008 to 0.0023 in. (0.0203 to 0.0584 mm)	—
Minimum valve lift	0.25 in. (6.35 mm)	0.25 in. (6.35 mm)	0.25 in. (6.35 mm)	0.25 in. (6.35 mm)	—
Valve guide, I.D.	0.312 to 0.313 in. (7.924 to 7.950 mm)	0.312 to 0.313 in. (7.924 to 7.950 mm)	0.312 to 0.313 in. (7.924 to 7.950 mm)	0.312 to 0.313 in. (7.924 to 7.950 mm)	0.315 in. (8.001 mm)
Valve guide, depth	1-5/16 in. (33.34 mm)	1-15/32 in. (37.31 mm)	1-15/32 in. (37.31 mm)	1-15/32 in. (37.31 mm)	—
Valve stem, O.D. (intake)	0.3105 to 0.3110 in. (7.8867 to 7.8994 mm)	0.3105 to 0.3110 in. (7.8867 to 7.8994 mm)	0.3105 to 0.3110 in. (7.8867 to 7.8994 mm)	0.3105 to 0.3110 in. (7.8867 to 7.8994 mm)	0.3080 in. (7.8486 mm)
Valve stem, O.D. (exhaust)	0.3090 to 0.3095 in. (7.8486 to 7.8613 mm)	0.3090 to 0.3095 in. (7.8486 to 7.8613 mm)	0.3090 to 0.3095 in. (7.8486 to 7.8613 mm)	0.3090 to 0.3095 in. (7.8486 to 7.8613 mm)	3.3080 in. (7.8232 mm)
Valve face width	1/32 in. (0.794 mm)	1/32 in. (0.794 mm)	1/32 in. (0.794 mm)	1/32 in. (0.794 mm)	1/16 in. (1.588 mm)
Valve spring squareness	1/16 in. (1.588 mm)	1/16 in. (1.588 mm)	1/16 in. (1.588 mm)	1/16 in. (1.588 mm)	1/32 in. (0.794 mm)
Valve spring compressed (intake)	18 to 20 lbs. at 1-5/16 in. length (8.16 to 9.98 kg at 49.21 mm length)	43 to 49 lbs. at 1-5/16 in. length (19.50 to 22.23 kg at 49.21 mm length)	43 to 49 lbs. at 1-5/16 in. length (19.50 to 22.23 kg at 49.21 mm length)	43 to 49 lbs. at 1-5/16 in. length (19.50 to 22.23 kg at 49.21 mm length)	—

SPECIFICATIONS—Continued

Item	200 Tractor K181QS Engine	210 Tractor K241AQS Engine	212 Tractor K301AQS Engine	214 Tractor K321AQS Engine	Wear Tolerance
Valve spring compressed (exhaust)	18 to 22 lbs. at 1-5/16 in. length (8.16 to 9.98 kg at 49.21 mm length)	43 to 49 lbs. at 1-5/16 in. length (19.50 to 22.23 kg at 49.21 mm length)	43 to 49 lbs. at 1-5/16 in. length (19.50 to 22.23 kg at 49.21 mm length)	43 to 49 lbs. at 1-5/16 in. length (19.50 to 22.23 kg at 49.21 mm length)	—
Valve spring free length (intake)	1-3/4 in. (44.45 mm)	1-13/16 in. (46.04 mm)	1-13/16 in. (46.04 mm)	1-13/16 in. (46.04 mm)	—
Valve spring free length (exhaust)	1-3/4 in. (44.45 mm)	1-7/8 in. (47.63 mm)	1-7/8 in. (47.63 mm)	1-7/8 in. (47.63 mm)	—
Governor bushing-to-governor cross shaft clearance	0.0005 to 0.0020 in. (0.0127 to 0.0508 mm)	0.001 to 0.0025 in. (0.0254 to 0.0635 mm)	0.001 to 0.0025 in. (0.0254 to 0.0635 mm)	0.001 to 0.0025 in. (0.0254 to 0.0635 mm)	—
Governor gear-to-governor shaft	0.0005 to 0.0020 in. (0.0127 to 0.0508 mm)	0.0005 to 0.0020 in. (0.0127 to 0.0508 mm)	0.0005 to 0.0020 in. (0.0127 to 0.0508 mm)	0.0005 to 0.0020 in. (0.0127 to 0.0508 mm)	—
Ball bearing-to-cylinder block (interference)	0.0014 to 0.0029 in. (0.0355 to 0.0736 mm)	0.0006 to 0.0022 in. (0.0152 to 0.0558 mm)	0.0006 to 0.0022 in. (0.0152 to 0.0558 mm)	0.0006 to 0.0022 in. (0.0152 to 0.0558 mm)	—
Ball bearing-to-bearing plate (interference)	0.0014 to 0.0029 in. (0.0355 to 0.0736 mm)	0.0012 to 0.0028 in. (0.0304 to 0.0711 mm)	0.0012 to 0.0028 in. (0.0304 to 0.0711 mm)	0.0012 to 0.0028 in. (0.0304 to 0.0711 mm)	—
Ball bearing-to-crankshaft (interference too loose)	0.0002 to 0.0005 in. (0.0050 to 0.0127 mm)	0.0004 to 0.0005 in. (0.0101 to 0.0127 mm)	0.0004 to 0.0005 in. (0.0101 to 0.0127 mm)	0.0004 to 0.0005 in. (0.0101 to 0.0127 mm)	—

TORQUES FOR HARDWARE

Location	Torque	
	200 Tractor	210, 212, 214 Tractors
Cylinder head bolts	17 ft-lbs (23 Nm)	30 ft-lbs (41 Nm)
Connecting rod cap screws	17 ft-lbs (23 Nm)	25 ft-lbs (34 Nm)
Flywheel nut	50-60 ft-lbs (67-81 Nm)	60-70 ft-lbs (81-95 Nm)
Spark plug (cold)	27 ft-lbs (36 Nm)	27 ft-lbs (36 Nm)

SPECIFICATIONS - Continued

Part Name	Part Number	Part Number	Part Number	Part Number	Part Number
Alternator	205-1000	205-1000	205-1000	205-1000	205-1000
Alternator Drive Pulley	205-1000-1	205-1000-1	205-1000-1	205-1000-1	205-1000-1
Alternator Drive Pulley	205-1000-2	205-1000-2	205-1000-2	205-1000-2	205-1000-2
Alternator Drive Pulley	205-1000-3	205-1000-3	205-1000-3	205-1000-3	205-1000-3
Alternator Drive Pulley	205-1000-4	205-1000-4	205-1000-4	205-1000-4	205-1000-4
Alternator Drive Pulley	205-1000-5	205-1000-5	205-1000-5	205-1000-5	205-1000-5
Alternator Drive Pulley	205-1000-6	205-1000-6	205-1000-6	205-1000-6	205-1000-6
Alternator Drive Pulley	205-1000-7	205-1000-7	205-1000-7	205-1000-7	205-1000-7
Alternator Drive Pulley	205-1000-8	205-1000-8	205-1000-8	205-1000-8	205-1000-8
Alternator Drive Pulley	205-1000-9	205-1000-9	205-1000-9	205-1000-9	205-1000-9
Alternator Drive Pulley	205-1000-10	205-1000-10	205-1000-10	205-1000-10	205-1000-10

TORQUES FOR HARDWARE

Hardware	Torque	Hardware	Torque
Spark plug (cold)	25 ft-lbs (34 Nm)	5/16" nut (36 Nm)	25 ft-lbs (34 Nm)
Flywheel nut	80-90 ft-lbs (81-98 Nm)	5/8" nut (91 Nm)	80-90 ft-lbs (81-98 Nm)
Connecting rod-bolt screw	75 ft-lbs (101 Nm)	3/4" nut (121 Nm)	75 ft-lbs (101 Nm)
Cylinder head bolt	30 ft-lbs (41 Nm)	1 1/2" bolt (121 Nm)	30 ft-lbs (41 Nm)
		2 1/2" nut (181 Nm)	210-215 ft-lbs (284 Nm)

Section 30

FUEL SYSTEM

Group 5

GENERAL INFORMATION

CONTENTS

	Page		Page
GROUP 5 - GENERAL INFORMATION		GROUP 15 - AIR CLEANER	
Principle of Operation	5-2	General Information	15-1
Diagnosing Malfunctions	5-3	Servicing Air Cleaner	15-1
GROUP 10 - CARBURETOR		GROUP 20 - FUEL STRAINER AND FUEL TANK	
General Information	10-1	Fuel Strainer	20-1
Removal	10-1	Fuel Tank	20-1
Disassembly and Repair	10-1	GROUP 25 - FUEL PUMP	
Disassembling Carburetor	10-1	Kohler K181QS Engine	
Cleaning Carburetor	10-2	General Information	25-1
Inspecting Carburetor	10-2	Repair	25-1
Assembly	10-3	Kohler K241AQS, K301AQS and K321AQS Engines	
Installing Float Valve	10-3	Principle of Operation	25-3
Installing Float and Fuel Bowl	10-3	Diagnosis and Testing	25-4
Installation	10-4	Disassembly and Repair	25-5
Adjustment	10-4	Assembly	25-6
Governor-to-Carburetor Linkage		GROUP 30 - SPECIFICATIONS	
Adjustment	10-4	Specifications	30-1
Governor Speed Adjustment	10-5		
Carburetor Adjustment	10-6		
Float Damper Spring	10-6		

PRINCIPLE OF OPERATION

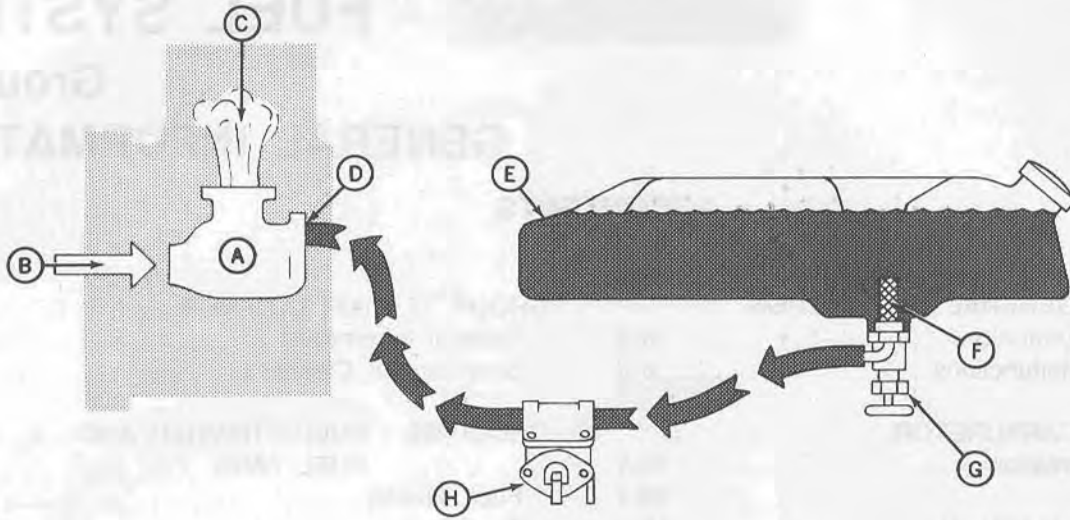

M17082

A—Carburetor
B—Air Intake
C—Fuel-Air Mixture
D—Fuel Intake

E—Fuel Tank
F—Strainer
G—Shut-Off Valve
H—Fuel Pump

Fig. 1-Fuel System

The fuel system, Fig. 1, consists of the fuel tank (E), strainer (F), shut-off valve (G), fuel pump (H) and carburetor (A).

The fuel pump (H) is operated by a cam on the engine camshaft and pumps fuel from the fuel tank (E) through the strainer (F) and shut-off valve (G) to the carburetor (A).

The side-draft, float-type carburetor (A) has three external adjustments: high-speed needle, idle mixture needle and idle stop screw.

A replaceable dry-type air cleaner element is used to filter incoming air to the carburetor.

DIAGNOSING MALFUNCTIONS

Hard Engine Starting

- Engine flooded.
- Gas tank vent restricted.
- High-speed and idle mixture needles not properly adjusted.
- Fuel inlet needle sticking to seat.
- Choke not operating properly.
- Fuel shut-off valve closed.
- Water, rust or stale fuel in gas tank.
- Carburetor gummed.
- Air lock in fuel line.
- Air filter element restricted.
- Faulty fuel pump.

Engine Stalling

- High-speed and idle mixture needles not properly adjusted
- Dirt, water, or ice in fuel system.
- Gas tank vent restricted.
- Fuel line restricted.
- Fuel strainer plugged.
- Air lock in fuel line.
- Air filter element restricted.
- Faulty fuel pump.

Rough Idle

- High-speed and idle mixture needles not properly adjusted.

Air leakage past damaged carburetor-to-engine gasket.

Air leakage past worn throttle plate shaft or bearing surfaces.

Float setting incorrect.

Air filter element restricted.

Dirt, water, or ice in fuel system.

Poor Acceleration

- High-speed and idle mixture needles not properly adjusted.
- Air filter element restricted.
- Throttle cable not adjusted properly.
- Sticky fuel inlet needle.
- Dirty or damaged high-speed mixture needle.
- Governor not adjusted properly.
- Dirt or paint on throttle return spring.

Engine Surging

- High-speed and idle mixture needles not properly adjusted.
- Dirt or paint on throttle return spring.
- Fuel strainer plugged.
- Faulty fuel pump.
- Governor linkage not adjusted properly.
- Too low on fuel.

DIAGNOSING MALFUNCTIONS—Continued

Flooding or Leaking Carburetor

- Sticking fuel inlet needle.
- Float setting incorrect.
- Float leaking.
- Fuel line or fitting loose.

No Fuel Reaches Carburetor

- Shut-off valve closed.
- Gas tank empty.
- In-line strainer clogged.
- Gas tank vent restricted.
- Fuel line clogged.
- Faulty fuel pump.

Group 10 CARBURETOR

GENERAL INFORMATION

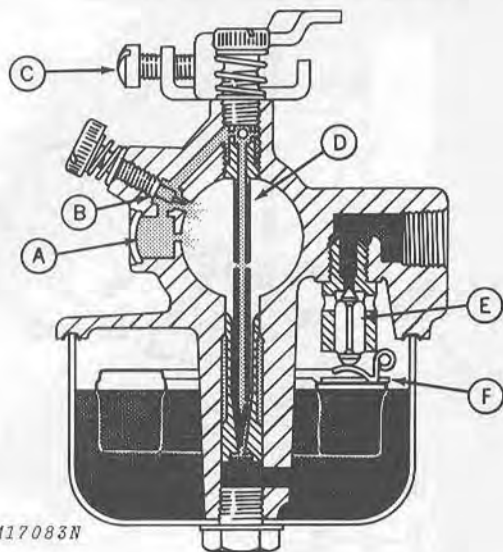

A—Accelerating Well
B—Idle Mixture Needle
C—Idle Stop Screw
D—High-Speed Mixture Needle
E—Float Valve
F—Float

Fig. 1-Cutaway View of Carburetor

Fuel enters the bowl through the float valve (E) and is controlled by the float (F), Fig. 1. Air entering the carburetor is controlled by the choke when starting. The air-fuel mixture entering the engine is regulated by the throttle valve which maintains uniform engine speed under varying loads by increasing or decreasing air-fuel flow.

Whenever the throttle is opened quickly to give extra power for a sudden load, an extra amount of fuel is required for a momentarily rich air-fuel mixture. The accelerating well (A) provides the extra fuel.

The carburetor has two mixture needles: one for high-speed (D), the other for low or idle speed (B).

The high-speed mixture needle (D) controls the amount of fuel entering the venturi at high engine speeds.

The idle mixture needle (B) controls the amount of fuel entering the engine when idling or at partial throttle settings.

The idle stop screw (C) controls the throttle setting for correct idle speed.

REMOVAL

1. Remove air cleaner and air cleaner base.
2. Disconnect fuel line from carburetor.
3. Disconnect link from governor arm at carburetor.
4. Loosen mounting cap screws enough to remove carburetor.
5. Disconnect choke cable from carburetor.

DISASSEMBLY AND REPAIR

Disassemble the carburetor before placing it in the cleaning solution. This will assure that the solution reaches all surfaces and parts.

Install the repair kit when servicing the carburetor. Always install new gaskets whenever the carburetor is disassembled.

Disassembling Carburetor

Remove fuel bowl, float valve, and seat.

Remove high-speed and idle mixture needles.

NOTE: Do not attempt to remove choke or throttle valves because screws securing valves to shafts are peened. Should valves require service, replace the carburetor body.

DISASSEMBLY AND REPAIR—Continued

Cleaning Carburetor

Clean all parts in John Deere PT503 Carburetor Cleaner or its equivalent.

IMPORTANT: Never clean holes or passages with small drill bits or wire. A slight enlargement or burring of these holes will change the performance of the carburetor. No method of cleaning other than cleaner should be used.

Place all metallic carburetor parts in a suitable basket and immerse basket in a container of carburetor cleaner. Agitate the basket in the cleaner to aid in dissolving deposits.

Allow parts to remain in the cleaning solution for one or two hours. Remove and rinse parts with fresh cleaner. Dry parts with compressed air. Never use rags or waste paper to dry the parts. Any lint may plug jets or channels and affect operation.

IMPORTANT: Never use compressed air to clean a completely assembled carburetor. To do so may cause the float to collapse.

Inspecting Carburetor

Inspect float (L) and float valve assembly (Q and R) for defects or wear, Fig. 2. If either is noticed, replace parts as required.

Float valves (Q) and seats (R) are available only as matched sets and should never be interchanged.

For a positive leak test, immerse the float (L) in hot water. Any leak can be detected at once by air bubbles escaping from the float. Do not attempt to repair the float if it leaks. Replace it.

Check float pin (P) and replace if worn.

Inspect tapered ends of mixture needles (A and G). If a ring has been cut in the tapered surface because the needle has been turned too tightly against the seat, replace the needle.

The seats for the high-speed and idle mixture adjusting needles are an integral part of the carburetor body casting and therefore cannot be removed or replaced.

Inspect carburetor body casting (I) and fuel bowl (M) for cracks or damaged sealing surface. Examine threaded holes for damaged threads.

Inspect choke and throttle shafts and bearing surfaces in carburetor body for excessive wear. Air leakage would result in poor engine performance and allow unfiltered air to enter the engine.

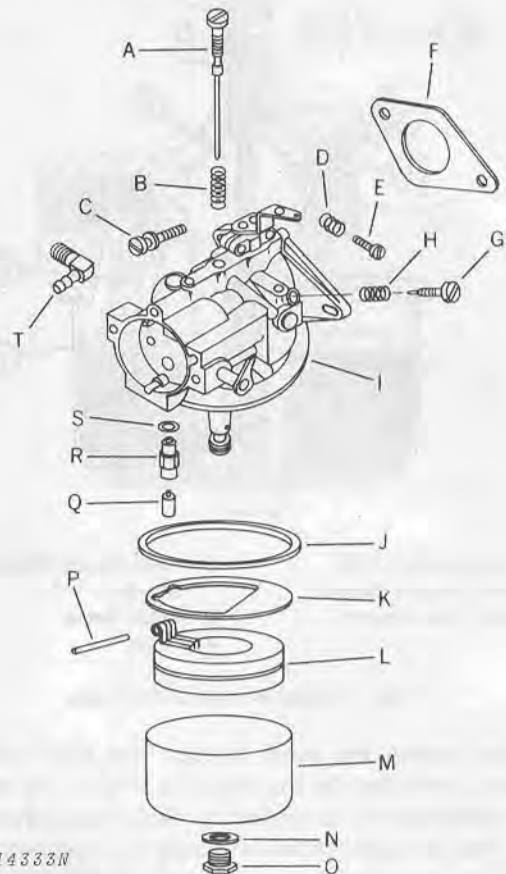

- | | |
|-----------------------------|-----------------------|
| A—High-Speed Mixture Needle | K—Bowl Gasket* |
| B—Spring | L—Float |
| C—Cap Screw | M—Bowl |
| D—Spring | N—Bowl Screw Gasket* |
| E—Idle Stop Screw | O—Bowl Screw |
| F—Gasket | P—Float Pin* |
| G—Idle Mixture Needle | Q—Float Valve* |
| H—Spring | R—Seat* |
| I—Carburetor Body | S—Gasket* |
| J—Bowl Ring Gasket* | T—Fuel Line Connector |

*Repair Kit Components

Fig. 2—Exploded View of Carburetor

IMPORTANT: Never clean holes or passages with small drill bits or wire. Dissolve all particles with carburetor cleaner.

Inspect throttle and choke valves for bends, cracks, or other damage. Replace carburetor if damaged.

Governor Speed Adjustment

200 Tractor

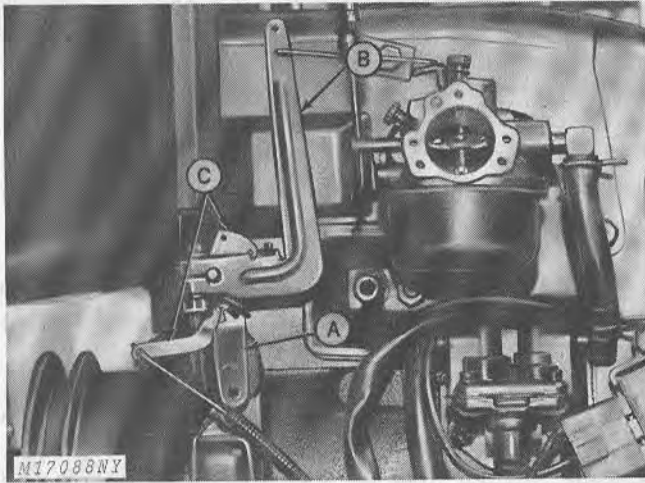

A—Speed Control Bracket C—Speed Control Disk
B—Governor Arm

Fig. 7—Adjusting Governor Speed

Governor speed is regulated by the position of the speed control bracket (A, Fig. 7). The bracket (A) acts as a stop, limiting the rotation of the speed control disk (C).

Start engine and check engine speed at full throttle. Move speed control bracket (A) as required until maximum engine speed is 3500 rpm on tachometer with all drives disconnected.

Governor arm (B) must operate freely. If bushing adjustment is necessary, see Fig. 5 on page 30-10-4.

210, 212 and 214 Tractors

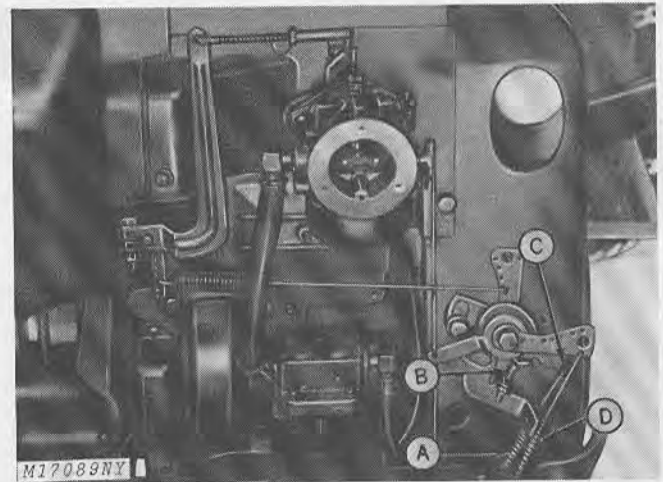

A—Throttle Cable C—Throttle Control Lever
B—Adjusting Screw D—Clamp

Fig. 8—Adjusting Governor Speed

To adjust governor speed, disconnect throttle cable (A, Fig. 8) from throttle control lever (C). Start engine and move throttle control lever (C) toward adjusting screw (B) until engine speed is 3500 rpm on tachometer with all drives disconnected. Turning adjusting screw (B) in increases engine speed and turning it out decreases engine speed.

Move control lever on dash panel to fast position. Loosen clamp (D) holding throttle and choke cables. Connect throttle cable (A) to control lever (C). Move cable until control lever (C) just contacts adjusting screw (B). Tighten clamp securely.

Carburetor Adjustment

Idle adjustment and high-speed adjustment must be made at the same time as each affects the other. Adjust as follows:

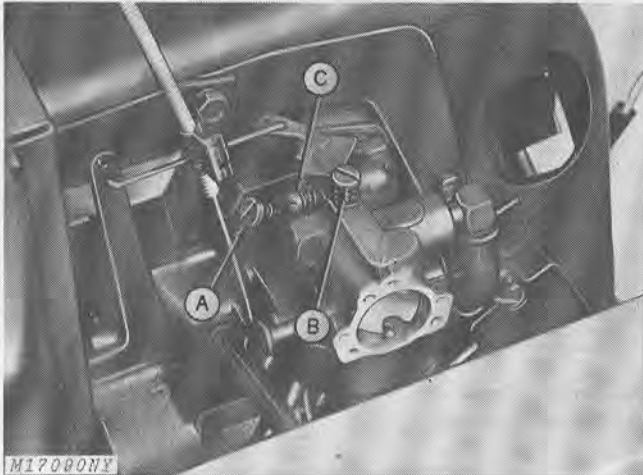

A—Idle Mixture Needle
B—High-Speed Mixture Needle
C—Idle Stop Screw

Fig. 9—Carburetor Adjustment—200 Tractor

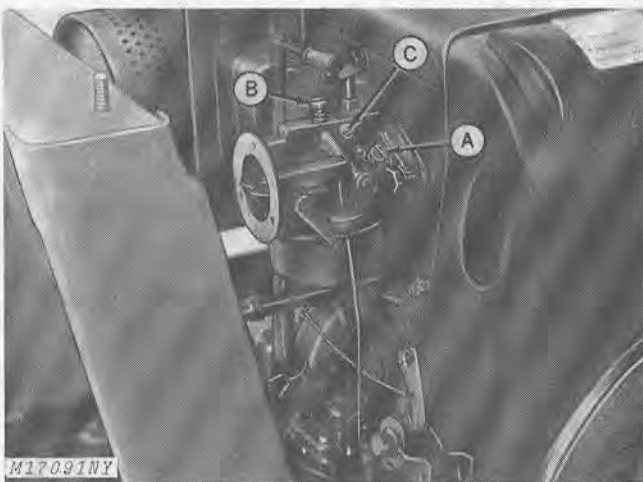

A—Idle Mixture Needle
B—High-Speed Mixture Needle
C—Idle Stop Screw

Fig. 10—Carburetor Adjustment—210, 212 and 214 Tractors

1. Carefully seat both mixture needles, Figs. 9 and 10; then, back off high-speed needle (B) 2 turns and idle mixture needle (A) 2-1/2 turns. Start engine and allow it to warm up.

2. Raise throttle control on dash panel to fast position. Turn high-speed mixture needle (B) 1/8

turn each time, clockwise or counterclockwise until engine runs smoothly.

NOTE: High-speed needle (B) should be slightly on the rich side (open) when operating tractor with power-driven equipment such as mower or snow thrower.

3. Move throttle lever to "slow" position and turn idle mixture needle (A) 1/8 turn each time, clockwise or counterclockwise until engine runs smoothly.

4. Set idle stop screw (C) so engine idles at 1700 to 1900 rpm on a tachometer. Readjust idle mixture needle if necessary.

5. Advance throttle lever quickly to "fast" position to check for uniform acceleration. If engine misses, fuel-air mixture may be too lean. Turn high-speed mixture needle counterclockwise until positive acceleration can be obtained.

Float Damper Spring

NOTE: When tractors are driven over exceptionally rough ground, bobbing of the carburetor float allows excessive fuel into the carburetor which results in engine flooding. To prevent this condition, install a carburetor float damper spring (M47422).

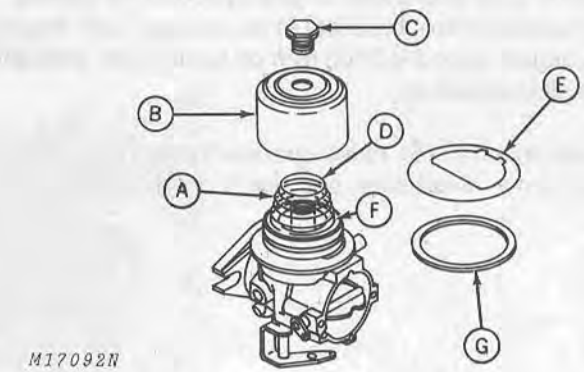

M17092N

A—Damper Spring
B—Bowl
C—Bowl Retaining Screw
D—Small End
E—Baffle Gasket
F—Float
G—Bowl Ring Gasket

Fig. 11—Installing Float Damper Spring

Remove the carburetor from the engine. Then turn it upside down as shown in Fig. 11. Remove the bowl (B), baffle gasket (E) and bowl ring gasket (G). Check float level and adjust if needed. See page 30-10-3. Reinstall bowl ring gasket (G) and new baffle gasket (E). Place damper spring (A) on the float as shown and reinstall carburetor bowl (B).

ASSEMBLY

Install the carburetor repair kit whenever the carburetor is disassembled for service. The kit consists of items marked with an asterisk in Fig. 2.

Installing Float Valve

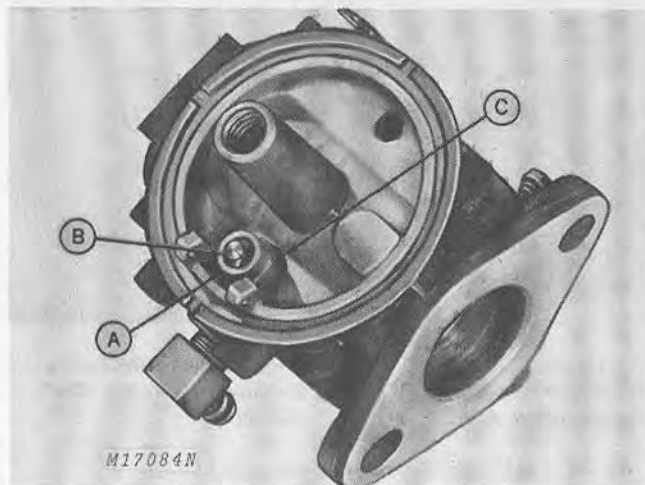

A—Valve Seat B—Valve C—Fiber Gasket

Fig. 3-Installing Float Valve Seat and Valve

The valve seat (A), valve (B) and fiber gasket (C, Fig. 3), are packaged together for service. Never replace one part without replacing the other parts.

Screw valve seat assembly (A), with gaskets, into carburetor housing. Tighten securely. Insert valve (B) with tapered end against valve seat.

Installing Float and Fuel Bowl

Assemble float (L, Fig. 2) to carburetor housing with float pin (P, Fig. 2). Invert carburetor, Fig. 4. With float (A, Fig. 4) resting lightly on float valve, the distance between float and machined surface of carburetor body should be $11/64$ -inch \pm $1/32$ -inch (4.366 ± 0.79 mm) (B). To increase or decrease the distance, bend lip on float. Dimension should be made on free end of float (opposite valve seat), Fig. 4.

Install bowl ring gasket (J, Fig. 2) in groove of carburetor body.

Position bowl gasket (K, Fig. 2), fuel bowl (M, Fig. 2), bowl screw gasket (N, Fig. 2), and bowl screw (O, Fig. 2). Tighten screw firmly, being certain bowl is centered on gasket.

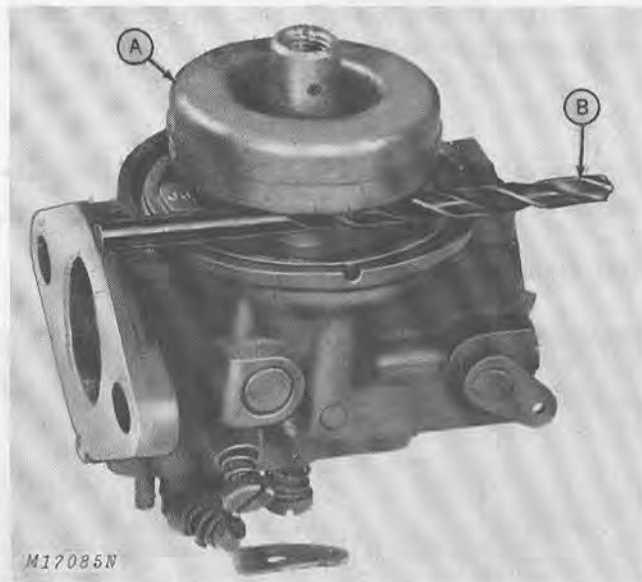

A—Float
B— $11/64$ Inch (4.366 mm) Drill Bit

Fig. 4-Adjusting Float

Install idle mixture needle (G, Fig. 2) through spring (H, Fig. 2) and high-speed mixture needle (A, Fig. 2) into carburetor body.

Carefully turn mixture needles clockwise until lightly seated. Back out high-speed mixture needle 2 turns and idle mixture needle 2-1/2 turns. These are preliminary adjustments only.

NOTE: Do not tighten mixture needles too firmly against seats or damage will result.

INSTALLATION

Place new gasket between carburetor flange and cylinder block. Install carburetor and tighten nuts. Connect throttle linkage to throttle arm. Attach choke control cable to choke plate and connect fuel line.

Secure choke conduit clamps to supporting bracket. Be sure choke plate opens completely when choke control on dash panel is in.

ADJUSTMENT

Governor-to-Carburetor Linkage Adjustment

200 Tractor

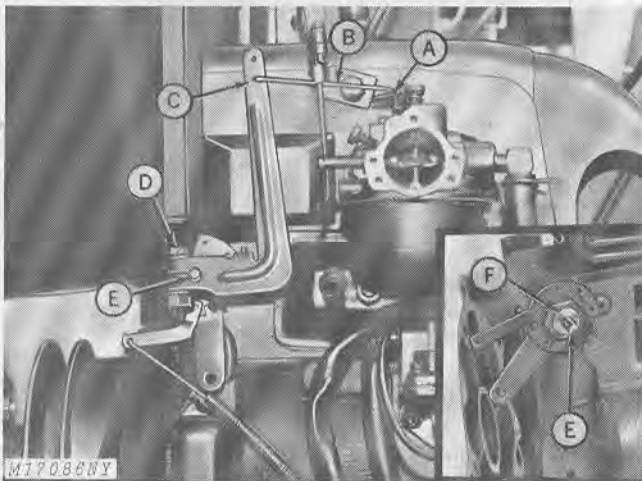

- | | |
|--------------------|------------------------|
| A—Throttle Arm | D—Governor Arm Bolt |
| B—Governor Linkage | E—Governor Cross Shaft |
| C—Governor Arm | F—Bushing Nut |

Fig. 5-Adjusting Governor-to-Carburetor Linkage

Connect governor linkage (B, Fig. 5) in bottom hole of governor arm (C) and in hole closest to throttle shaft in throttle arm (A).

Loosen governor arm bolt (D). Turn governor cross shaft (E) counterclockwise as far as possible. Hold cross shaft (E) in this position and move governor arm (C) to the left (away from carburetor) and tighten governor arm bolt (D). Move governor arm (C) through its full arc of travel to be sure it operates freely.

NOTE: Relieve pressure on bushing nut (F) if arm does not move freely.

210, 212 and 214 Tractors

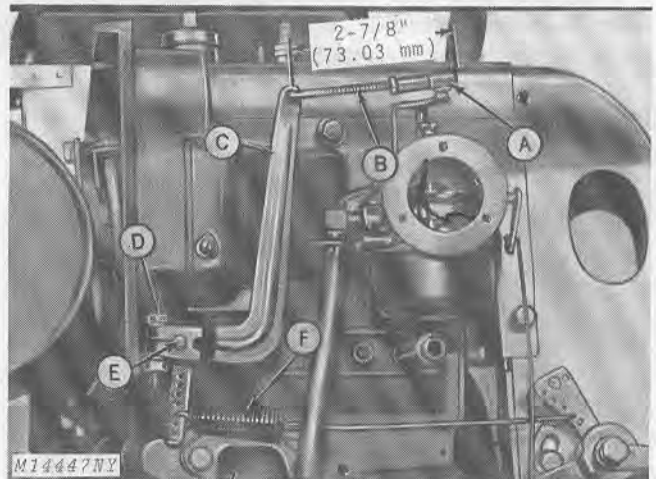

- | | |
|-------------------|------------------------|
| A—Throttle Lever | D—Governor Arm Bolt |
| B—Adjustable Link | E—Governor Cross Shaft |
| C—Governor Arm | F—Spring |

Fig. 6-Governor-to-Carburetor Linkage

Install adjustable link (B, Fig. 6). Be sure the link is 2-7/8 inches (73.03 mm) long. To adjust, snap link (B) off throttle lever (A). Loosen lock nut and turn end on or off link (B) to obtain correct length. Tighten lock nut and snap link (B) on throttle lever (A).

Loosen governor arm bolt (D). Turn governor cross shaft (E) counterclockwise as far as possible. Hold cross shaft (E) in this position and move governor arm (C) to the left (away from carburetor) and tighten governor arm bolt (D). Move governor arm (C) through its full arc of travel to be sure it operates freely.

NOTE: Bushing nut (F, Fig. 5) on governor cross shaft is NOT used on 210, 212 and 214 Tractors. If looseness is noticed in the throttle linkage, readjust adjustable link (B, Fig. 6).

Install the spring (F) as shown in Fig. 6. Governor sensitivity is controlled by spring (F). Raising the spring in the holes, reduces sensitivity and lowering the spring increases sensitivity.

NOTE: If governor is set too sensitive, speed surging will occur with load change. If a big drop in speed occurs when normal load is applied, the governor should be set for greater sensitivity.

Group 15 AIR CLEANER

GENERAL INFORMATION

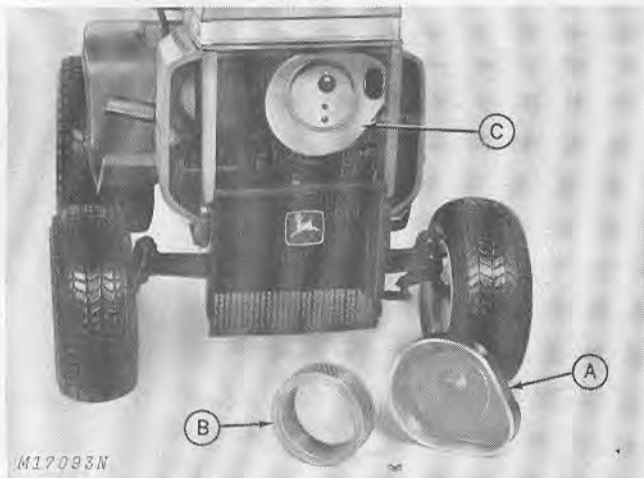

A—Cover B—Air Filter Element C—Base

Fig. 1—Air Cleaner

The air cleaner consists of the base (C) mounted on the carburetor, an air filter element (B) and a cover (A) that fits over the filter element, Fig. 1. The filter element is made of treated paper with a soft sealing edge.

Care of the air cleaner is important since all the air that enters the engine goes through the air filter element. A clogged air filter element restricts air flow and reduces engine efficiency. A damaged air filter element allows dirt to enter the engine and causes immediate damage to internal working parts.

SERVICING AIR CLEANER

The most damaging engine wear can be traced to entry of dirt or dust through an improperly serviced air filter element.

Cleaning

Under normal conditions the air filter element should be cleaned every 25 hours of operation. However, under extremely dusty conditions, it should be cleaned every 5 hours of operation.

Tap the filter lightly against a flat surface and brush out dust. Do not clean filter with a liquid cleaner or compressed air.

Replace filter if it is bent, crushed, damaged or extremely dirty. Under extremely dusty conditions, replace filter every 100 hours of operation. When in doubt, replace filter.

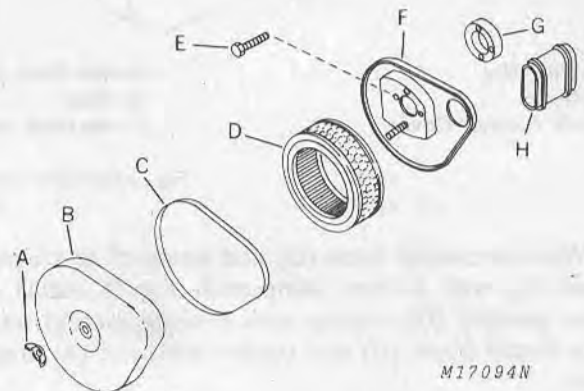

A—Wing Nut E—Cap Screw
B—Air Cleaner Cover F—Air Cleaner Base
C—Seal G—Gasket
D—Air Filter Element H—Tube

Fig. 2—Exploded View of Air Cleaner Components
(210, 212 and 214 Tractors)

Wipe air cleaner base (F) and inside of air cleaner cover (B) with a clean damp cloth, Fig. 2. Install air filter element (D) making sure it seats around base (F). Install cover (B) and tighten wing nut (A) finger tight.

IMPORTANT: Never run engine with air filter element removed.

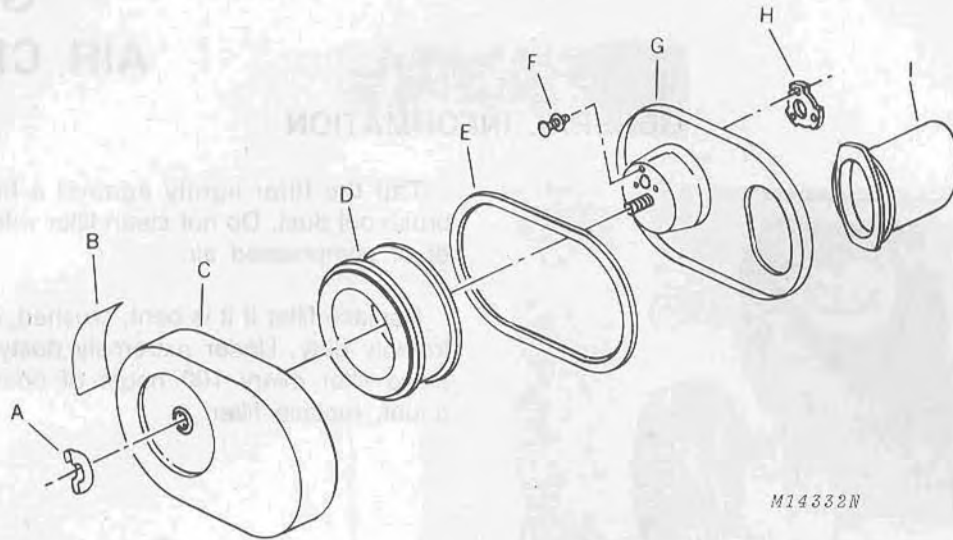

M14332N

A—Wing Nut
B—Decal
C—Air Cleaner Cover

D—Air Filter Element
E—Seal
F—Machine Screw

G—Air Cleaner Base
H—Gasket
I—Tube

Fig. 3-Exploded View of Air Cleaner Components
(200 Tractor)

Wipe air cleaner base (G) and inside of air cleaner cover (C) with a clean damp cloth, Fig. 3. Install air filter element (D) making sure it seats around base (G). Install cover (C) and tighten wing nut (A) finger tight.

Group 20 FUEL STRAINER AND FUEL TANK

FUEL STRAINER

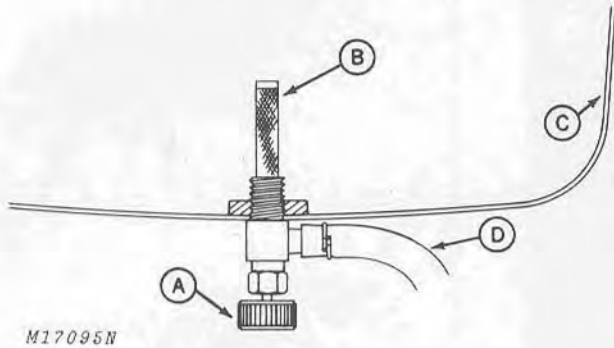

A—Fuel Shut-Off Valve
B—In-Line Strainer
C—Fuel Tank
D—Hose to Fuel Pump

Fig. 1—In-Line Fuel Strainer

The in-line fuel strainer (B, Fig. 1) is used to prevent foreign particles from entering the carburetor. Should the strainer (B) become plugged, it can be removed for cleaning as follows:

Shut off fuel by turning thumb screw on fuel shut-off valve (A) clockwise. Remove fuel line (D) from fuel pump, open fuel shut-off valve (A) and drain fuel tank.

⚠ CAUTION: Gasoline is dangerous. When draining or filling fuel tank avoid fires due to smoking or careless maintenance practices.

Unscrew fuel shut-off valve (A) and strainer assembly (B) from tank. Clean strainer with gasoline and compressed air. Replace in tank. Fill tank with gasoline. Open fuel shut-off valve (A) and bleed air from fuel line (D). Attach fuel line (D) to fuel pump.

FUEL TANK

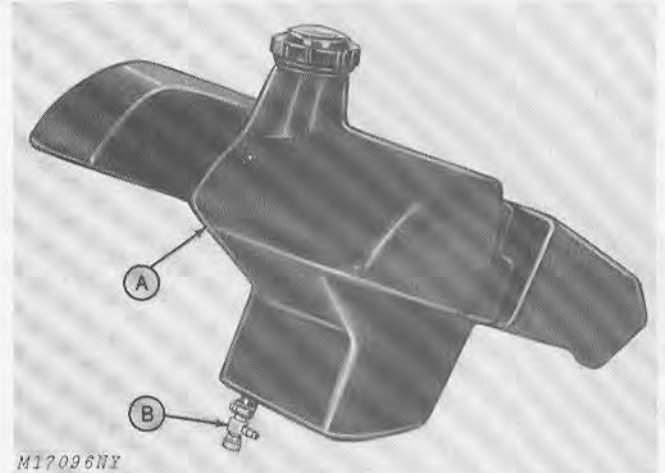

A—Fuel Tank
B—Fuel Shut-Off Valve

Fig. 2—Fuel Tank

Clean fuel tank (A, Fig. 2) and fuel strainer (B, Fig. 1) whenever gum deposits are detected in the tank or when dirty fuel has been used.

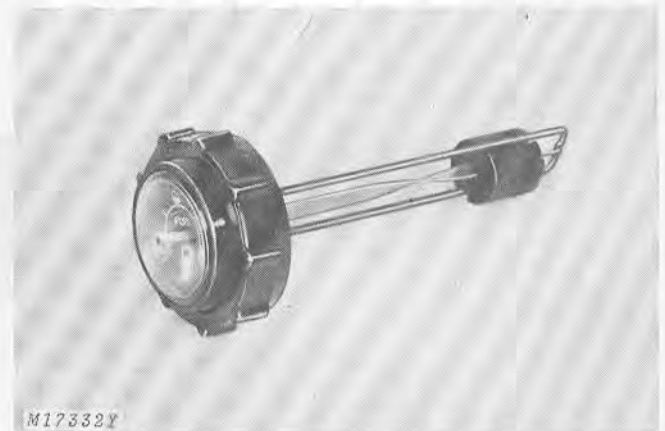

Fig. 3—Fuel Gauge

The fuel gauge is located in the fuel tank cap. A float riding on a twisted shaft operates the gauge indicator.

Group 20

FUEL STRAINER AND FUEL TANK

FUEL TANK



A-Fuel Tank

B-Fuel Filter

Clean fuel tank (A, Fig. 2) and fuel strainer (B, Fig. 2) whenever you observe any deposits in the tank or when dirty fuel has been used.



FUEL STRAINER

The fuel gauge is located in the fuel tank cap. A float riding on a switch shaft operates the gauge indicator.

FUEL STRAINER



A-Fuel Tank
 B-Fuel Filter
 C-Fuel Pump
 D-Fuel Pump

The fuel strainer (B, Fig. 1) is used to prevent dirt and debris from entering the fuel system. The strainer (B) becomes plugged if not removed for cleaning as follows:

1. Shut off fuel by turning main valve on fuel shut-off valve (A) clockwise. Remove filter (D) from fuel pump, open fuel shut-off valve (A) and drain fuel tank.

CAUTION: Exercise extreme care when draining or filling fuel tank. Avoid fire or explosion by avoiding all smoking, open flames, sparks, etc.

2. Remove fuel shut-off valve (A) and strainer (B) from fuel tank. Clean tank by using compressed air. Blow out fuel tank with compressed air. Blow out fuel tank with compressed air. Blow out fuel tank with compressed air. Blow out fuel tank with compressed air.

Group 25 FUEL PUMP

FUEL PUMP - KOHLER K181QS ENGINE

GENERAL INFORMATION

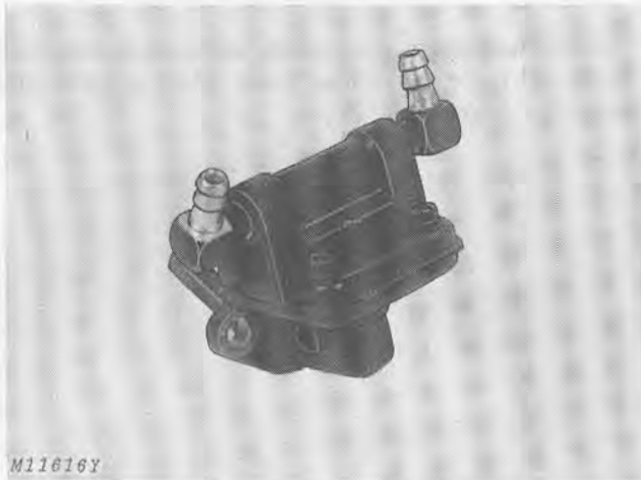

Fig. 1-Fuel Pump

The mechanical fuel pump, Fig. 1, operates off a cam on the camshaft. The actuating lever rides on the cam and transmits this mechanical action to the diaphragm within the pump body.

A repair kit is available for reconditioning the pump. The kit includes the necessary gaskets, seals, and check valve components.

REPAIR

Disconnect fuel lines and remove fuel pump from engine.

Use a file to mark the pump cover (H) and pump body (B) Fig. 2. This will insure correct reassembly of the fuel pump. See (A) Fig. 2.

Remove assembly screws (G) and cover (H). Turn cover over and remove valve retainer screw (J) and washer.

Remove valve retainer (D), valves (E), valve springs (F) and valve gasket (I). Discard valve springs, valves and valve gasket.

Clean pump cover (H) thoroughly with PT503 cleaner or its equivalent.

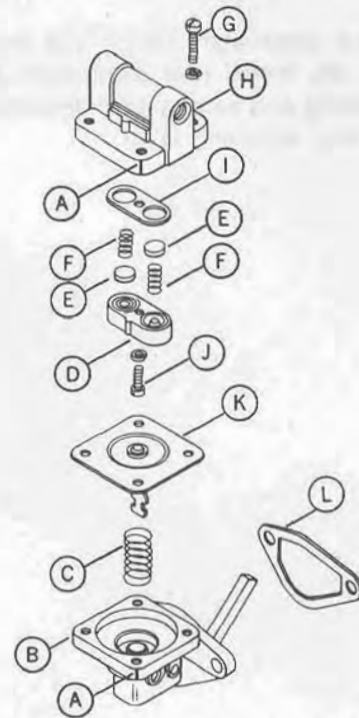

- M17097N
- | | |
|--------------------|------------------------|
| A—File Mark | G—Assembly Screw |
| B—Pump Body | H—Pump Cover |
| C—Diaphragm Spring | I—Valve Gasket |
| D—Valve Retainer | J—Valve Retainer Screw |
| E—Pump Valve | K—Diaphragm |
| F—Valve Spring | L—Mounting Gasket |

Fig. 2-Exploded View of Fuel Pump

Hold pump cover (H) upside-down (diaphragm mounting surface up) and install a new gasket (I) into cavity. Install new valve springs (F) and valves (E) into their respective places.

NOTE: Valve springs and valves are installed opposite to each other, Fig. 2.

Install valve retainer (D) and secure with valve retainer screw (J) and washer.

REPAIR—Continued

To rebuild the lower diaphragm section of the pump, hold the pump body (B, Fig. 2) and press down on the diaphragm (K) to compress diaphragm spring (C). Turn bracket 90 degrees to unhook and remove diaphragm (K). Clean pump body (B) with PT503 cleaner or its equivalent.

Install new diaphragm spring (C) into cavity in pump body (B). Install new diaphragm (K) by positioning, pressing and turning it 90 degrees until it can be hooked into actuating lever.



- 1—Mounting bracket
- 2—Diaphragm
- 3—Diaphragm spring
- 4—Actuating lever
- 5—Fuel pump body
- 6—Fuel pump cover
- 7—Fuel pump gasket
- 8—Fuel pump screws
- 9—Fuel pump cover screws
- 10—Fuel pump cover gasket
- 11—Fuel pump cover mounting bracket
- 12—Fuel pump cover mounting screws
- 13—Fuel pump cover mounting gasket
- 14—Fuel pump cover mounting bracket screws
- 15—Fuel pump cover mounting gasket screws
- 16—Fuel pump cover mounting bracket gasket screws
- 17—Fuel pump cover mounting gasket screws
- 18—Fuel pump cover mounting bracket screws
- 19—Fuel pump cover mounting gasket screws
- 20—Fuel pump cover mounting bracket screws
- 21—Fuel pump cover mounting gasket screws
- 22—Fuel pump cover mounting bracket screws
- 23—Fuel pump cover mounting gasket screws
- 24—Fuel pump cover mounting bracket screws
- 25—Fuel pump cover mounting gasket screws
- 26—Fuel pump cover mounting bracket screws
- 27—Fuel pump cover mounting gasket screws
- 28—Fuel pump cover mounting bracket screws
- 29—Fuel pump cover mounting gasket screws
- 30—Fuel pump cover mounting bracket screws
- 31—Fuel pump cover mounting gasket screws
- 32—Fuel pump cover mounting bracket screws
- 33—Fuel pump cover mounting gasket screws
- 34—Fuel pump cover mounting bracket screws
- 35—Fuel pump cover mounting gasket screws
- 36—Fuel pump cover mounting bracket screws
- 37—Fuel pump cover mounting gasket screws
- 38—Fuel pump cover mounting bracket screws
- 39—Fuel pump cover mounting gasket screws
- 40—Fuel pump cover mounting bracket screws
- 41—Fuel pump cover mounting gasket screws
- 42—Fuel pump cover mounting bracket screws
- 43—Fuel pump cover mounting gasket screws
- 44—Fuel pump cover mounting bracket screws
- 45—Fuel pump cover mounting gasket screws
- 46—Fuel pump cover mounting bracket screws
- 47—Fuel pump cover mounting gasket screws
- 48—Fuel pump cover mounting bracket screws
- 49—Fuel pump cover mounting gasket screws
- 50—Fuel pump cover mounting bracket screws
- 51—Fuel pump cover mounting gasket screws
- 52—Fuel pump cover mounting bracket screws
- 53—Fuel pump cover mounting gasket screws
- 54—Fuel pump cover mounting bracket screws
- 55—Fuel pump cover mounting gasket screws
- 56—Fuel pump cover mounting bracket screws
- 57—Fuel pump cover mounting gasket screws
- 58—Fuel pump cover mounting bracket screws
- 59—Fuel pump cover mounting gasket screws
- 60—Fuel pump cover mounting bracket screws
- 61—Fuel pump cover mounting gasket screws
- 62—Fuel pump cover mounting bracket screws
- 63—Fuel pump cover mounting gasket screws
- 64—Fuel pump cover mounting bracket screws
- 65—Fuel pump cover mounting gasket screws
- 66—Fuel pump cover mounting bracket screws
- 67—Fuel pump cover mounting gasket screws
- 68—Fuel pump cover mounting bracket screws
- 69—Fuel pump cover mounting gasket screws
- 70—Fuel pump cover mounting bracket screws
- 71—Fuel pump cover mounting gasket screws
- 72—Fuel pump cover mounting bracket screws
- 73—Fuel pump cover mounting gasket screws
- 74—Fuel pump cover mounting bracket screws
- 75—Fuel pump cover mounting gasket screws
- 76—Fuel pump cover mounting bracket screws
- 77—Fuel pump cover mounting gasket screws
- 78—Fuel pump cover mounting bracket screws
- 79—Fuel pump cover mounting gasket screws
- 80—Fuel pump cover mounting bracket screws
- 81—Fuel pump cover mounting gasket screws
- 82—Fuel pump cover mounting bracket screws
- 83—Fuel pump cover mounting gasket screws
- 84—Fuel pump cover mounting bracket screws
- 85—Fuel pump cover mounting gasket screws
- 86—Fuel pump cover mounting bracket screws
- 87—Fuel pump cover mounting gasket screws
- 88—Fuel pump cover mounting bracket screws
- 89—Fuel pump cover mounting gasket screws
- 90—Fuel pump cover mounting bracket screws
- 91—Fuel pump cover mounting gasket screws
- 92—Fuel pump cover mounting bracket screws
- 93—Fuel pump cover mounting gasket screws
- 94—Fuel pump cover mounting bracket screws
- 95—Fuel pump cover mounting gasket screws
- 96—Fuel pump cover mounting bracket screws
- 97—Fuel pump cover mounting gasket screws
- 98—Fuel pump cover mounting bracket screws
- 99—Fuel pump cover mounting gasket screws
- 100—Fuel pump cover mounting bracket screws

Hold pump body (B) and install pump cover (H) to body (file marks aligned) with four assembly screws (G). DO NOT TIGHTEN SCREWS AT THIS TIME.

With hand on pump body (B) only (not on cover, H), push the actuating lever to the limit of its travel. Hold actuating lever in this position and tighten the four assembly screws (G). This is important to prevent stretching the diaphragm (K).

Install fuel pump on engine, using new mounting gasket (L). Connect fuel lines. Start engine and check for leaks.

FUEL PUMP - KOHLER K241AQS, K301AQS AND K321AQS ENGINES

PRINCIPLE OF OPERATION

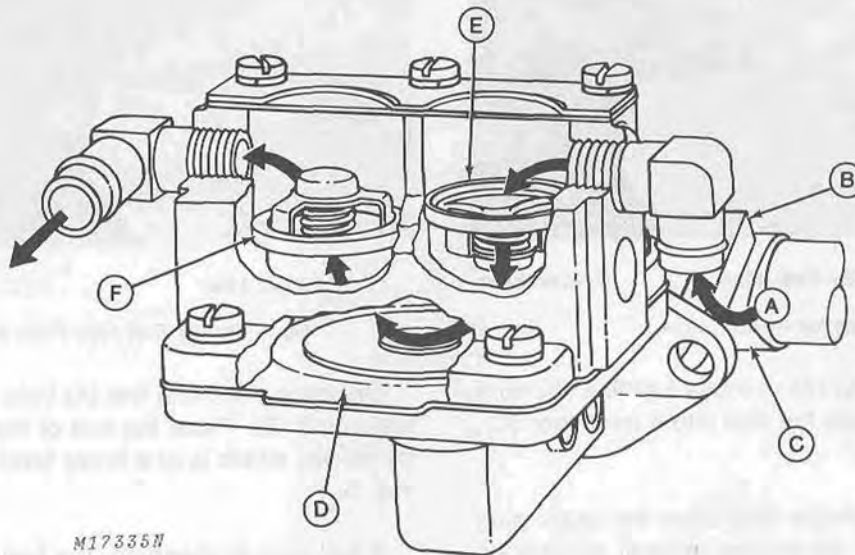

- | | |
|-----------------|----------------------|
| A—Fuel | D—Diaphragm |
| B—Lever | E—Inlet Check Valve |
| C—Camshaft Lobe | F—Outlet Check Valve |

Fig. 3-Fuel Pump Operation

The fuel pump is a mechanically operated diaphragm-type pump.

A lever (B) riding on a lobe of the engine camshaft (C) operates the diaphragm (D) up and down, Fig. 3.

As the diaphragm moves down, a low pressure area is created in the pump. This opens the inlet check valve (E) and closes the outlet check valve (F). Fuel (A) then enters the pump to fill the low pressure area.

As the diaphragm is pushed up, the outlet check valve (F) opens, the inlet check valve (E) closes and fuel is pushed out of the pump to the carburetor.

A repair kit is available for reconditioning the pump. This kit includes the necessary gaskets, diaphragm and check valves.

DIAGNOSIS AND TESTING

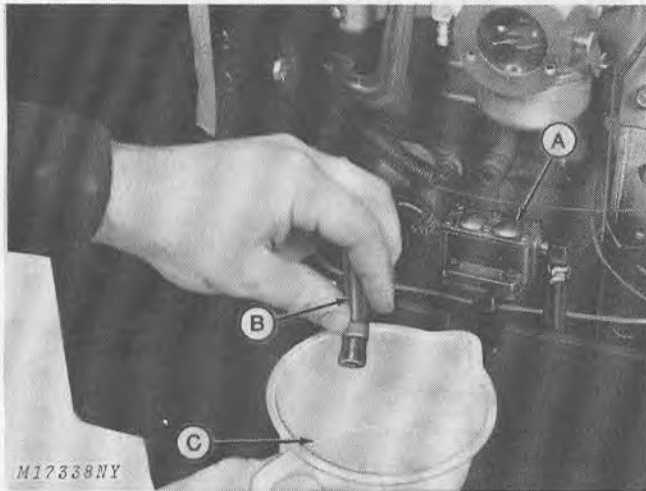

A—Fuel Pump B—Fuel Line C—Container

Fig. 4-Testing Pump Output

To test the fuel pump (A), remove fuel line (B) from the carburetor and place the end into a container (C), Fig. 4.

Remove the high-tension lead from the spark plug and ground it. Crank the engine several revolutions with the starter.

Observe fuel flow into the container. If no flow is observed, proceed to the next test.

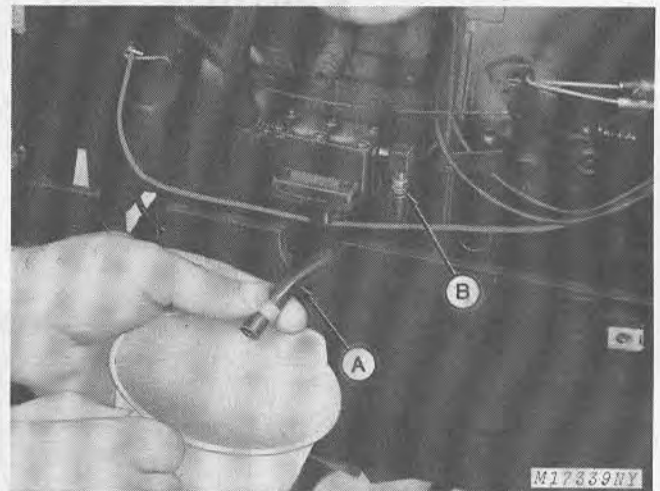

A—Fuel Line B—Fuel Pump

Fig. 5-Testing Fuel Flow From the Fuel Tank

Disconnect the fuel line (A) from the inlet side of the fuel pump (B). Place the end of the fuel line (A) into a container, which is at a lower level than the fuel tank, Fig. 5.

If fuel flow is observed, the fuel pump is defective.

If no flow is observed, check the fuel shut-off at the fuel tank. (Be sure it is open.) Also check for a clogged strainer screen, blocked or pinched fuel line, plugged fuel tank vent in cap and be sure there is fuel in the tank.

DISASSEMBLY AND REPAIR

Removal

Close the shut-off valve at the fuel tank. Remove the fuel lines from the fuel pump. Remove the mounting screws holding the pump to the engine.

Disassembly

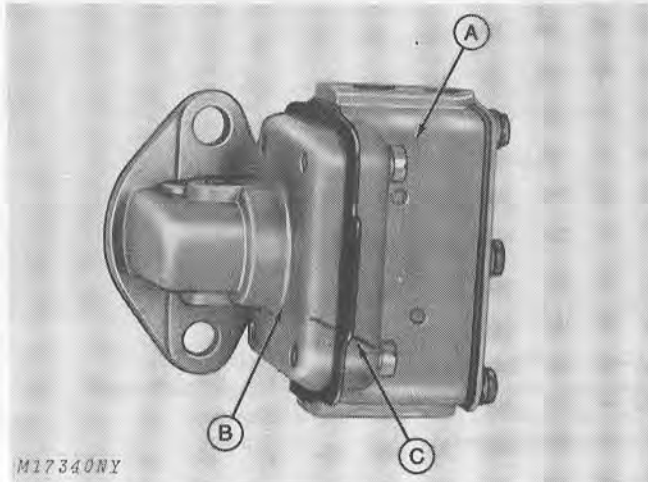

A—Upper Housing B—Lower Housing C—Scribe Line

Fig. 6-Fuel Pump

Before disassembly, scribe a line (C) across the upper housing (A), and lower housing (B), Fig. 6, to assure correct reassembly.

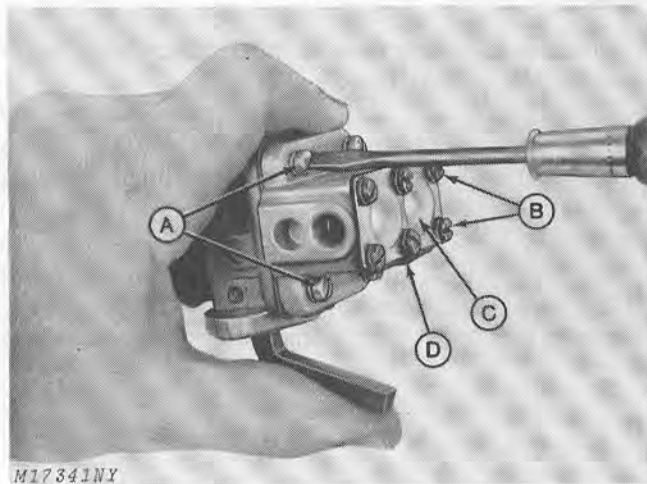

A—Cap Screws B—Screws C—Cover D—Upper Diaphragm

Fig. 7-Disassembling Fuel Pump

Remove four cap screws (A) from the pump housing and separate the upper and lower halves of the pump.

Remove six screws (B) from the pump cover (C). Remove the cover (C) and upper diaphragm (D), Fig. 7.

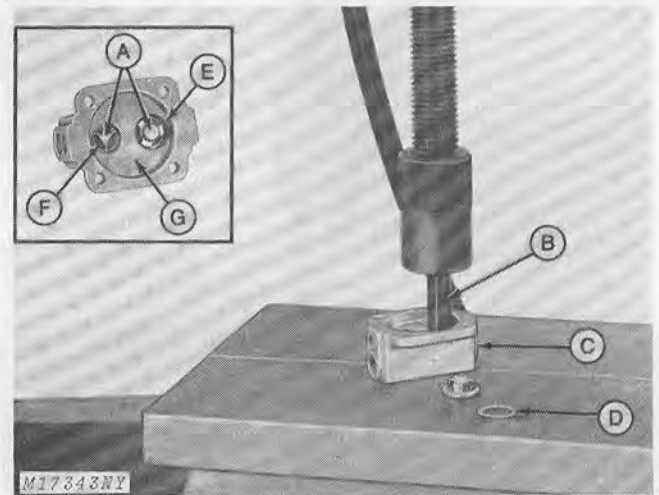

A—Check Valves B—Pilot C—Upper Housing D—Gaskets E—Inlet Port F—Outlet Port G—Fuel Well

Fig. 8-Removing Check Valves

Note the position of both check valves (A) in the fuel pump (facing opposite each other). Check valve at the inlet port (E) faces away from fuel well (G). Check valve at the outlet port (F) faces toward the fuel well (G).

Position the pump in a press and using an appropriate pilot (B), press the check valves from the upper housing (C).

Remove the old check valve gaskets (D), Fig. 8.

NOTE: The check valves will be damaged when removed. New check valves are supplied in the pump repair kit.

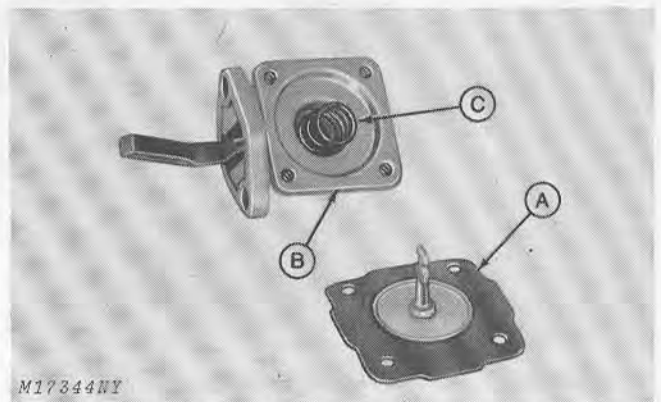

A—Diaphragm B—Lower Housing C—Spring

Fig. 9-Removing Diaphragm

Remove the diaphragm (A) by turning it 90 degrees left or right. Remove diaphragm spring (C) from lower housing (B), Fig. 9.

ASSEMBLY

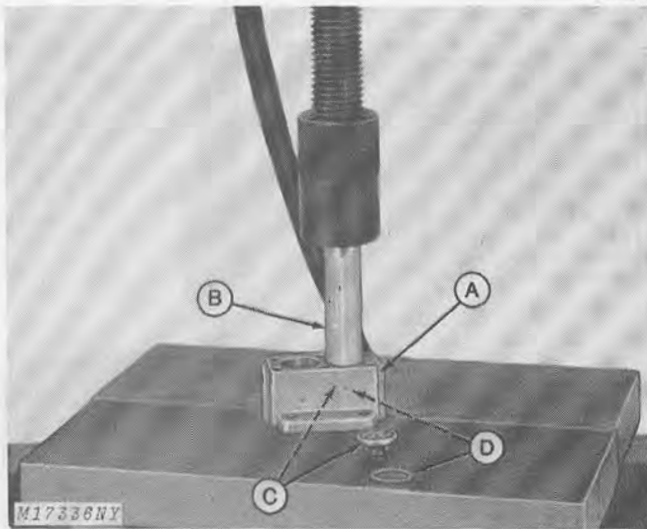

A—Upper Housing
B—1/2-Inch Thin Wall Tubing
C—Check Valves
D—Gaskets

Fig. 10-Pressing New Check Valves into Upper Housing

Place new gaskets (D) in upper housing (A), Fig. 10. Place upper housing on press with large holes facing up. Use a short piece of 1/2-inch thin wall tubing (B) to press new check valves (C) into housing until they bottom against the gaskets.

IMPORTANT: Replace check valves in same position as noted on page 30-25-5, Fig. 8.

NOTE: Press only on the outside edge of the check valves. The 1/2-inch thin wall tubing works well for this purpose.

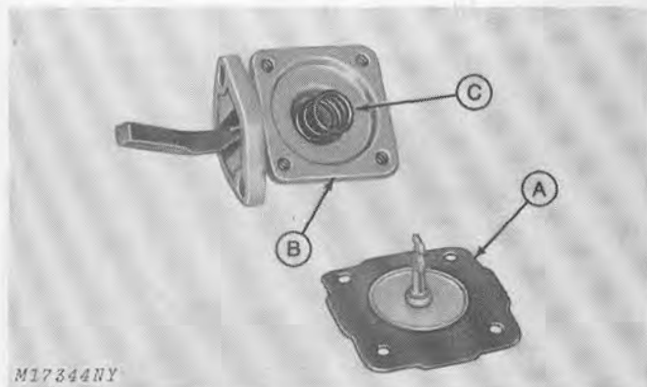

A—Diaphragm
B—Lower Housing
C—Spring

Fig. 11-Installing Diaphragm

Install spring (C) into lower housing (B).

Install diaphragm into lower housing by pushing down on diaphragm and turning it 90 degrees.

Litho in U.S.A.

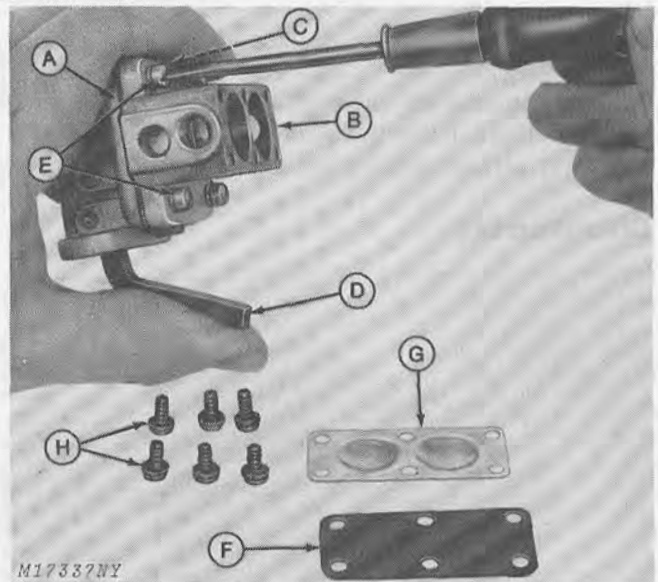

A—Lower Housing
B—Upper Housing
C—Scribe Marks
D—Actuating Lever
E—Cap Screws
F—Upper Diaphragm
G—Cover
H—Screws

Fig. 12-Assembling Pump

Hold pump lower housing (A). Attach upper housing (B) to the lower housing aligning scribe marks (C). (DO NOT TIGHTEN.)

With hand on lower housing, push the actuating lever (D) up to the limit of its travel.

Hold the actuating lever in this position while tightening the four cap screws (E).

This will prevent stretching the diaphragm. Attach upper diaphragm (F) and cover (G) to pump housing using the six screws (H).

Mount the fuel pump on engine (note "IN" and "OUT" marked on pump) using new flange gasket. Connect fuel lines. Start engine and check for leaks.

Group 30 SPECIFICATIONS

SPECIFICATIONS

Item	Dimension	Page Reference
Float Setting	11/64-inch \pm 1/32-inch (4.366 mm \pm 0.794 mm)	30-10-3
Speeds:		
Idle (No load)	1700 to 1900 rpm	30-10-6
High-Speed (No load)	3400 to 3500 rpm	30-10-5
Mixture Needles: (Preliminary Adjustments)		
Idle mixture needle	2 turns	30-10-6
High-speed mixture needle	2-1/2 turns	30-10-6

Group 30
SPECIFICATIONS

Specifications

Item	Specification	Item	Specification
1-01-02	1700-1800 mm	1-01-03	1700 to 2500 mm
1-01-04	1700 to 2500 mm	1-01-05	1700 to 2500 mm
1-01-06	1700 to 2500 mm	1-01-07	1700 to 2500 mm
1-01-08	1700 to 2500 mm	1-01-09	1700 to 2500 mm
1-01-10	1700 to 2500 mm	1-01-11	1700 to 2500 mm
1-01-12	1700 to 2500 mm	1-01-13	1700 to 2500 mm
1-01-14	1700 to 2500 mm	1-01-15	1700 to 2500 mm
1-01-16	1700 to 2500 mm	1-01-17	1700 to 2500 mm
1-01-18	1700 to 2500 mm	1-01-19	1700 to 2500 mm
1-01-20	1700 to 2500 mm	1-01-21	1700 to 2500 mm
1-01-22	1700 to 2500 mm	1-01-23	1700 to 2500 mm
1-01-24	1700 to 2500 mm	1-01-25	1700 to 2500 mm
1-01-26	1700 to 2500 mm	1-01-27	1700 to 2500 mm
1-01-28	1700 to 2500 mm	1-01-29	1700 to 2500 mm
1-01-30	1700 to 2500 mm	1-01-31	1700 to 2500 mm
1-01-32	1700 to 2500 mm	1-01-33	1700 to 2500 mm
1-01-34	1700 to 2500 mm	1-01-35	1700 to 2500 mm
1-01-36	1700 to 2500 mm	1-01-37	1700 to 2500 mm
1-01-38	1700 to 2500 mm	1-01-39	1700 to 2500 mm
1-01-40	1700 to 2500 mm	1-01-41	1700 to 2500 mm
1-01-42	1700 to 2500 mm	1-01-43	1700 to 2500 mm
1-01-44	1700 to 2500 mm	1-01-45	1700 to 2500 mm
1-01-46	1700 to 2500 mm	1-01-47	1700 to 2500 mm
1-01-48	1700 to 2500 mm	1-01-49	1700 to 2500 mm
1-01-50	1700 to 2500 mm	1-01-51	1700 to 2500 mm
1-01-52	1700 to 2500 mm	1-01-53	1700 to 2500 mm
1-01-54	1700 to 2500 mm	1-01-55	1700 to 2500 mm
1-01-56	1700 to 2500 mm	1-01-57	1700 to 2500 mm
1-01-58	1700 to 2500 mm	1-01-59	1700 to 2500 mm
1-01-60	1700 to 2500 mm	1-01-61	1700 to 2500 mm
1-01-62	1700 to 2500 mm	1-01-63	1700 to 2500 mm
1-01-64	1700 to 2500 mm	1-01-65	1700 to 2500 mm
1-01-66	1700 to 2500 mm	1-01-67	1700 to 2500 mm
1-01-68	1700 to 2500 mm	1-01-69	1700 to 2500 mm
1-01-70	1700 to 2500 mm	1-01-71	1700 to 2500 mm
1-01-72	1700 to 2500 mm	1-01-73	1700 to 2500 mm
1-01-74	1700 to 2500 mm	1-01-75	1700 to 2500 mm
1-01-76	1700 to 2500 mm	1-01-77	1700 to 2500 mm
1-01-78	1700 to 2500 mm	1-01-79	1700 to 2500 mm
1-01-80	1700 to 2500 mm	1-01-81	1700 to 2500 mm
1-01-82	1700 to 2500 mm	1-01-83	1700 to 2500 mm
1-01-84	1700 to 2500 mm	1-01-85	1700 to 2500 mm
1-01-86	1700 to 2500 mm	1-01-87	1700 to 2500 mm
1-01-88	1700 to 2500 mm	1-01-89	1700 to 2500 mm
1-01-90	1700 to 2500 mm	1-01-91	1700 to 2500 mm
1-01-92	1700 to 2500 mm	1-01-93	1700 to 2500 mm
1-01-94	1700 to 2500 mm	1-01-95	1700 to 2500 mm
1-01-96	1700 to 2500 mm	1-01-97	1700 to 2500 mm
1-01-98	1700 to 2500 mm	1-01-99	1700 to 2500 mm
1-01-100	1700 to 2500 mm	1-01-101	1700 to 2500 mm

✓

Section 40

ELECTRICAL SYSTEM

Group 5

GENERAL INFORMATION

CONTENTS

	Page		Page
GROUP 5 - GENERAL INFORMATION		GROUP 20 - CHARGING SYSTEM	
Wiring Diagram	5-2	Principle of Operation	20-1
Description	5-2	Alternator	20-1
GROUP 10 - CRANKING SYSTEM		Rectifier-Regulator	20-2
Principle of Operation	10-1	Diagnosing and Testing	20-2
Battery	10-1	Charging System Tests	20-3
Ignition Switch	10-2	Repair	20-4
Solenoid	10-2	Alternator-Stator	20-4
Starter	10-3	GROUP 25 - LIGHTS	
Diagnosing and Testing	10-4	Description	25-1
Cranking System Tests	10-4	Diagnosing Malfunctions	25-1
Battery	10-5	Testing	25-2
Ignition Switch	10-6	Wiring Harness	25-2
Neutral-Start Safety Switches	10-6	Switches	25-2
Solenoid	10-7	GROUP 30 - ELECTRIC LIFT	
Starter	10-7	Principle of Operation	30-1
Armature	10-7	Circuits	30-2
Repair	10-8	Diagnosing and Testing	30-3
Battery	10-8	Adjustments	30-6
Starter	10-10	Depth Control	30-6
GROUP 15 - IGNITION SYSTEM		Stop Spacer	30-6
Principle of Operation	15-1	Lift Lever Tension	30-7
Ignition Switch	15-2	Cam and Control Switch Adjustment	30-7
Spark Plug	15-2	Cam	30-7
Breaker Points	15-2	Control Switches	30-8
Condenser	15-3	Disassembly and Repair	30-9
Coil	15-3	Removing Actuator Assembly	30-9
Diagnosis and Testing	15-4	Removing Electric Motor	30-9
Make a Visual Test of		Removing Gear Box	30-10
Components and Wiring	15-4	Removing Cover Tube and Actuator	30-10
Test Spark Plug	15-4	Assembly	30-11
Test Safety Switches	15-5	Assembling Cover Tube and Actuator	30-11
PTO Safety Switch	15-5	Assembling Motor to Gear Box	30-12
Seat Safety Switch (70,001-)	15-5	Installation	30-13
Test Ignition Switch	15-6		
Adjust Breaker Points	15-6		
Replace Breaker Points	15-7		
Time Engine	15-7		
Test Condenser	15-9		
Test Coil	15-9		
Specifications	15-10		

WIRING DIAGRAM

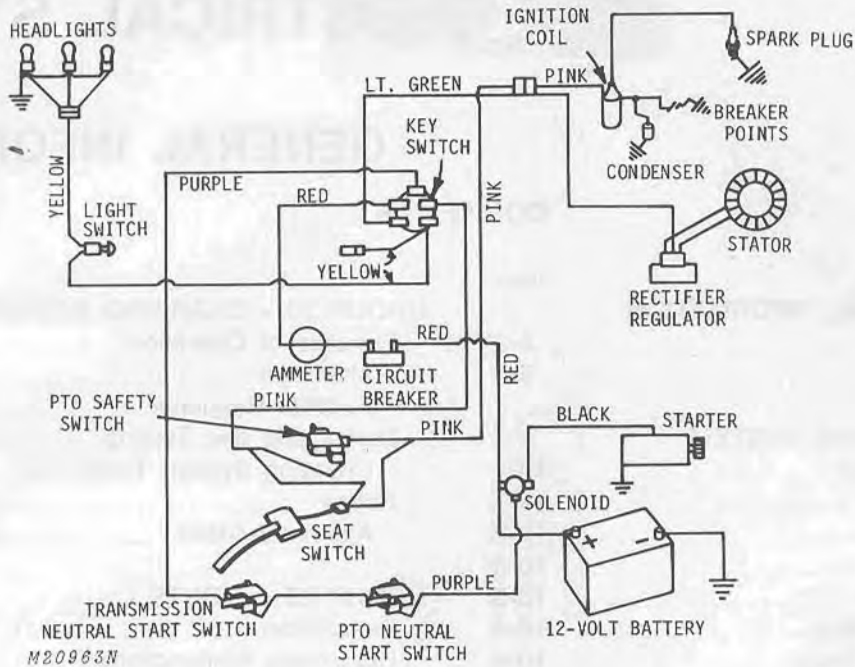

Figure 1-Wiring Diagram

DESCRIPTION

The 200 Series Tractors all have a 12-volt electrical system. The electrical system consists of the cranking, ignition and charging systems, plus the accessory circuit.

The cranking system consists of a battery, solenoid, circuit breaker, key switch, two neutral-start safety switches and a permanent magnet starter motor. See Group 10 for detailed information.

All 200 Series Tractors are equipped with a battery-coil ignition system consisting of a battery, ignition switch, two safety interlock switches, ignition coil, breaker points and condenser. See Group 15 for additional information.

The battery is charged with a 15-amp alternator. A solid-state rectifier-regulator converts AC current from the alternator into DC current and also controls the rate of charging current to the battery. See Group 20 for further information.

A new electric lift is available for 200 Series Tractors. The electric lift is position-responsive in that it reacts directly to control lever movement. Detailed information can be found in Group 30.

Group 10 CRANKING SYSTEM

PRINCIPLE OF OPERATION

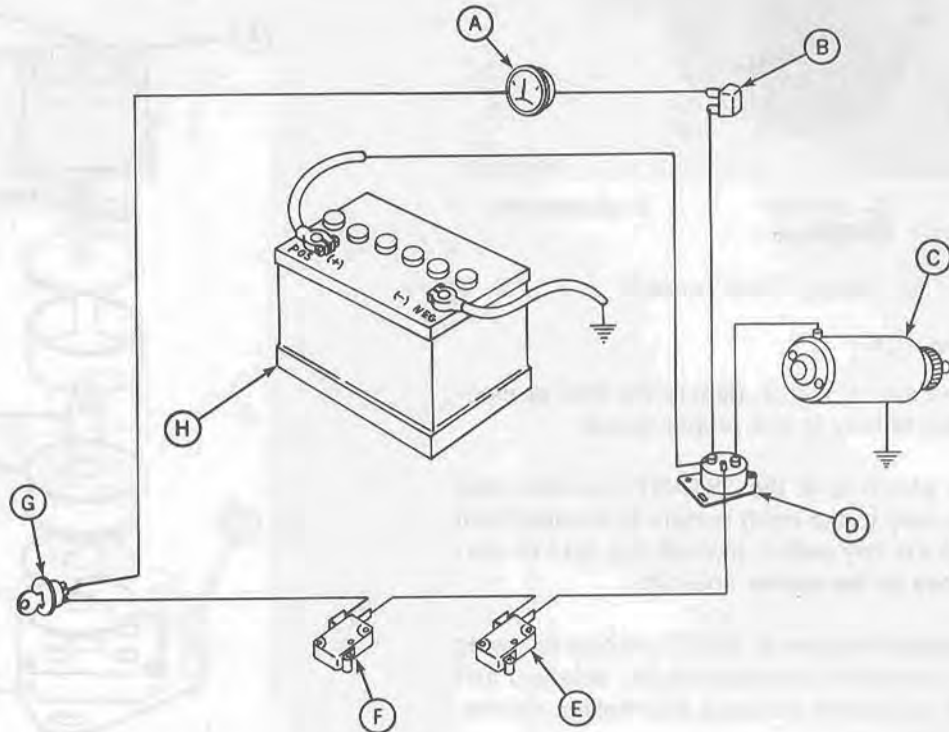

M16798N

- | | | | |
|-------------------|------------|--|--------------|
| A—Ammeter | C—Starter | E—PTO Neutral-Start Safety Switch | G—Key Switch |
| B—Circuit Breaker | D—Solenoid | F—Transmission Neutral-Start Safety Switch | H—Battery |

Fig. 1-Cranking System Components

The cranking system on the 200 Series Tractors consists of a 12-volt battery (H), solenoid (D), circuit breaker (B), ammeter (A), key switch (G), two neutral-start safety switches (E and F), and a permanent magnet starter motor (C).

The two neutral-start safety switches must be closed before the solenoid will activate the starting motor.

Battery

The storage battery is of the lead-acid variety. Lead is used in the construction of the cell plates and a sulfuric acid solution serves as the electrolyte.

Tractors are shipped from the factory with dry-charged batteries. This means the plates are charged, but electrolyte must be added just before using.

The 12-volt battery has a hard rubber case with six individual cells. Each cell contains a specific number of sets of negative and positive plates.

All plates of like charge are interconnected so that the accumulative charges are present at the positive and negative battery terminals.

As a battery discharges and the energy is not replenished, the sulfuric acid is withdrawn from the electrolyte and the lead sulfate deposits build up on the plates. This causes the specific gravity of the electrolyte to diminish. Charging the battery reverses the chemical reaction, restoring the electrolyte to original potential.

IMPORTANT: Avoid battery damage by charging at the manufacturer's recommended ampere-hour charging rate.

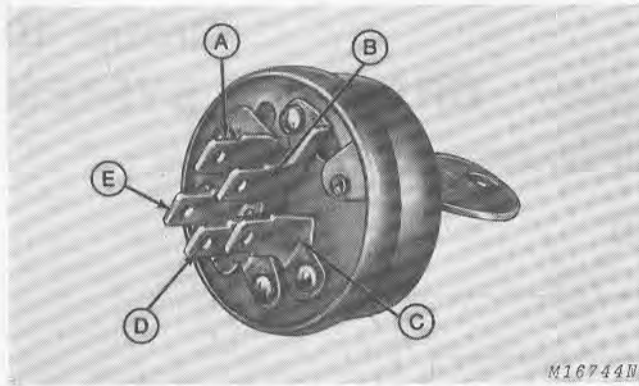

A—Regulator
 B—Battery
 C—Solenoid
 D—Ignition
 E—Accessories

Fig. 2-Ignition Switch Terminals

Ignition Switch

The ignition switch Fig. 2, directs the flow of electricity from the battery to the proper circuit.

When the switch is in the "START" position (key turned all the way to the right) current is directed from the battery to the key switch, through the neutral-start safety switches to the starter solenoid.

When the switch returns to "RUN" position following engine start, current is diverted from the solenoid and routed to the accessory, charging and ignition circuits.

Solenoid

The solenoid, Fig. 3, is an electric switch composed of an electromagnet (A) and spring-loaded plunger (B).

One large terminal (D) is connected to the positive terminal of the battery and the other terminal (E) is connected to the starter. The solenoid base (G) is grounded to the frame, as is the negative post of the battery. When the ignition switch is turned to the "START" position, current flows through the solenoid windings forming a complete circuit with the grounded base and setting up an electromagnetic field.

This draws the plunger into the center of the field, overcoming a spring. A contact (C) at the end of the plunger closes the circuit across the battery and starter contact points permitting current flow from the battery to the starter.

Once the key switch is permitted to return to the "RUN" position, current is cut off from the solenoid collapsing the electromagnetic field. The spring-loaded plunger moves away from the contact point breaking the circuit from the battery to the starter.

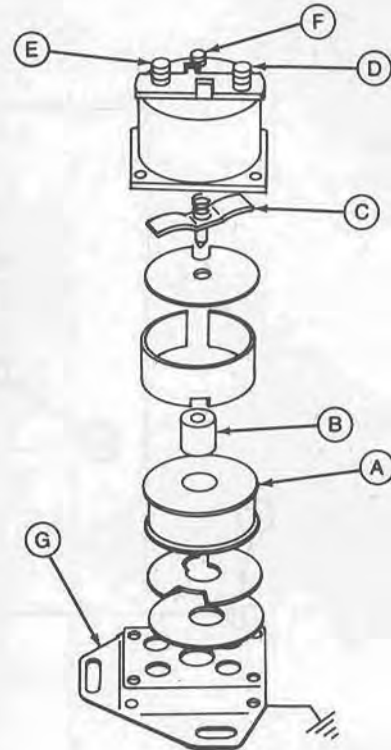

M20964N

A—Electromagnet
 B—Plunger
 C—Contact Points
 D—Positive Battery Terminal
 E—Starter Terminal
 F—Ignition Switch Terminal
 G—Base

Fig. 3-Solenoid Assembly.

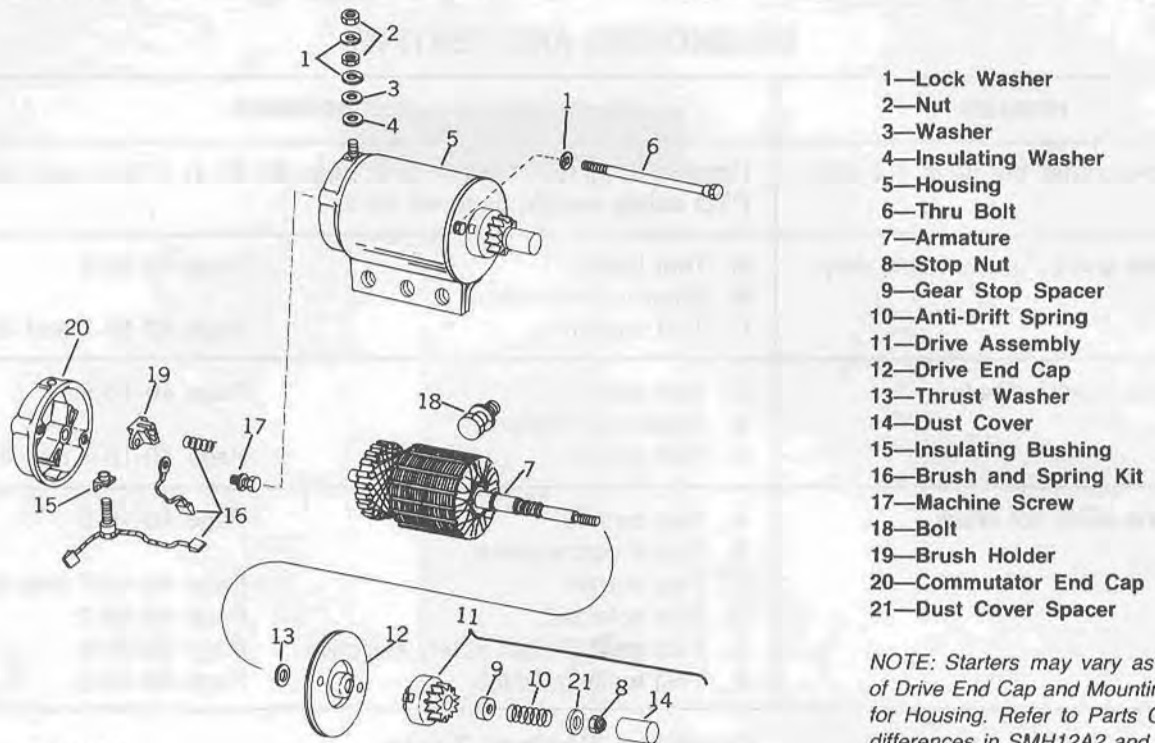

M11827

- 1—Lock Washer
- 2—Nut
- 3—Washer
- 4—Insulating Washer
- 5—Housing
- 6—Thru Bolt
- 7—Armature
- 8—Stop Nut
- 9—Gear Stop Spacer
- 10—Anti-Drift Spring
- 11—Drive Assembly
- 12—Drive End Cap
- 13—Thrust Washer
- 14—Dust Cover
- 15—Insulating Bushing
- 16—Brush and Spring Kit
- 17—Machine Screw
- 18—Bolt
- 19—Brush Holder
- 20—Commutator End Cap
- 21—Dust Cover Spacer

NOTE: Starters may vary as to design of Drive End Cap and Mounting Bracket for Housing. Refer to Parts Catalog for differences in SMH12A2 and SMH12A4 Starters. SMH12A4 shown.

Fig. 4-Exploded View of Starter

Starter

The permanent magnet starter, Fig. 4, differs from wire-wound starter in construction, current requirement and torque characteristics.

On wire-wound starters, a relatively heavy current is directed through field coils and armature to build up a strong magnetic field necessary to start the armature turning.

The permanent magnet starter needs current only for the armature in order to set up opposing magnetic fields to start it turning.

The starter drive consists of the starter drive gear and spring which are mounted on the armature shaft. When the armature turns, the drive gear moves laterally into mesh with the flywheel. As the engine starts and speeds up, the armature is overrun, causing the drive gear to disengage.

DIAGNOSING AND TESTING

PROBLEM	TEST SEQUENCE
1. Engine cranks but does not start.	Problem in ignition system (See page 40-15-4). Check seat switch and PTO safety switch, page 40-15-5.
2. Engine cranks a short time only.	A. Test battery. Page 40-10-5 B. Check connections. Page 40-10-7 and 40-10-10 C. Test starter.
3. Engine cranks slowly.	A. Test battery. Page 40-10-5 B. Check connections. Page 40-10-7 and 40-10-10 C. Test starter.
4. Engine does not crank	A. Test battery. Page 40-10-5 B. Check connections. Page 40-10-7 and 40-10-10 C. Test starter. Page 40-10-7 D. Test solenoid. Page 40-10-6 E. Test neutral-start safety switches. Page 40-10-6 F. Test ignition switch. Page 40-10-6

Cranking System Tests

A. Test Battery

1. Check battery specific gravity, page 40-10-5.
If battery is good, proceed to next test.
If discharged, charge battery.
If battery is in poor condition, replace battery.
2. Check battery voltage, page 40-10-5.
If good, proceed to next test.
If poor, replace battery.

B. Check Connections

1. Check all connections for looseness, corrosion, or breaks.

C. Test Starter

1. Connect battery directly to starter. If starter cranks engine, proceed to test solenoid, neutral-start safety switches and ignition switch. If starter does not crank engine, remove starter from tractor and test as instructed on page 40-10-7.
If starter engages but does not crank engine:
Check if PTO is engaged with load on PTO attachment.
Check for engine resistance such as seized piston, binding connecting rod, crankshaft bearings, or bushings. If engine and PTO turn freely, remove starter and check it for:
Dirty or gummed armature.
Shorted or grounded armature, page 40-10-7.
Misaligned start motor.

D. Test Solenoid

Connect battery directly to solenoid page 40-10-7. If solenoid energizes, test neutral-start safety switches. If solenoid fails to energize, replace solenoid.

E. Test Neutral-Start Safety Switches

Test Transmission Neutral-Start Safety Switch

Attach test light to the terminals, page 40-10-6. Place the shift lever in neutral position.

If test light lights, test neutral-start PTO safety switch.

If test light does not light, adjust switch as explained on page 40-10-6. If test light does not light after adjustment, replace switch.

Test PTO Neutral-Start Safety Switch

Attach test light to terminals on switch page 40-10-6. Place PTO lever in disengaged position.

If test light lights, test ignition switch.

If test light does not light, adjust switch as explained on page 40-10-6. If test light does not light after adjustment, replace switch.

F. Test Ignition Switch

Check for continuity between terminals with the switch placed in each of three positions as explained on page 40-10-6.

Testing Battery

Checking Battery Specific Gravity

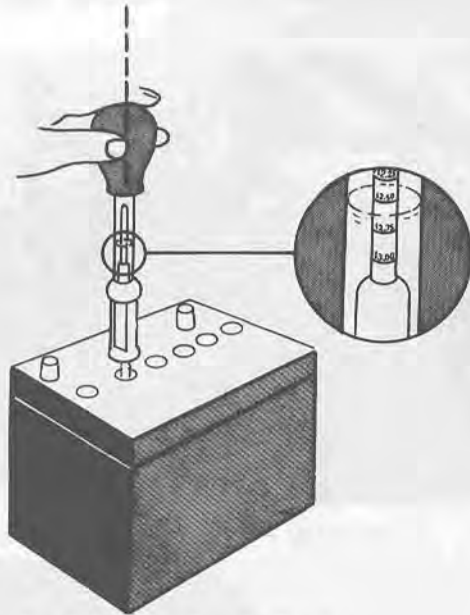

M16866N

Fig. 5-Checking Specific Gravity

To determine whether the battery is capable of meeting the requirements of the starting motor, it is necessary to duplicate operating conditions by subjecting the battery to a load test (checking battery voltage). To obtain a true test, the battery should be at least 75 percent charged. This can be determined by taking a hydrometer reading, Fig. 5.

The following table illustrates typical ranges of specific gravity (amount of unused sulfuric acid remaining in the solution) for a cell in various states of charge, with respect to its ability to crank the engine at 80°F (26.5°C) with initial full-charge specific gravity at 1.260 to 1.280.

Specific Gravity	Capacity
1.260 to 1.280	100%
1.230 to 1.250	75%
1.200 to 1.220	50%
1.170 to 1.190	25%
1.140 to 1.160	Very little useful capacity
1.110 to 1.130	Discharged

Checking Battery Voltage

With a battery in good condition, each cell contributes approximately 1.95 to 2.08 volts. If battery charge is low and less than 0.05 volt difference is noted between the highest and lowest cells, the battery may be recharged.

If this difference is more than 0.05 volts, this could indicate a cracked plate or other damage which could call for replacement of the battery.

There are two methods of testing battery capacity. Battery electrolyte temperature should be at or near 80°F (26.5°C) for these tests.

Before making either of the two following tests, first check electrolyte level in battery. Add water if necessary. If water is added, be sure it is thoroughly mixed with the underlying electrolyte by charging. Battery voltage should be 11.5 to 12.6 volts before testing. Refer to instructions supplied by test equipment manufacturer, when using high-rate discharge equipment.

The first method of testing should be to crank the engine for 15 seconds with the starting motor then measure the battery voltage. If voltage is less than 9.6 volts at the end of 15 seconds cranking, replace battery.

As a second method, use high-rate discharge test equipment. Discharge the battery by means of a heavy-duty carbon pile at a rate 3 times the ampere-hour capacity. Follow equipment manufacturer's recommendations for testing.

If after 15 seconds the battery voltage is less than 9.0 volts, the battery fails to meet the load test, indicating loss of capacity or internal short circuits. Any battery that passes the load test is a good battery and can be relied upon to fulfill the requirements of the starting motor under normal conditions.

Testing Ignition Switch

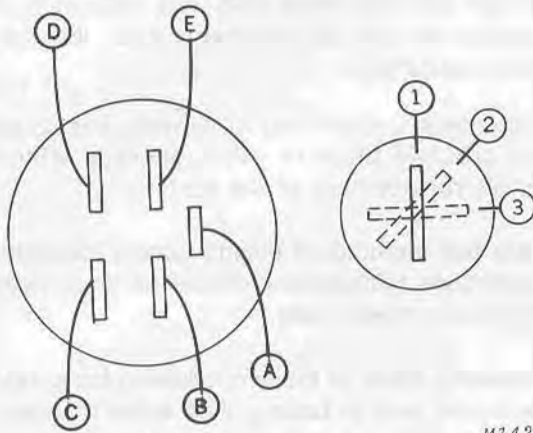

M14222N

Fig. 6-Test Ignition Switch

Remove battery to provide access. Remove coupler from ignition switch to expose terminals. The ignition switch can be tested with a test light. Check for continuity between terminals with switch placed in each of three positions. See Fig. 6, and chart below for current flow diagram. If switch is defective it must be replaced.

POSITION	CLOSED	OPEN
1 - OFF	-	A, B, C, D, E
2 - RUN	B, C, D, E	A
3 - START	A, B, D, E	C

Testing Neutral-Start Safety Switches

The cranking system has two neutral-start safety switches. Both of these switches must be closed to allow current flow to the starter solenoid. One switch is located on a mounting plate under the fender-deck and is activated by the shift lever follower. The other switch is mounted inside the pedestal under the dash and is operated by the PTO lever arm.

Neutral-start safety switch failure usually requires only adjustment to correct. If the solenoid will not activate when the PTO lever is in the disengaged position and the shift lever is in neutral, check for proper switch adjustment.

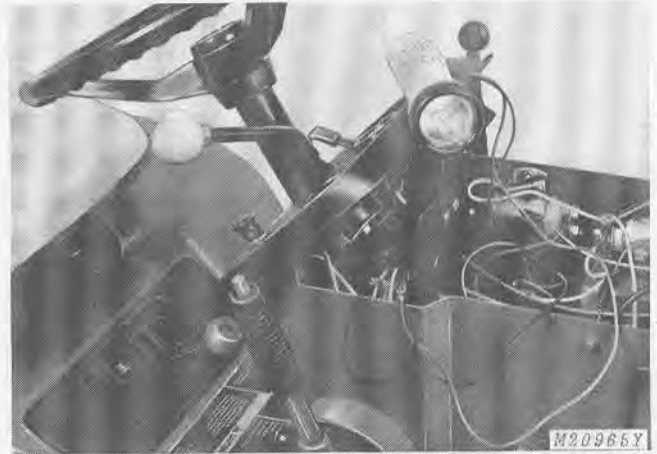

Fig. 7-Test PTO Neutral-Start Safety Switch

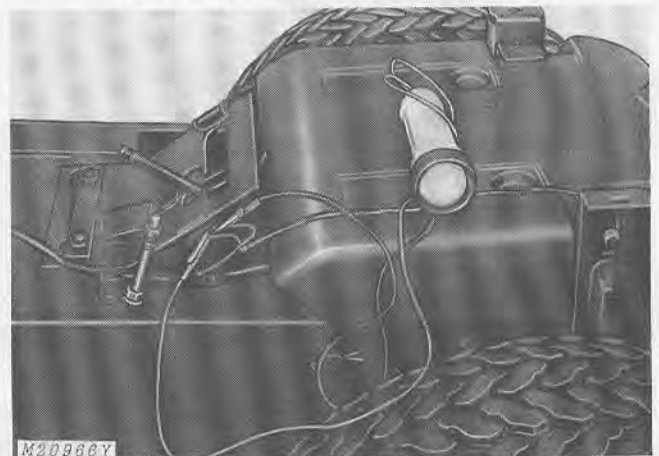
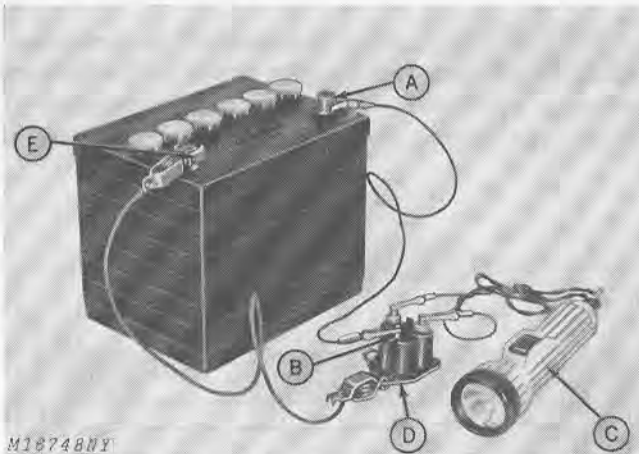

Fig. 8-Test Transmission Neutral-Start Safety Switch
(Fender-Deck Removed for Clarity)

To test the safety switches, connect a test light to the switch leads as shown in Figs. 7 and 8. If test light does not glow, check adjustments. To adjust the PTO neutral-start safety switch, Fig. 7, loosen the mounting screws and adjust until switch closes with the PTO in the disengaged position. If test light fails to light, replace switch. To adjust the transmission neutral-start safety switch, Fig. 8, loosen the mounting screws and adjust until the switch closes with the shift lever in neutral position. If test light fails to light, replace switch.

IMPORTANT: To prevent premature failure or damage to switch, be careful not to bottom plunger under switch roller when adjusting switch.

Testing Solenoid



M18748NY
A—Positive Battery Terminal
B—Ignition Switch Terminal
C—Test Light
D—Solenoid Base
E—Negative Battery Terminal

Fig. 9-Testing Solenoid

To test the solenoid, connect jumper wires from the negative battery post (E) to the solenoid base (D), and from the positive battery post (A) to the ignition switch terminal (B) at the solenoid. Connect a test light (C) between the two large terminals on the solenoid, Fig. 9. The light should light when the solenoid is activated.

NOTE: On tractors equipped with either hydraulic or electric lift, it may be necessary to remove the left-hand side panel, loosen left-hand pedestal side, and lay it back to gain access to the solenoid.

Testing Starter

If the starter fails to crank properly when the engine is known to be in good operating condition and the rest of the cranking circuit is found to be satisfactory, remove the starter and check it further. (See page 40-10-10 for removal and repair of starter.)

With the starter removed from the engine, check the armature for freedom of operation by turning the shaft. Tight, dirty or worn bushings, or a bent or worn armature shaft may cause the shaft to turn hard. Disassemble the starter for further testing.

Testing Armature

If inspection does not reveal the cause of failure, test the armature for opens, shorts, and grounds as follows:

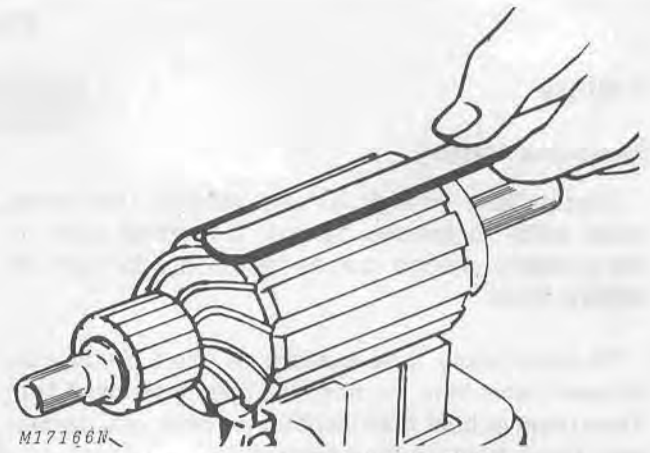

Fig. 10-Testing Armature for Shorts

1. SHORTS - A burned commutator bar indicates a shorted armature. Short circuits are located by rotating the armature on a growler with a steel strip (hacksaw blade) held on the armature, Fig. 10. The steel strip will vibrate on the area of the short circuit.

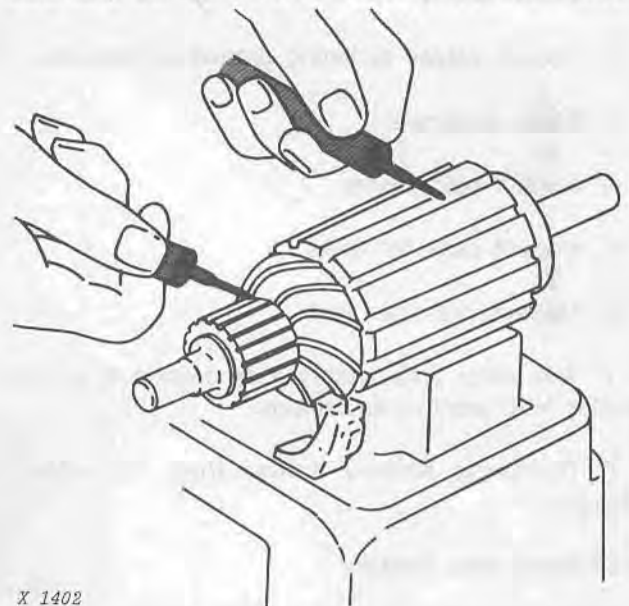

Fig. 11-Testing for Grounds

2. GROUNDS - Grounds in the armature can be detected with a test lamp and probes, Fig. 11. If the lamp lights when one test probe is placed on the commutator and the other probe on the armature core or shaft, the armature is grounded.

3. OPENS - Inspect for loose connections at the point where the armature windings are attached to the commutator bars. Poor connections cause arcing and burning of the commutator. Resolder any poor connections and turn armature commutator in a lathe to provide a good surface for brushes.

If tests reveal any of the above-listed conditions other than a repairable open circuit, replace the armature.

REPAIR

Battery

Removing Battery

Loosen bolts through terminal clamps. Use a terminal puller to remove clamps. If terminal puller is not available, spread clamps before prying them off battery posts.

To avoid injury from a spark or short circuit, disconnect cable from the negative battery terminal first. Then remove boot from positive terminal and disconnect cable from positive terminal.

Servicing Battery

Good battery servicing should include the following items:

1. Clean battery.
2. Inspect cables including ground connections.
3. Clean terminals.
4. Inspect hold-downs.
5. Inspect case for leaks.
6. Make hydrometer test.
7. Add water if necessary. Use caution to protect tractor from electrolyte damage.
8. Recharge battery if less than 75 percent charged.

Activating New Battery

When activating a new battery, remove battery from tractor before filling it with electrolyte. This will prevent damage to tractor in case electrolyte spills.

Add electrolyte until plates are just covered. Then charge at 30 to 40 amps for 10 minutes or 15 amps for 30 minutes.

Charging the battery will increase battery temperature and raise the electrolyte level. If electrolyte is still below the ring in the filler neck (A), add enough electrolyte to fill battery to the bottom of the ring. See Fig. 12.

CAUTION: After the battery is activated, hydrogen and oxygen gases in the battery are very explosive. Therefore, it is necessary to keep open flames and sparks away from battery.

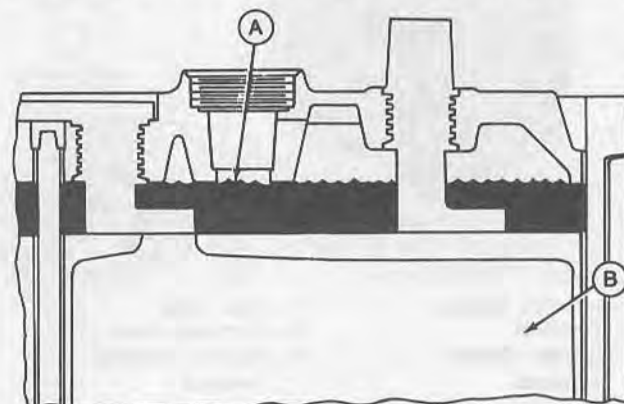

M16750N

A—Filler Neck

B—Battery Plates

Fig. 12—Proper Level of Electrolyte in Battery Cells

Checking Battery Electrolyte Level

Periodically check the level of the electrolyte in the battery cells. This should be done at least once a week during peak operating periods.

Proper level is normally to the bottom of the ring in the filler neck (A) so that the tops of the battery plates (B) are covered, Fig. 12. Do not overfill.

Add only distilled water to the battery. If not available, be sure to use clean, soft water. Avoid water with a high mineral content.

Never add acid to the battery unless electrolyte is lost by spilling. To add acid to the battery will unbalance the 10 to 1 sulfuric acid-to-water ratio.

Always wait until after checking specific gravity before adding water to the battery. This will assure a true reading. If level is too low to check specific gravity, add water and operate system for a few minutes to mix water and electrolyte, then check.

In freezing weather, never add water to the battery unless tractor will be operated for a period of time to allow mixing of the water and electrolyte.

Installing Battery

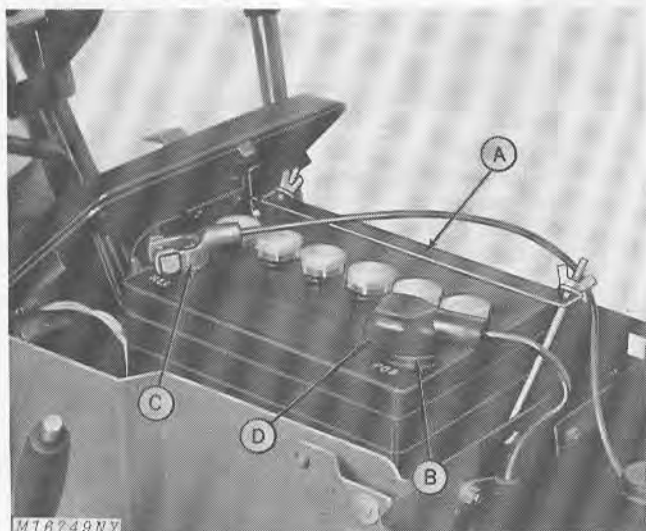

A—Battery Hold-Down
B—Positive Battery Terminal
C—Negative Battery Terminal
D—Rubber Boot

Fig. 13—Installing Battery

Clean and dry battery exterior. Position battery and install battery hold-down (A), Fig. 13.

Never hammer terminal clamps onto battery posts when connecting battery cables. To do so could result in damage to the battery.

Attach positive cable to positive (+) battery terminal (B).

Attach ground cable to negative (-) battery terminal (C). Coat both terminals with petroleum jelly.

IMPORTANT: Slide rubber boot (D) over positive battery terminal (B) until terminal and clamp are completely covered.

Be sure top and bottom vent holes in each cell cap are open.

NOTE: Damage to the alternator-stator or rectifier-regulator can occur if battery polarity is reversed, if the battery is fast charged, or if welding is done on the tractor. Always connect positive cable to positive post, negative cable to negative post. Disconnect the connector from the regulator before charging, jumping or welding.

Cleaning Battery

Corrosion around the battery terminals is normal. However, an accumulation of corrosion over a long period can shorten the life of the battery. It is therefore important to keep battery terminals as clean as possible.

To clean terminals, remove battery from tractor. Remove all corrosion using a wire brush. Wash terminals using a solution of one part ordinary baking soda to four parts water. Do not permit cleaning solution to enter battery cells.

Wash entire battery case, battery base and hold-down strap with clear water.

REPAIR—Continued

Starter

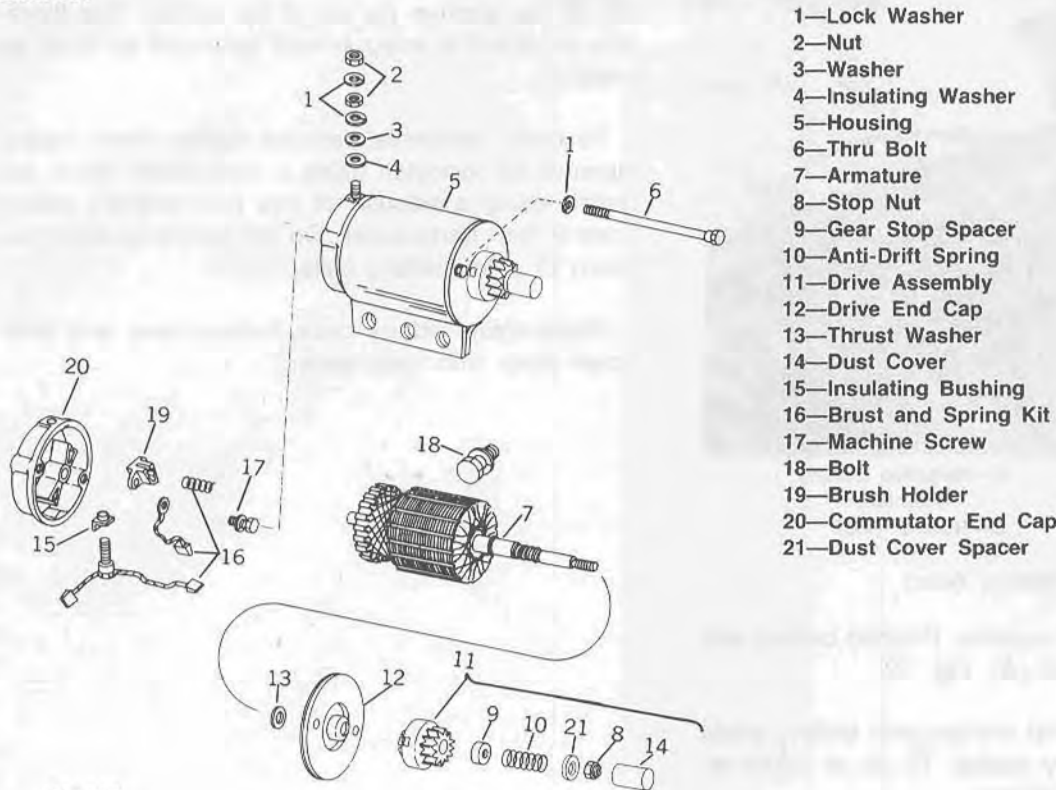

- 1—Lock Washer
- 2—Nut
- 3—Washer
- 4—Insulating Washer
- 5—Housing
- 6—Thru Bolt
- 7—Armature
- 8—Stop Nut
- 9—Gear Stop Spacer
- 10—Anti-Drift Spring
- 11—Drive Assembly
- 12—Drive End Cap
- 13—Thrust Washer
- 14—Dust Cover
- 15—Insulating Bushing
- 16—Brush and Spring Kit
- 17—Machine Screw
- 18—Bolt
- 19—Brush Holder
- 20—Commutator End Cap
- 21—Dust Cover Spacer

M11627

Fig. 14—Exploded View of Starter

Removing Starter

NOTE: Engage PTO lever for access to cap screws that secure starter to engine block.

Remove left-hand side panel and left-hand pedestal side to provide access to starter.

Remove starter cable and two cap screws securing starter to engine block.

Disassembling Starter

Remove dust cover (F) from end of starter drive, Fig. 15. Hold drive gear (A) and remove 3/8-inch stop nut (E). Remove drive parts from armature shaft.

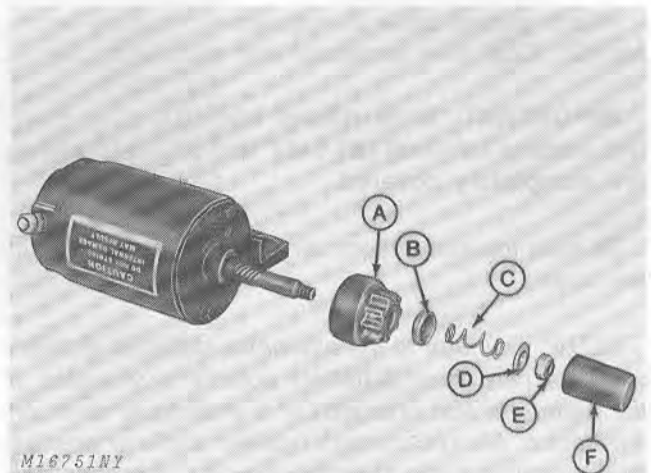

- A—Drive Gear
- B—Gear Stop Spacer
- C—Anti-Drift Spring
- D—Dust Cover Spacer
- E—Stop Nut
- F—Dust Cover

Fig. 15—Disassembling Starter Drive

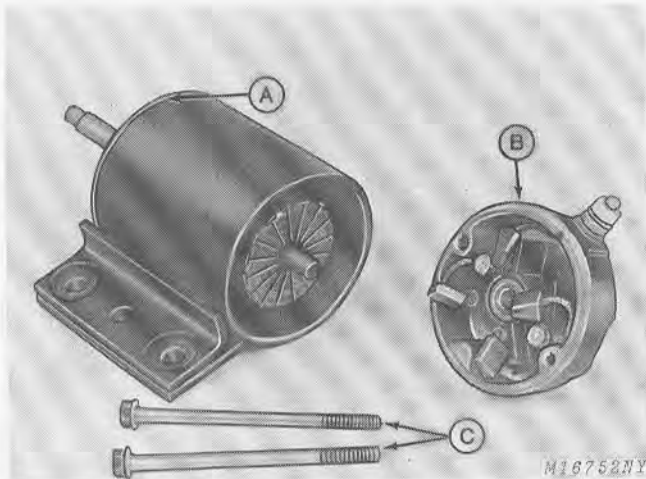

A—Drive End Cap C—Thru Bolts
B—Commutator End Cap

Fig. 16-Disassembling Starter

Remove the two thru bolts (C) which hold the end caps (A and B) to starter housing, Fig. 16.

Remove commutator end cap (B) carefully, Fig. 16, to avoid losing brush springs which may pop out when end cap is removed.

Inspection

Clean and inspect starter drive components for excessive wear. Replace parts as necessary.

See "Testing Starter" on page 40-10-7.

Inspect bearing in mounting bracket and end cap. Also inspect armature shaft. If armature shaft has excessive play in bearings, replace end caps. It may be necessary to replace armature if bearing surfaces are worn badly. Excessive bearing play will allow armature to rub against fields.

Clean and inspect commutator. If surfaces are badly grooved, true up on a lathe and undercut mica. Brushes must make good contact with commutator.

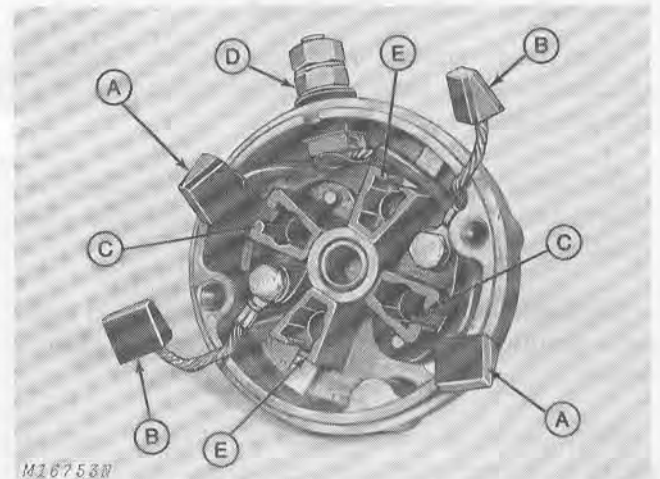

A—Input Brushes D—Input Terminal
B—Ground Brushes E—Non-Insulated Brush
C—Insulated Brush Holders Holders

Fig. 17-Replacing Brushes

Replace brushes whenever they show any amount of wear. To replace input brush assembly (A), remove nuts and washers from input terminal (D) and pull the brushes out through the inside of cap. When assembling, place the input brushes (A) into the insulated brush holders (C), Fig. 17.

The leads from the ground brushes (B) are attached to the metal screws which secure the insulated brush holders (C) to the end cap, Fig. 17. Place the ground brushes (B) in the non-insulated brush holders (E).

Assembling Starter

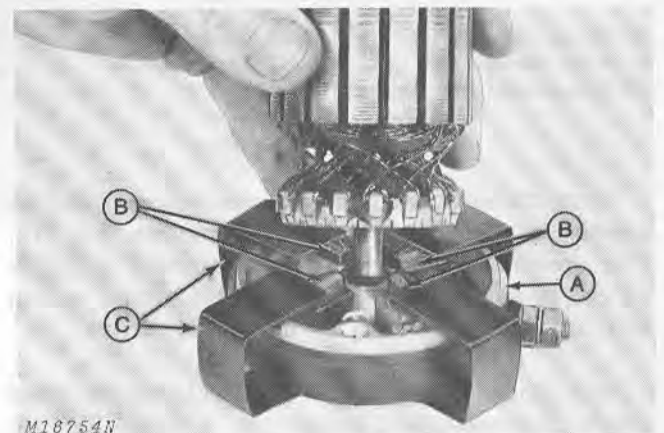

A—End Cap B—Brushes C—Retaining Clips

Fig. 18-Installing Brushes

Preparing the starter end cap (A), Fig. 18, is the first step of starter assembly.

Assembling Starter—Continued

Place brush springs into brush holders. Then, in succession, place each brush in its respective holder with the beveled side up.

Compress brush spring and place a U-shaped retaining clip (C) made of banding steel onto each brush, Fig. 18.

Wipe commutator clean with a dry cloth and lubricate armature shaft with a small amount of light grease.

Place armature into end cap (A), Fig. 18, and remove U-shaped brush retaining clips.

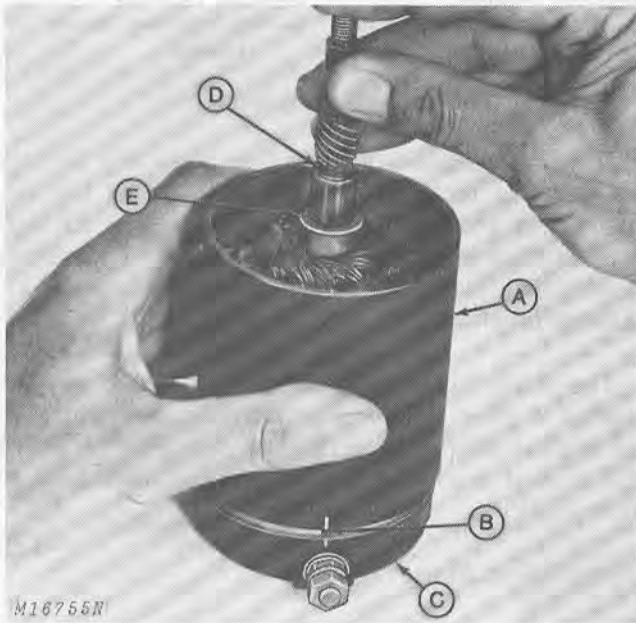

A—Starter Housing
B—Index Marks
C—Commutator End Cap
D—Armature
E—Thrust Washer

Fig. 19—Aligning Index Marks

Place starter housing (A) over armature (D) while exerting down pressure on the armature, Fig. 19. This prevents brush springs from pushing armature up and away from end cap (C). If this occurs, reload brushes into end cap and reassemble.

Align housing (A) with end cap (C) using the index marks (B) on cap and housing as a guide, Fig. 19.

Place thrust washer (E) onto armature shaft, Fig. 19. Lubricate drive end cap bearing with light grease.

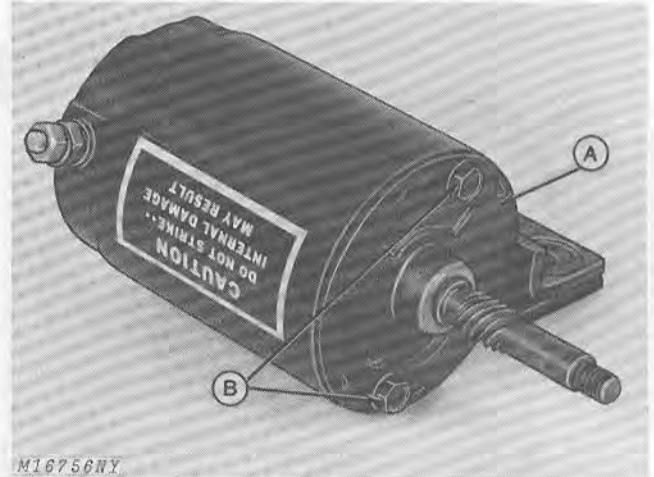

A—Drive End Cap
B—Thru Bolts

Fig. 20—Assembling Drive End Cap

Install drive end cap (A), Fig. 20 onto armature.

NOTE: The starter housing has a mark and an indentation on the inside which must fit into the two indentures on the drive end cap.

Insert thru bolts (B), Fig. 20, and tighten to 20 to 25 in-lbs (0.2597 to 0.3246 Nm) torque.

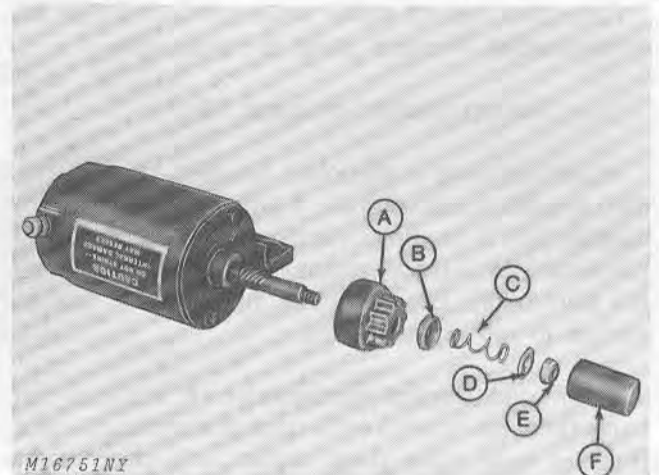

A—Drive Gear
B—Gear Stop Spacer
C—Anti-Drift Spring
D—Dust Cover Spacer
E—Stop Nut
F—Dust Cover

Fig. 21—Assembling Starter Drive

Lubricate armature shaft splines with a light coat of oil. Install drive assembly components as shown, Fig. 21. Tighten stop nut (E) to 45 to 50 in-lbs (0.5843 to 0.6492 Nm) torque.

Install starter on engine.

Group 15 IGNITION SYSTEM

PRINCIPLE OF OPERATION

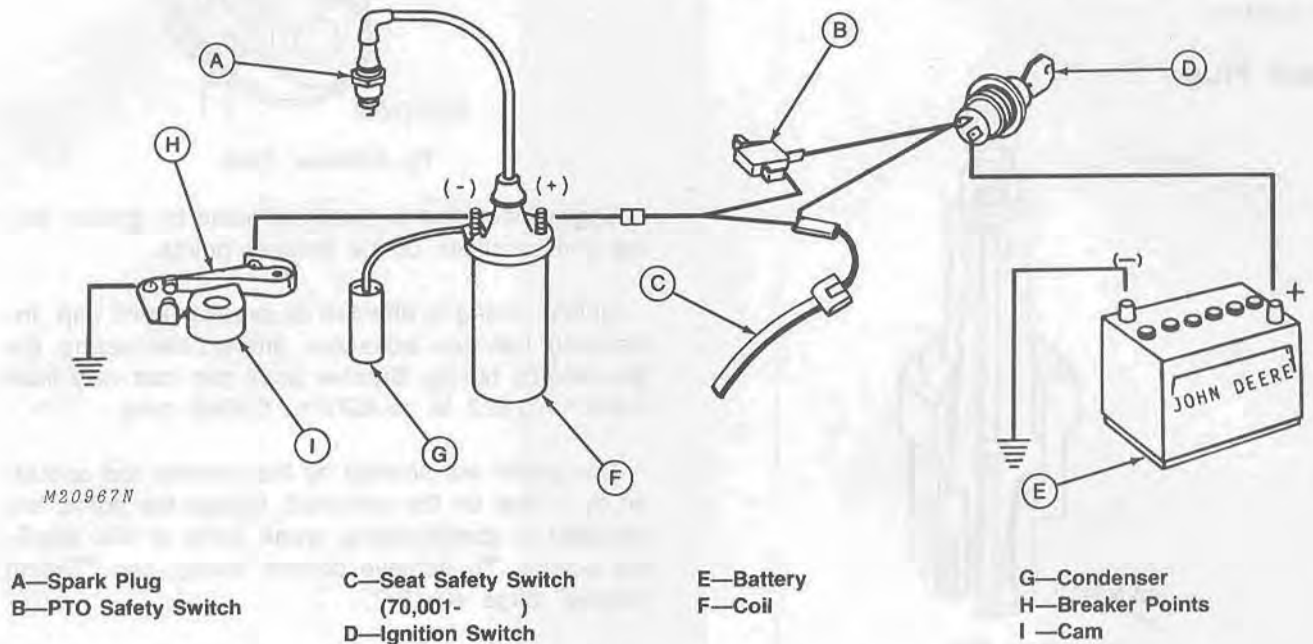

Figure 1—Ignition System Components

All 200 Series Tractors have a battery coil ignition system.

When the ignition switch is closed, current will flow from the battery (E) to the coil (F) only if (either or both) the PTO safety switch (B) is closed (closed with PTO disengaged) or the seat switch (C) (70,001-) is closed (closed when seated on tractor). Current flows through the primary windings of the coil (F) through the breaker points (H) when closed, then to ground.

At the point when the piston is near top-dead-center on the compression stroke, the breaker points (H) are opened by the cam (I).

When the points are opened, the primary circuit is broken and the magnetic field within the coil collapses.

With the collapse of the primary field, the magnetic lines of force cut across the secondary coil windings and a high-voltage is induced. The high-voltage developed in the secondary windings cause the current to jump across the spark plug (A) electrode gap, producing a spark.

The residual current in the primary winding is absorbed by the condenser (G). This eliminates arcing at the points and aids in producing a stronger spark at the spark plug.

Ignition Switch

The ignition switch in the battery coil ignition system routes the electrical current from the battery to the coil in both "START" and "RUN" positions. Since electrical current is needed to operate the ignition coil, a switch with a closed ignition circuit is required. This means that opening the circuit will stop the ignition function.

Spark Plug

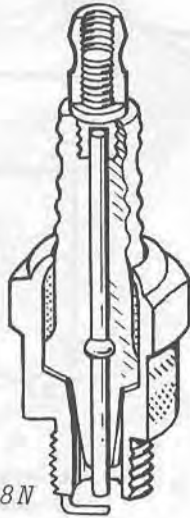

M5598N

Fig. 2-Spark Plug

A spark plug, Fig. 2, consists mainly of two electrodes separated from each other by a specific gap. The side electrode is connected to the shell of the spark plug. The center electrode is completely insulated from the shell. The high-voltage produced in the secondary winding of the coil is applied to the center electrode and causes a spark to jump the gap to the side electrode. The spark, inside the cylinder, ignites the fuel-air mixture and starts the combustion process in the combustion chamber of the cylinder.

The gap spacing between electrodes is critical for efficient engine operation. Correct spark plug gap affects the entire range of performance of the engine; starting, idling, accelerating, power, and top speed.

Breaker Points

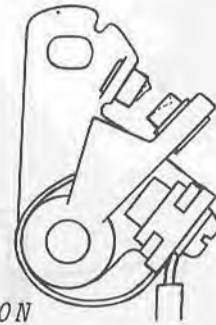

M5600N

Fig. 3-Breaker Points

Engine operation is greatly affected by ignition timing and condition of the breaker points.

Ignition timing is affected by breaker point gap. Increasing the gap advances timing; decreasing the gap retards timing. Breaker point gap can vary from 0.018 to 0.022 in. (0.4572 to 0.5588 mm).

The points are opened by the breaker rod operated by a lobe on the camshaft. Unless the points are adjusted to specifications, weak, early or late sparking occurs. To achieve correct timing, see "Timing Engine" page 40-15-7.

Replace badly burned or pitted breaker points. If points are oxidized, rub a piece of coarse cloth across surfaces. Clean dirty or oily points with cloth, but make sure no particles of lint are left between surfaces.

Condenser

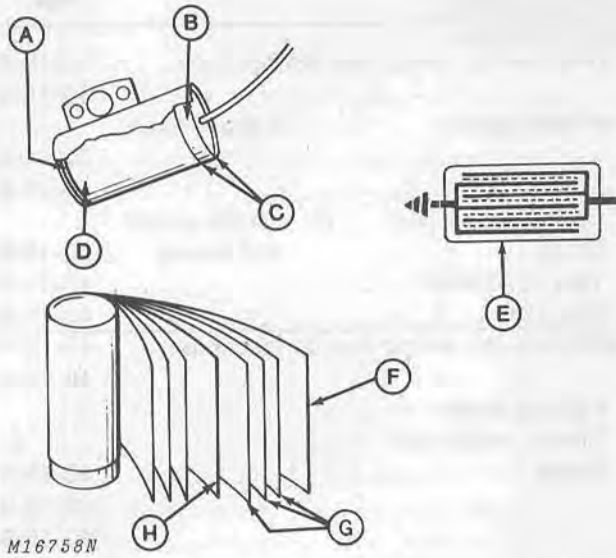

- | | |
|-----------------------|------------------------|
| A—Spring | E—Construction Section |
| B—Gasket | F—Foil |
| C—Hermetically Sealed | G—Insulation |
| D—Pressure Contact | H—Foil |

Fig. 4-Cutaway View of Condenser

When the magnetic field in the coil collapses, voltage much higher than the original voltage is induced into the primary winding. As the breaker points open, the current tends to continue flowing across the points. The resulting arc would damage the points in a short time. The condenser, by absorbing the surge of high-voltage, dampens the tendency of current to arc across the points. The condenser also allows the magnetic field to collapse rapidly which contributes to high-voltage induced into the secondary windings.

Coil

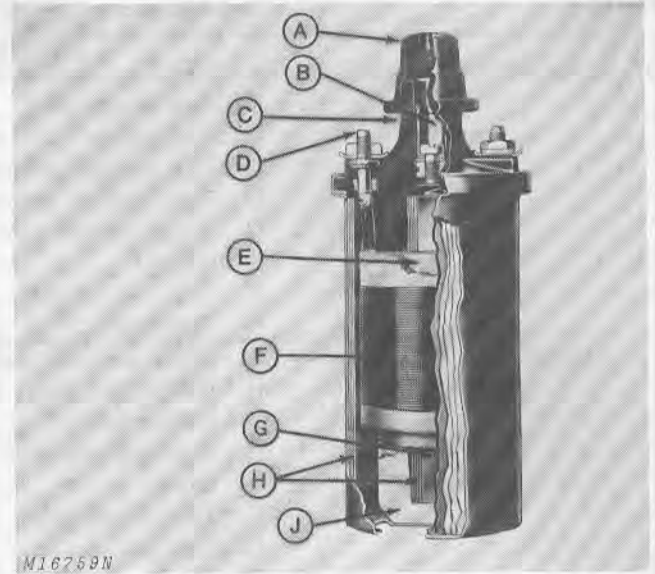

- | | |
|-------------------------|-----------------------|
| A—Sealing Nipple | E—Secondary Winding |
| B—High-Tension Terminal | F—Primary Winding |
| C—Coil Cap | G—Iron Core |
| D—Primary Terminal | H—Lamination |
| | J—Porcelain Insulator |

Fig. 5-Cutaway View of Coil

The ignition coil is a pulse transformer that steps up low voltage from the battery to the high-voltage necessary to ignite the fuel-air mixture at the spark plug gap.

The coil contains three basic parts: A primary winding consisting of a few hundred turns of relatively heavy wire, a secondary winding consisting of many thousand turns of very fine wire, and laminated soft iron which serves to concentrate the magnetic field. These three units are placed in the coil case and immersed in oil. The coil cap with its necessary attachments to the windings completes the entire coil.

When the primary circuit is energized (breaker points closed), a magnetic field is built up around both the primary and secondary coils. When the primary circuit is de-energized (breaker points open), the magnetic field collapses about the coils inducing a voltage within both of the coils. The voltage developed within the primary coil is absorbed and dissipated by the condenser. The voltage developed within the secondary coil (possible 25,000 volts or more) is distributed to the spark plug for igniting the fuel-air mixture within the cylinder.

DIAGNOSING AND TESTING

Problem	Test Sequence	Page	
1. Engine Will Not Start	A. Make a visual check of components, wiring and connections	40-15-4	
	B. Test spark plug	40-15-5	
	If No Spark:	If Weak Spark:	If Strong Spark:
	C. Test safety switches		40-15-5
	D. Test ignition switch		40-15-6
	E. Check points and timing	E. Check points and timing	E. Check points and timing 40-15-6
	F. Test condenser	F. Test condenser	40-15-9
2. Engine Hard Starting	G. Test coil	40-15-9	
	A. Make a visual check of components, wiring and connections	40-15-4	
	B. Test spark plug	40-15-5	
	If Weak Spark:	If Strong Spark:	
	E. Check points and timing	E. Check points and timing	40-15-6
	F. Test condenser		40-15-9
	G. Test coil		40-15-9
3. Engine Misfires or Lack of Power	A. Make a visual check of components, wiring and connections	40-15-4	
	B. Test spark plug	40-15-5	
	E. Check points and timing	40-15-6	
	F. Test condenser	40-15-9	
	G. Test coil	40-15-9	
4. Engine Overheats or Engine Knocks	A. Make a visual check of components, wiring and connections	40-15-4	
	B. Test spark plug	40-15-5	
	E. Check points and timing	40-15-6	
5. Engine Starts But Will Not Continue to Run	A. Make a visual check of components, wiring and connections	40-15-4	
	B. Test spark plug	40-15-5	
	If Weak Spark:	If Strong Spark:	
	E. Check points and timing	C. Test safety switches	40-15-5
	F. Test condenser	D. Test ignition switch	40-15-6
	G. Test coil	E. Check points and timing	40-15-6
			40-15-9

A. Make a Visual Check of Components and Wiring

Make a visual check of the ignition circuit to find broken leads, broken or loose connections, corroded connections, possible cracks or broken components.

B. Test Spark Plug

Remove ignition cable from spark plug and install adaptor, Fig. 6, or an ordinary paper clip. Hold adaptor approximately 1/8 inch (3.18 mm) away from spark plug terminal while cranking engine.

If there is no spark at the plug terminal, hold the high-tension lead at the steel base of the plug while cranking engine. If a spark jumps here, the plug is bad and should be cleaned or replaced.

B. Test Spark Plug—Continued

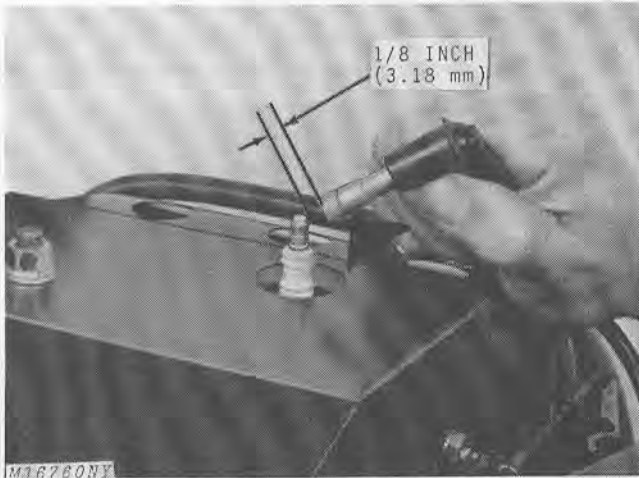

Fig. 6—Checking Spark at Plug

A weak spark or no spark indicates ignition system difficulties. Test further to isolate problem.

A sharp, snapping spark indicates coil, breaker points, and condenser are in good condition.

Every 100 hours, remove, inspect, and regap spark plugs to 0.025-inch (0.6350 mm) on 200 Tractors and 0.035-inch (0.8890 mm) on 210, 212 and 214 Tractors. Bend only the outer electrode when setting gap.

Do not sandblast, wire brush, scrape, or otherwise service a plug in poor condition. Install a new plug.

Use a spark plug wrench to remove and replace plug. Tighten plug to 27 ft-lbs (26.6 Nm) torque.

Good operating conditions are indicated if plug has a light coating of gray or tan deposit. A dead white, blistered coating could indicate overheating.

A black (carbon) coating may indicate an over-rich fuel mixture caused by a clogged air cleaner or improper carburetor adjustment.

C. Test Safety Switches

Test safety switches with a test light and check for continuity between terminals.

IMPORTANT: Be sure test light leads do not touch each other to ensure proper testing.

PTO Safety Switch

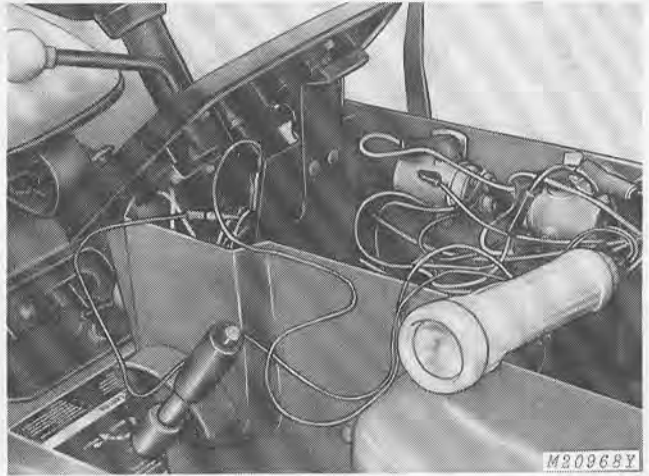

Fig. 7—Testing PTO Safety Switches

Attach test light leads to terminals of top PTO safety switch. Engage and disengage PTO. Light should glow with PTO disengaged. Light should go out when PTO is engaged. If the test light does not glow with PTO disengaged, check switch adjustment. To adjust, loosen mounting screws and adjust until switch closes with the PTO disengaged. If switch is adjusted correctly and test light fails to light, replace the switch.

Seat Safety Switch

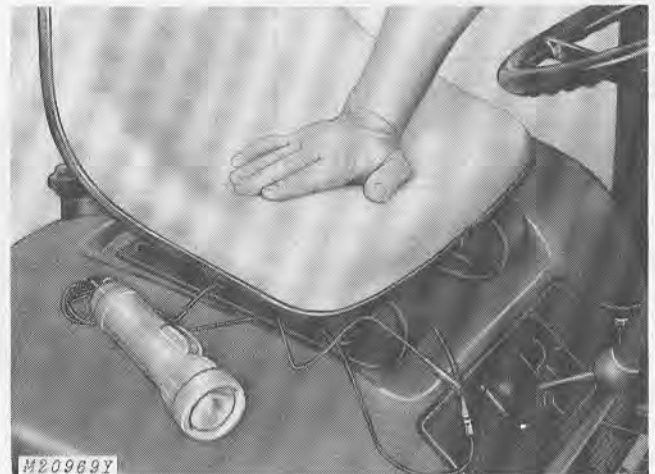
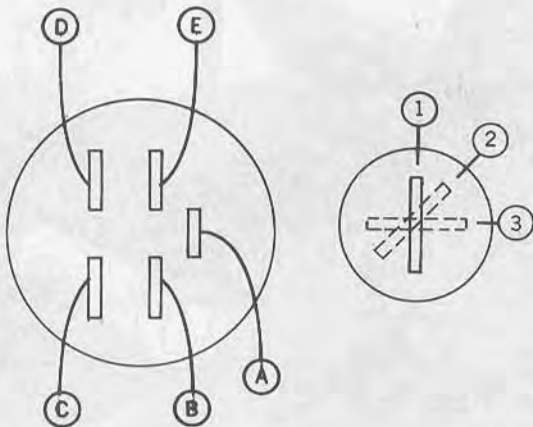

Fig. 8—Testing Seat Safety Switch

To test seat switch, disconnect coupler at seat switch. Attach leads of test light to coupler terminals at the switch. The test light should glow when pressure is applied to seat cushion and go out when cushion is released. If switch does not operate correctly, replace switch.

D. Test Ignition Switch



M14222N

Fig. 9-Testing Ignition Switch

Remove battery to provide access. Remove coupler from ignition switch to expose terminals.

The ignition switch can be tested with a test light. Check for continuity between terminals with switch placed in each of three positions. See Fig. 9 and chart below for correct current flow diagram. If switch is defective, it must be replaced.

POSITION	CLOSED	OPEN
1 - OFF	-	A, B, C, D, E
2 - RUN	B, C, D, E	A
3 - START	A, B, D, E	C

NOTE: Prior to removing any switch, be sure current is reaching the switch.

E. Adjust Breaker Points

CAUTION: Disconnect spark plug cable to prevent engine starting accidentally.

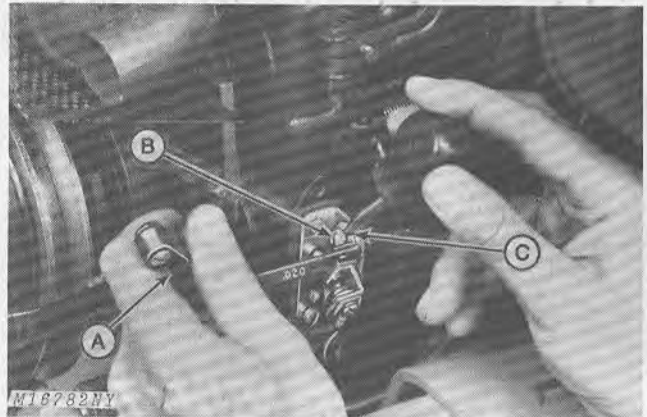

A—Feeler Gauge B—Locking Screw C—V-Slot

Fig. 10-Adjusting Breaker Points

Remove ignition point cover and rotate engine fly-wheel until points are at their widest opening.

Check point gap with a 0.020 inch feeler gauge (A). If adjustment is required, loosen locking screw (B) and move screwdriver in V-slot (C) until points are properly set. After tightening locking screw (B), recheck point gap.

Engine operation is greatly affected by breaker point condition and adjustment. If points are burned or badly oxidized, little or no current will pass. As a result, the engine may not operate at all or may miss particularly at full throttle.

Replace Breaker Points

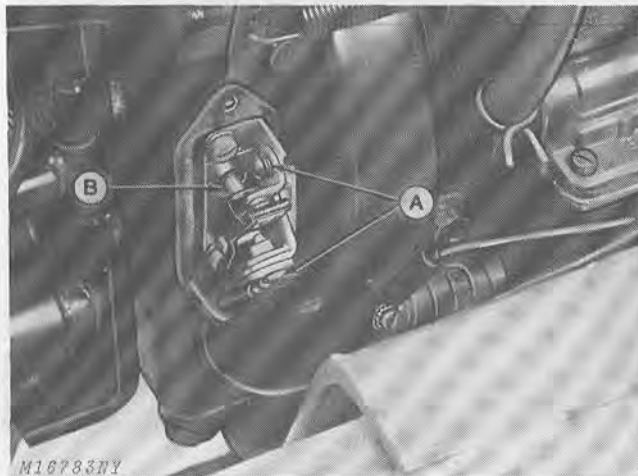

A—Breaker Point
Attaching Screws B—Push Rod

Fig. 11—Replacing Breaker Points and Condenser

To replace points, remove point cover; then remove attaching screws (A), Fig. 11.

Check condition of breaker point push rod (B). An excessively tight push rod can hang-up and cause ignition failure, particularly with a hot engine.

Install new points. Replace cover, being certain rubber grommet and cover gasket are in position and in good condition.

Time Engine

The engine is equipped with a timing sight hole in the blower housing.

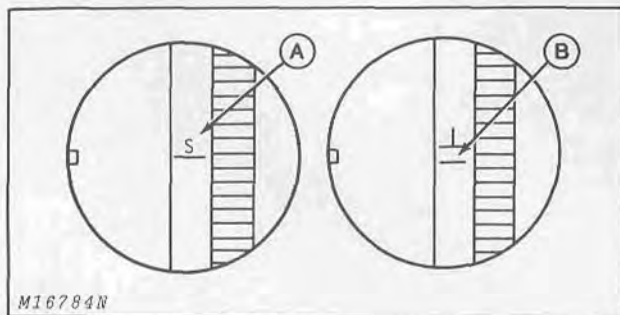

A—Spark Point B—Top Dead Center

Fig. 12—Timing Marks and Indicator

Two timing marks are stamped on the flywheel, Fig. 12. The "T" mark (B) indicates top dead center (TDC), while the "S" mark (A) indicates the spark point, which is 20 degrees before TDC.

Two methods are used for timing - the static and timing light methods.

Litho in U.S.A.

Static Timing Method

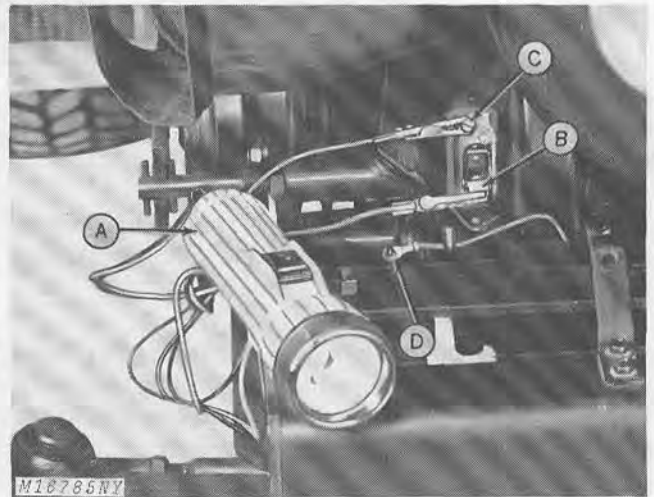

A—Flashlight Tester C—Ground
B—Lead Screw D—Lead

Fig. 13—Static Timing

Connect an ohmmeter or flashlight tester (A) to breaker point lead screw (B) and to ground (C), Fig. 13. Breaker point lead (D) must be disconnected from points.

Rotate engine normally until test light goes out, indicating points are just starting to open. At this time, the "S" mark on flywheel should be in alignment with the mark on the flywheel housing as shown in Fig. 12. If necessary, adjust gap slightly to obtain this condition.

Time Engine—Continued

Timing Light Method

Several different types of timing lights are available. Follow manufacturer's instructions for type used. The following timing procedure can be used with most timing lights.

Remove high-tension lead at spark plug. Install adapter, Fig. 6, page 40-15-5, and reconnect spark plug lead.

Connect one timing light lead to this adapter. Connect second timing light lead to positive side of battery. See timing light instructions for battery size, wiring, etc. Connect third timing light lead to ground.

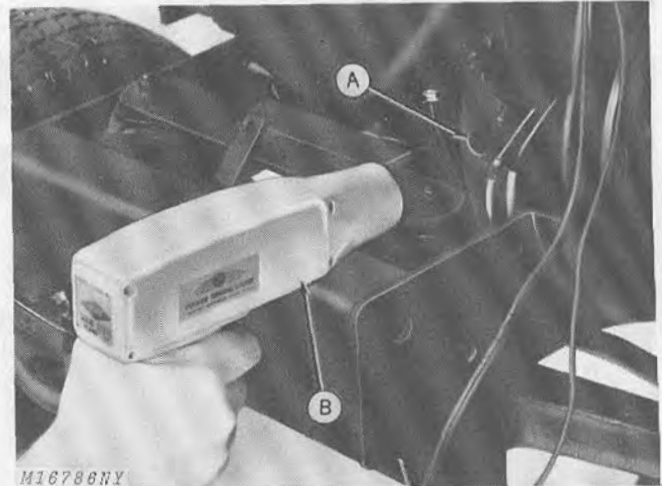

A—Sight Hole

B—Timing Light

Fig. 14—Timing With Light

Rotate engine by hand until "S" mark is visible through sight hole (A), Fig. 14. Chalk "S" line for easy reading.

Run engine at 1200 to 1800 rpm. Aim timing light (B), Fig. 14, into sight hole (A). The light should flash just as "S" mark is in alignment with mark on flywheel housing inside sight hole as shown, Fig. 12, page 40-15-7.

If timing is off, adjust breaker point gap slightly to correct.



F. Test Condenser

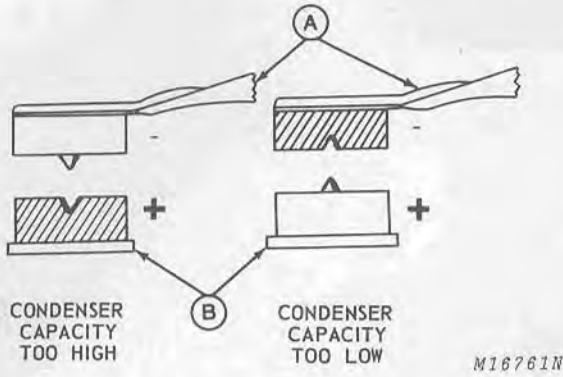

A—Movable Contact B—Stationary Contact

Fig. 15—Breaker Point Build-Up

If badly burned breaker points occur frequently, the condenser should be suspected. If condenser capacity is too small, metal will transfer from the stationary contact (B) to the movable contact (A) as illustrated in the left-hand half of Fig. 15. If capacity is too large, the metal will build up on stationary contact (B), right-hand half of Fig. 15.

Condensers can be tested off the tractor on test units such as the one shown in Fig. 16. Follow manufacturer's recommendations to make the following condenser tests:

1. Capacity
2. Leakage
3. Short
4. Series resistance



Fig. 16—Testing Condenser Capacity

If inspection or tests disclose a defective condenser, replace condenser. Install a new condenser whenever condition of points indicate need.

G. Test Coil

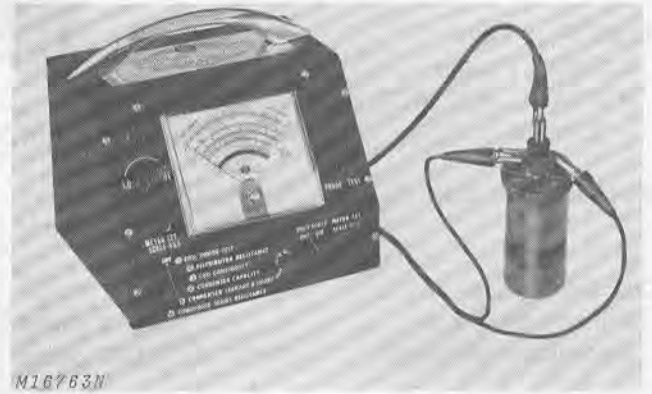

Fig. 17—Testing Coil Power

The ignition coil is either satisfactory or not. Coil failure occurs all at once, much as an electric light bulb. It does not degenerate gradually.

When coil failure is suspected, use an analyzer, Fig. 17 to test coil.

Follow manufacturer's recommendations to test the following:

1. Coil power test
2. Coil high-speed test
3. Coil surface insulation test
4. Coil continuity test
5. Coil ground test

Testing Coil for Grounded Windings

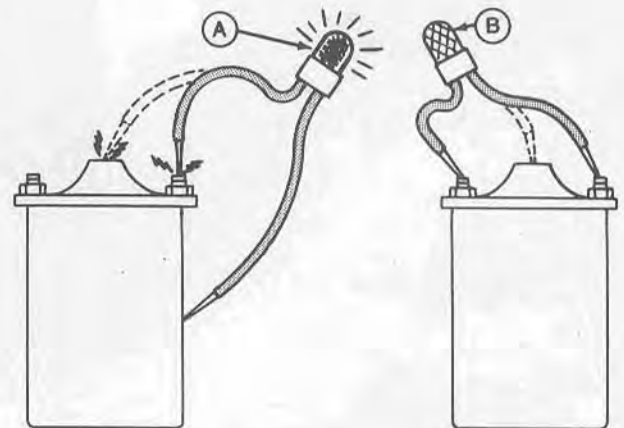

M16764N

A—Lamp Lights = Grounded Winding
B—Lamp Does Not Light = Open Winding

Fig. 18—Testing Coil for Grounded or Open Windings

To test the windings, use a test lamp and probes, Fig. 18.

SPECIFICATIONS

Spark Plug Gap

K181QS Engine 0.025 in. (0.6350 mm)

K241AQS, K301AQS and K321AQS

Engines 0.035 in. (0.8890 mm)

Breaker Point Gap 0.018 to 0.022 in.
(0.4572 to 0.5588 mm)

Coil Resistance

Primary Windings 2 to 3 ohms

Secondary Windings 8,000 to 10,000 ohms

Condenser

Capacity-Microfarads 0.18 to 0.23 mfd



Group 20 CHARGING SYSTEM

PRINCIPLE OF OPERATION

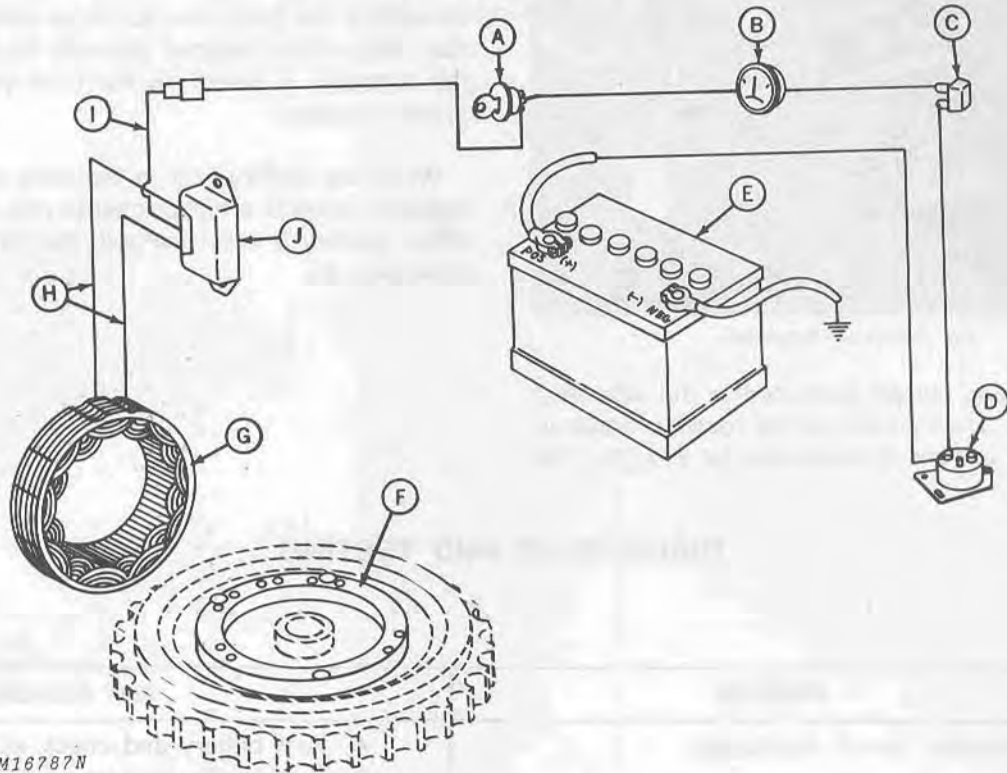

A—Key Switch
B—Ammeter
C—Circuit Breaker

D—Solenoid
E—Battery
F—Magnetic Flywheel Ring

G—Alternator-Stator
H—AC Leads
I—B+ Lead
J—Rectifier-Regulator

Fig. 1-Charging System Components

Alternator

A 15-amp alternator supplies electrical energy to charge the 12-volt battery. The battery, in turn, furnishes energy for cranking, ignition and accessories.

The alternator features (1) a magnetic ring (F), permanently affixed to the inside rim of the flywheel, an alternator-stator assembly (G) bolted to the engine bearing plate, and a rectifier-regulator (J) connected to it and mounted to the engine.

The magnetic ring (F) on the flywheel is made of a brittle ceramic material. Care should be used when handling the flywheel to prevent damage to the magnets.

The magnetic ring rotates around the stator, generating an alternating current in the stator

windings. This alternating current is routed to the rectifier-regulator where it is converted to direct current (DC). Direct current conversion is required because the polarity of the battery will not accept alternating current.

The rectifier-regulator also controls the rate of charge to the battery, depending on battery requirements.

With this system, the battery and alternator work hand-in-hand to supply the needs of the engine and accessories—each one being dependent upon the other.

Rectifier-Regulator



Fig. 2-Rectifier-Regulator

The alternating current produced in the alternator is changed to direct current in the rectifier-regulator, Fig. 2. Direct current is necessary for charging the battery.

This change is accomplished through the use of solid state electronic devices which are arranged to form a half-wave bridge rectifier.

Regulation is also provided by electronic devices (Zener Diodes) which "sense" the counter-voltage created by the battery to control or limit the charging rate. Since these devices generate heat in operation, the regulator is finned on the back side to provide greater cooling.

When the battery is in a low state of charge, the regulator permits a higher charge rate to the battery. When battery is fully charged, the devices limit the charging rate.

DIAGNOSING AND TESTING

PROBLEM	TEST SEQUENCE
1. Battery remains low or discharged.	A. Test battery and check all connections. B. Test rectifier-regulator. C. Test alternator stator. D. Check circuit breaker.
2. Battery uses too much water or battery is spewing electrolyte.	A. Test battery and check all connections. B. Test rectifier-regulator.
3. No DC output from rectifier-regulator.	A. Check all connections. B. Test rectifier-regulator. C. Test alternator stator. D. Check circuit breaker.
4. Unsteady or low alternator output.	A. Check all connections. C. Test alternator stator.
5. No AC output from alternator.	A. Check all connections. C. Test alternator stator.

Charging System Tests

A. Test battery and check all connections

See page 40-10-5 for battery tests.



Fig. 3-Poor Connections

A visual inspection will often reveal much useful information about the charging system. Poor connections between the regulator and battery, or poor ground connections between the battery to engine and engine-to-frame, will cause unwanted resistance.

Unwanted resistance in the circuit results in unwanted voltage losses. An excessive voltage loss in the charging circuit tends to keep the battery in an undercharged condition.

B. Test Rectifier-Regulator

To test the rectifier-regulator (G) Fig. 4, connect the voltmeter leads (B) from a DC volt-ammeter (F) across the battery terminals. At the same time connect an ammeter lead (E) between the B+ lead (D) from the rectifier-regulator (G) and the positive battery terminal (A), Fig. 4.

NOTE: The battery must be in a partially discharged condition.

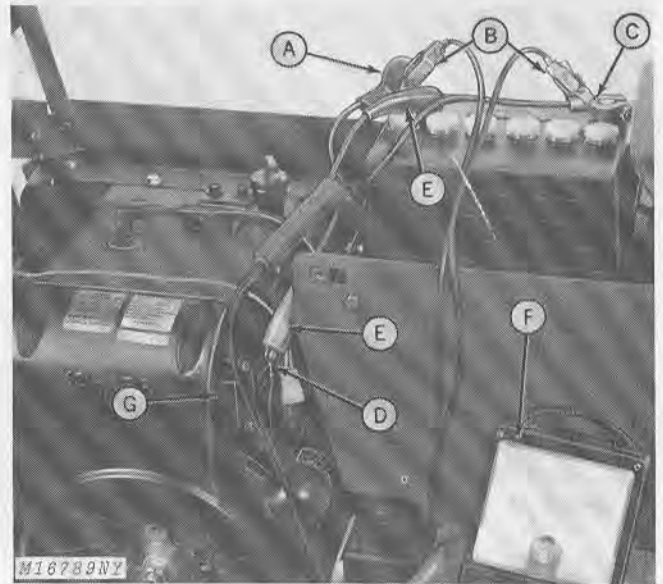

- | | |
|-----------------------------|-----------------------------|
| A—Positive Battery Terminal | D—B+ Lead |
| B—Voltmeter Leads | E—Ammeter Lead |
| C—Negative Battery Terminal | F—Volt-Ammeter (Dual Meter) |
| | G—Rectifier-Regulator |

Fig. 4-Testing Rectifier-Regulator

Run the engine at full throttle (3500 rpm).

The volt-ammeter (F) should show approximately a 15 amp output until the battery reaches a charge of 13.8 to 14.7 volts. At this time amp output should begin to drop off.

If amp output does not drop off and battery voltage goes beyond 15 volts, the rectifier-regulator is defective, because it is allowing an overcharge.

If, however, the ammeter reading indicates a 15 amp output, but the battery voltage will not come up to 13.8 volts, the battery or connections are defective.

If the ammeter reading indicates less than 15 amp output before the battery reaches 13.8 volts, either the rectifier-regulator or the alternator-stator is defective. Test the alternator-stator to determine if either or both are defective.

C. Test the Alternator-Stator

REPAIR

Replacing Alternator-Stator

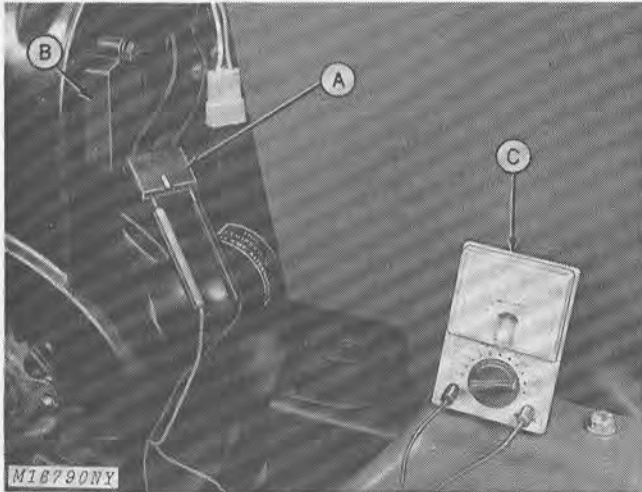

A—Coupler B—Rectifier-Regulator C—AC Voltmeter

Fig. 5-Testing Alternator Stator

To test the alternator-stator, unplug the coupler (A) at the rectifier-regulator (B). Connect an AC voltmeter (C) across the AC terminals in the coupler as shown in Fig. 5.

Run the engine at full throttle. Voltage reading should be at least 28 volts. If less than 28 volts, alternator-stator is defective.

D. Test Circuit Breaker

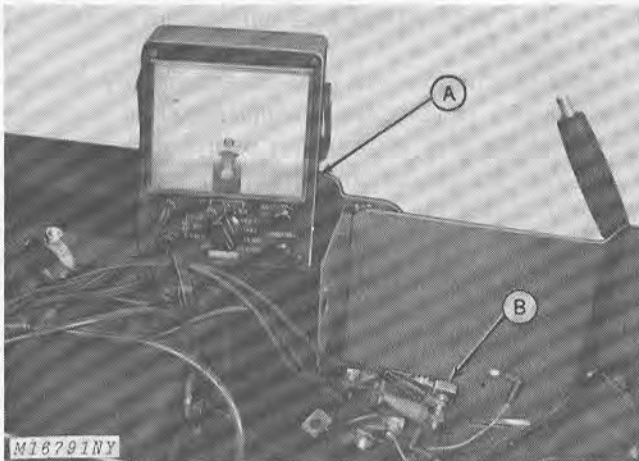

A—Ohmmeter B—Circuit Breaker

Fig. 6-Testing Circuit Breaker

To test for a defective circuit breaker (B), use an ohmmeter (A), Fig. 6. If an ohmmeter is used, a good circuit breaker will show zero resistance.

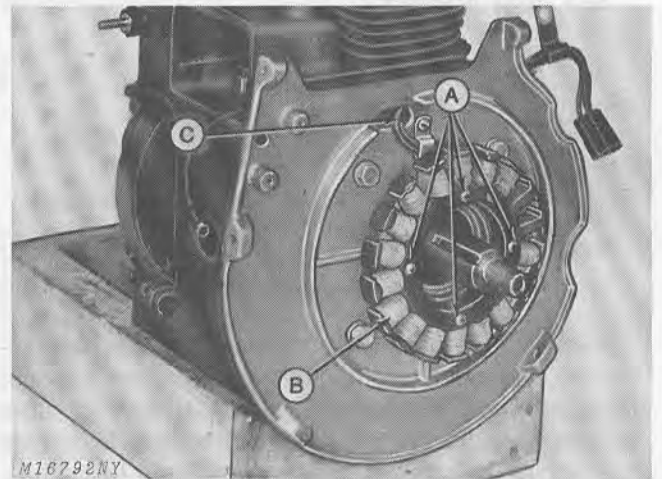

A—Screws B—Stator C—Wires

Fig. 7-Removing Alternator-Stator

If AC voltage test proved alternator-stator defective, replace it as follows:

Remove blower housing and flywheel.

Disconnect stator wires (C) from clip and 3-terminal coupler, Fig. 7. Remove four screws (A) securing stator (B) to bearing plate and remove stator.

Reverse above procedure for installation.

Group 25 LIGHTS

DESCRIPTION

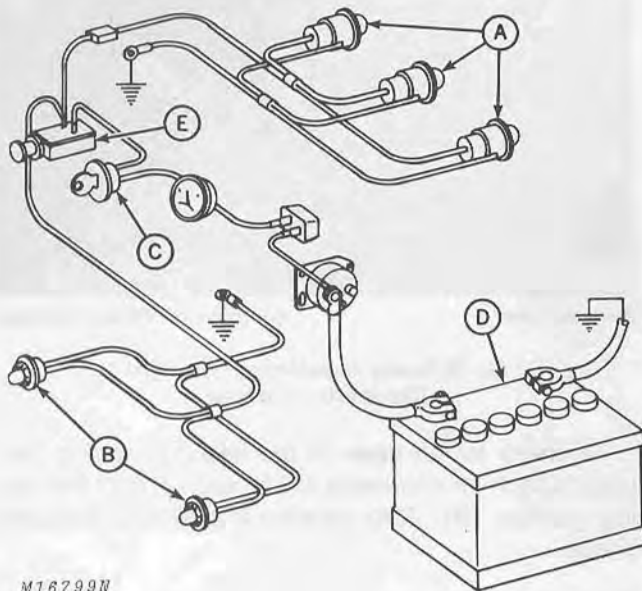

M16799N

A—Headlights C—Key Switch E—Light Switch
B—Taillights D—Battery

Fig. 1-Lights and Wiring

All 200 Series Tractors are equipped with headlights as standard equipment. There are three headlights with a single lense mounted onto the hood. Some tractors are equipped with taillights mounted at the rear of the fender-deck. Bulbs can be replaced quickly and easily without removing the lenses.



M16793NY

Fig. 2-Removing Headlight Bulb

To remove headlights, turn socket 1/8-turn to the left, then remove bulb from socket by pushing down on the bulb and turning it 1/4-turn to the left.



M16794NY

Fig. 3-Removing Taillight

To remove the taillights, turn socket 1/4 turn toward the right, then pull bulb straight out of socket.

DIAGNOSING MALFUNCTIONS

PROBLEM	CAUSE
Dim Lights.	High resistance in circuit or poor ground on lights.
	Low battery charge.
	Defective light switch or starter switch.
Lights Burn Out Prematurely	Excessive voltage due to faulty regulator or ground wire on alternator.
	Wrong type bulb being used.
Lights fail to work.	Defective socket or bulb.
	Broken wire or disconnected coupler.
	Corroded connections.
	Switch failure.

TESTING

Visual Inspection

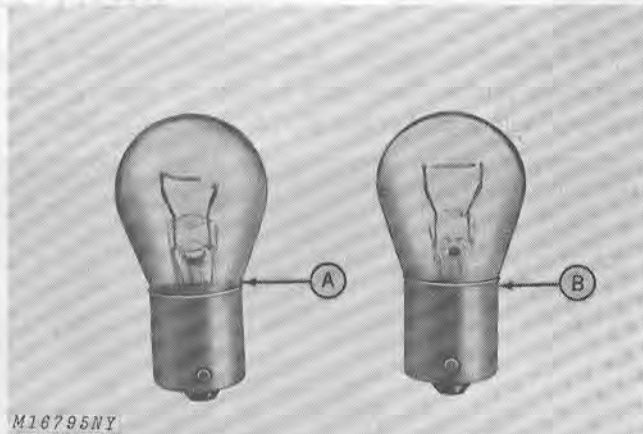

A—Defective Bulb

B—Good Bulb

Fig. 4—Light Bulbs

Make a visual inspection of connections, wiring harness, sockets and bulbs.

A good bulb will be clear, while a burned bulb may be dark. Bulb is defective if the filament wire is broken.

Wiring Harness

There are three typical ways a wiring harness may fail: An open (break), ground or a short. An ohmmeter can be used to check for these conditions. The chart below tells you how to test for these failures.

- | | |
|--|---|
| <p>A. Test for Open
(Broken Wire)</p> | <p>An ohmmeter will show an infinite resistance when connected to the ends of the harness, and an infinite resistance from the harness to ground or adjacent wires.</p> |
| <p>B. Test for Ground
(Bare Wire Touching Frame or Ground)</p> | <p>An ohmmeter will show zero resistance from wire to ground. It may or may not show resistance to the ends of the wiring harness. Look for a blown fuse or tripped circuit breaker.</p> |
| <p>C. Test for Short
(Rubbing of Two Bare Wires)</p> | <p>To check for a short, attach an ohmmeter to the ends of different wires in the wiring harness. If the wires are rubbing, the ohmmeter will show zero resistance. When checked with a voltmeter both wires will show voltage.</p> |

Litho in U.S.A.



A—Ohmmeter

B—Ends of Wiring Harness

Fig. 5—Testing Resistance in Headlight Circuit with Ohmmeter

To check for an open in the headlight wiring harness, attach an ohmmeter (A) to each end of the wiring harness (B). Zero resistance indicates a closed circuit.

Switches

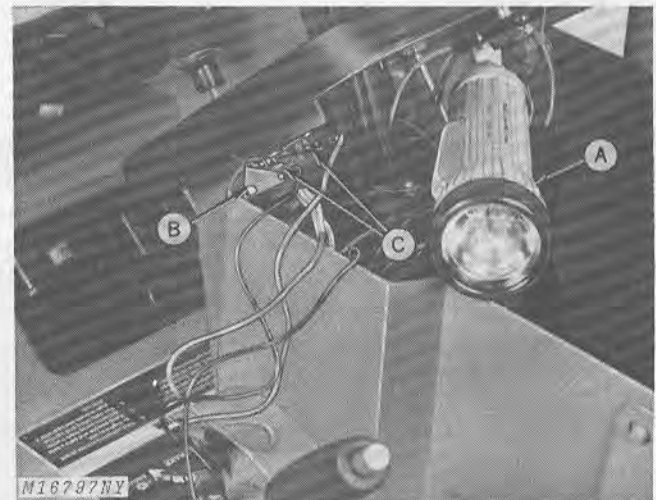

A—Test Light

B—Switch

C—Switch Terminals

Fig. 6—Testing Light Switch

To test the light switch (B), Fig. 6, connect a test light (A) to the switch terminals (C).

With the switch (B) in the "ON" position, the test light (A) will glow. With the switch (B) in the "OFF" position, the test light (A) should go out.

To test the ignition switch, see page 40-15-5.

Group 30 ELECTRIC LIFT

PRINCIPLE OF OPERATION

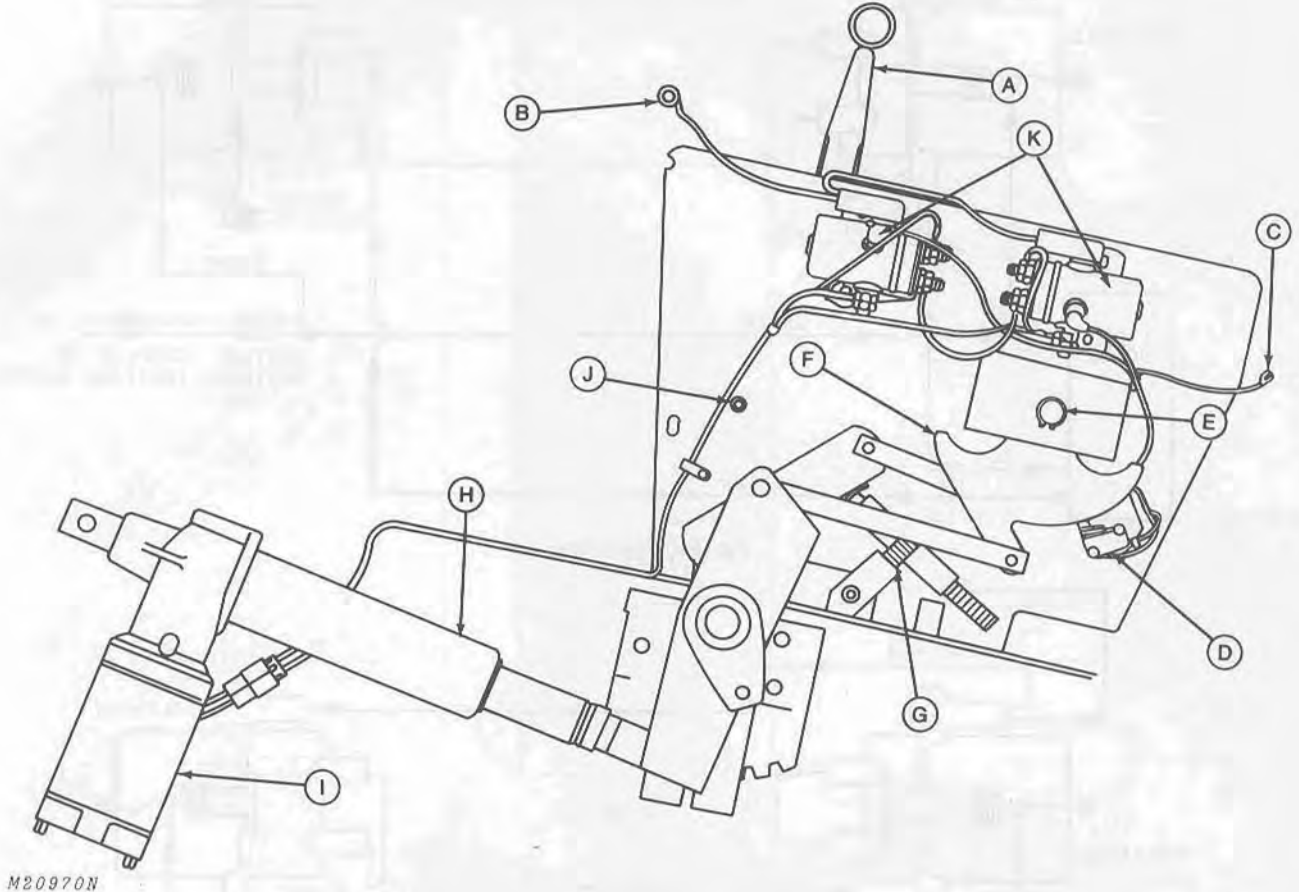

A—Lift Lever
B—Lead to Battery
C—Lead to Ignition
D—Control Switches

E—Pivot Shaft
F—Cam
G—Depth Control
H—Lift Actuator

I—Lift Motor
J—Stop Spacer
K—Solenoids

Fig. 1—Electric Lift Components

The electric lift is available for all 200 Series Tractors.

Current from the ignition switch is directed to two control switches (D) attached to the lift lever quadrant. As the lift lever (A) is moved, the switches (D) are pivoted against a cam (F) linked to the lift actuator (H) which pivots on the same axis as the switches. As the switches are moved against the cam (F) one switch will close. The current then flows through

the switch to one of the two solenoids (K) that control the direction of current flow through the lift motor (I).

The motor (I) will operate until the cam (F), linked to the lift actuator (H) returns to a neutral position at the control switches.

CIRCUITS

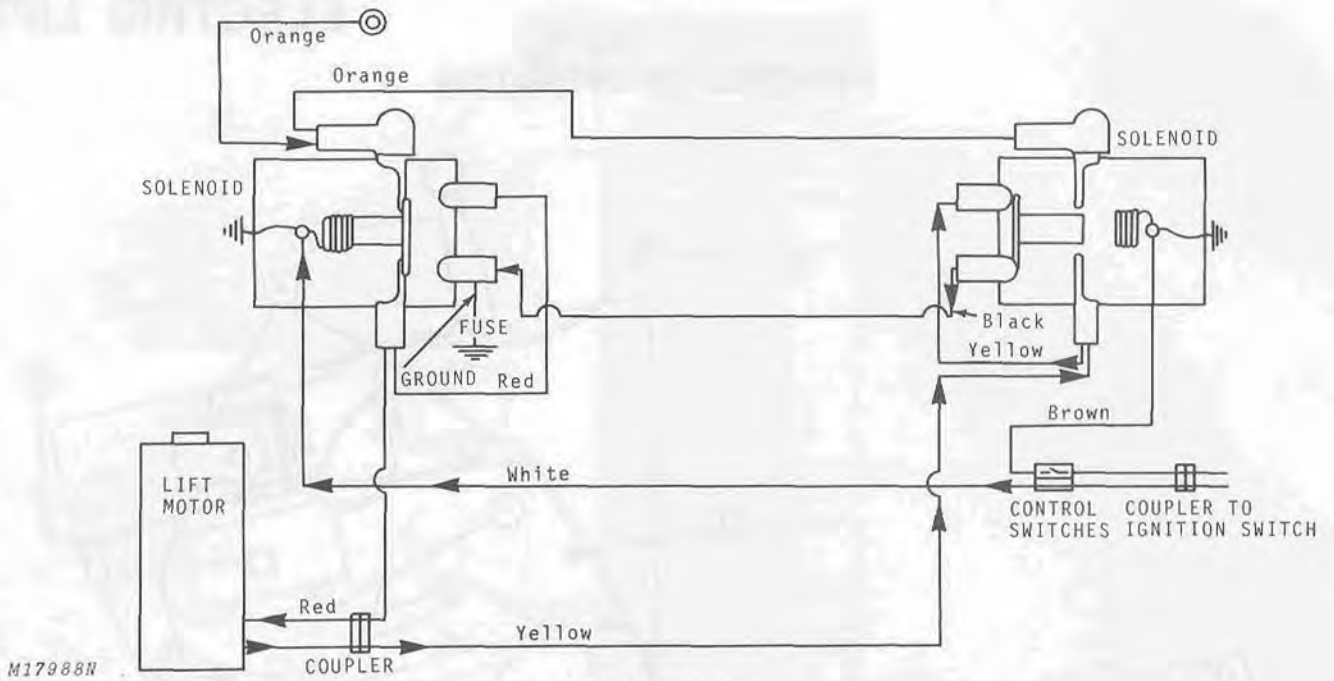

Fig. 2-Current Flow

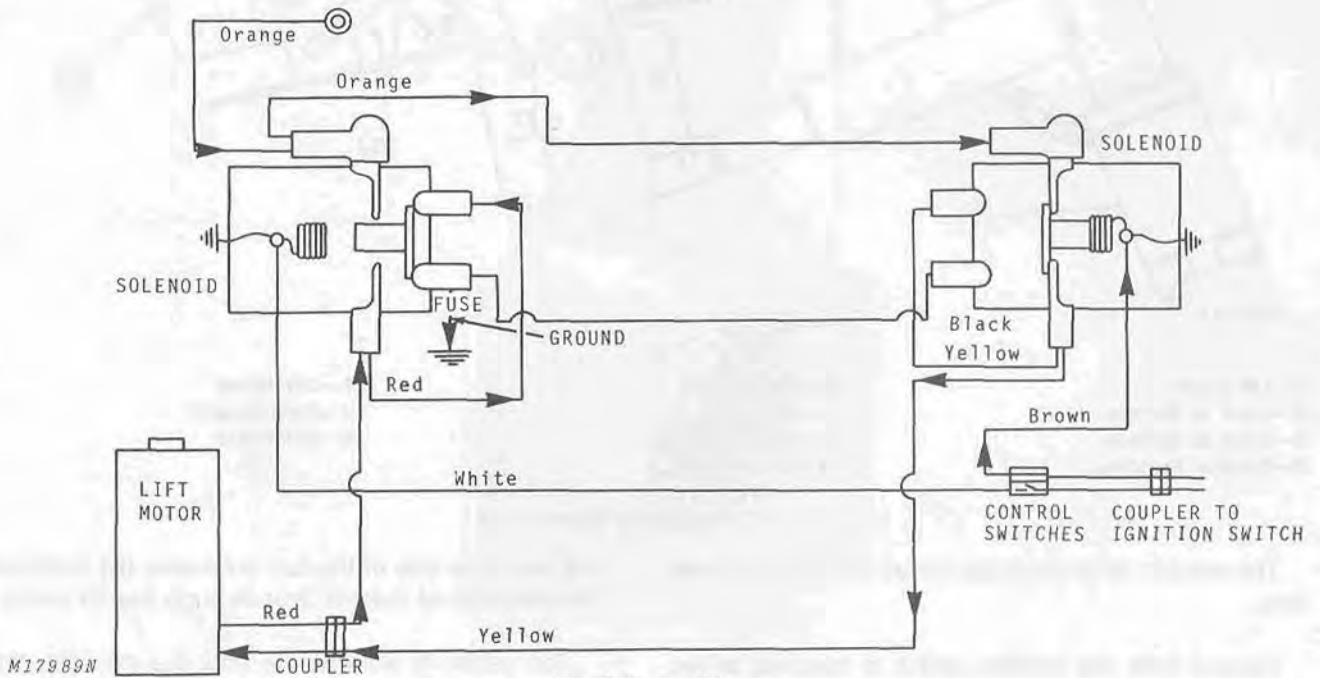

Fig. 3-Current Flow

By changing the direction of current flow through the lift motor, the lift may be raised or lowered.

The diagrams above show the two directions of current flow through the lift motor.

To raise the lift, pull the lift lever to the rear. The lift lever quadrant attached to the switch arm rotates the switches against the cam. One switch closes as it is rotated against the raised cam surface.

As the switch closes, a solenoid is activated. Current is directed through one motor lead through the motor to the solenoid which is not activated and to ground.

To lower the lift, push the lever forward. The switches are rotated against the cam in the opposite direction. This closes the other switch activating its solenoid. Current is directed through the lift motor in the opposite direction and to ground, changing the direction the motor operates.

DIAGNOSING AND TESTING

1. Lift does not operate.

Check fuse

Fuse Blown

Make Test A - Visually check wiring, connections and components—
Page 40-30-4
(Check solenoids)

Remove and inspect lift motor—
Page 40-30-9

Test D—Test lift actuator assembly—
Page 40-30-4

Fuse Not Blown

Make Test A - Visually check wiring, connections and components—
Page 40-30-4

Make Test B - Check voltage to solenoids—Page 40-30-4

Make Test C - Test Solenoid—Page 40-30-4

Inspect for binding linkage.

Make Test E - Check voltage to switches—Page 40-30-5

Make Test F - Check cam arm side play on lift having welded cam and switch arms—Page 40-30-5

Make Test G - Check switch spacing on lift having welded cam and switch arms—Page 40-30-5

Check cam and/or switch adjustment—
Page 40-30-7

Make Test I - Test motor—
Page 40-30-6

2.

Lift operates intermittently—
Motor thermo-overload switch trips.

Working lift rapidly with heavy load.

Check lift stop adjustment—Page 40-30-6

Check for binding lift linkage.

Check cam and or switch adjustment on lifts having welded cam and switch arms—Page 40-30-7

Inspect lift motor or activator drive—
Pages 40-30-9, 40-30-12

3.

Lift will not hold load in raised position or lift oscillates between raising and lowering.

Worn brake spring in activator—
See page 40-30-12

4.

Lift operates only short distance.

Check cam and/or switch adjustment on lifts having welded cam and switch arms.

Check for binding lift linkage.

DIAGNOSING AND TESTING—Continued

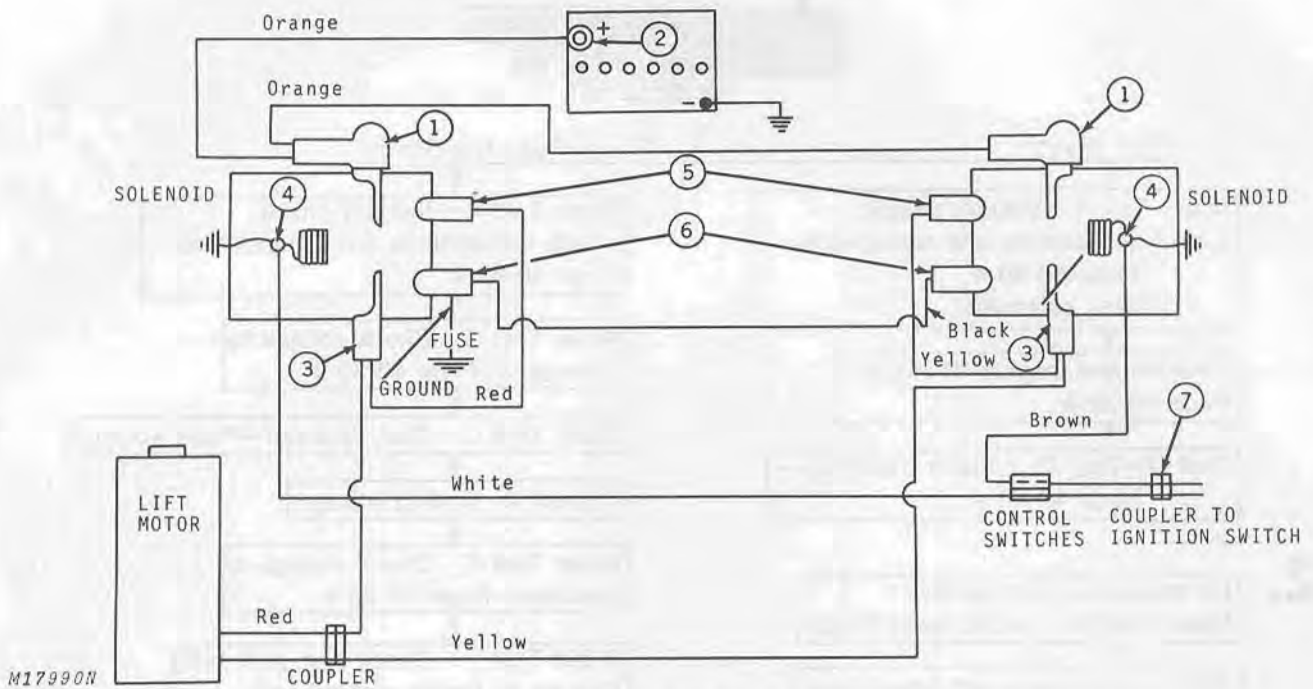

Fig. 4—Electric Lift Circuit Test Points

Test A - Make a Visual Check

Make a visual check of all wires and connections. Check for loose or corroded connections, poor contacts at grounds or damaged components.

Test B - Check Voltage to Lift System

Check for voltage to the positive lead at test point 1, Fig. 4.

Test C - Test Solenoid

Test solenoid by connecting test light between test points 1 and 3, Fig. 4. Remove the lead at the solenoid from the control switches at test point 4. Energize solenoid by connecting jumper lead from the positive battery post to test point 4, Fig. 4.

If the test light does not light, either the solenoid is not grounded or it is defective. If defective, replace solenoid.

NOTE: If the solenoid is defective, adjust lift stop after replacing solenoid, page 40-30-6.

If the test light lights, test the two terminals of the solenoid at test points 5 and 6.

To test, disconnect the jumper lead from the battery to test point 4. Then connect a test light between test points 5 and 6 on the solenoid being tested. The light should light.

Test D - Test Lift Actuator Assembly

IMPORTANT: Disconnect black lead from one of the solenoids at test point 6.

To test, connect a jumper lead from the red wire at test point 5 to test point 2 at the battery. Also connect a jumper lead from the yellow wire at test point 5 to the negative battery post. The motor should operate the lift upward.

Reverse the jumper leads, that is connect the jumper lead from the red wire to the negative battery post and the jumper lead from the yellow wire to test point 2 at the battery, Fig. 4. This should operate the lift downward.

If the lift does not operate,

Inspect the leads from the solenoids to the lift motor.

Check the actuator linkage for binding or bent linkage.

Remove and inspect the actuator assembly.

Test E - Test Switch Voltage

To test switch voltage, connect a voltmeter between test point 7 and ground, Fig. 4. Turn the ignition switch to the "RUN" position. If voltage is observed, check further as follows:

Remove lift panel (left-hand pedestal side) from tractor. Inspect leads and connectors at switches.

Test for defective switches, test H.

Check cam adjustment on lifts having welded cam and switch arms, page 40-30-7 and 40-30-8.

If no voltage is observed, inspect for a defective lead to the key switch. Inspect the key switch, page 40-10-6.

Test F - Check Cam Arm Side Play

(For electric lift units having welded cam and switch arms only)

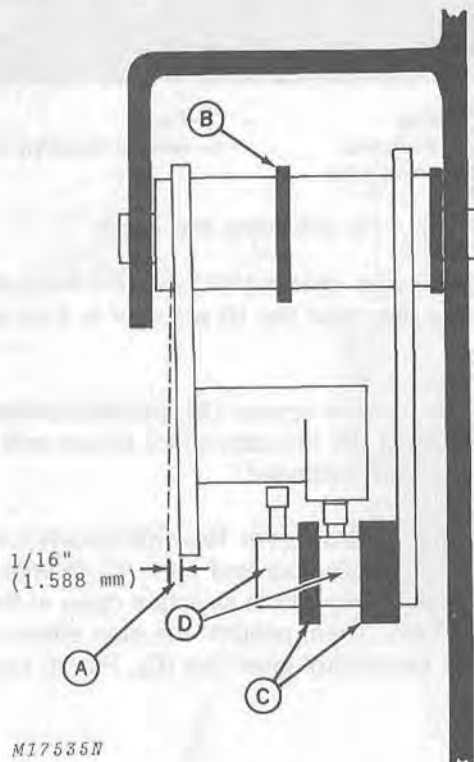

A—Cam Arm Side Play
B—Shim Washers
C—Switch Spacers
D—Switches

Fig. 5-Cam and Switches (Front View)

Check cam arm side play (A), Fig. 5. If side play exceeds 1/16 inch (1.588 mm), add shim washers (B).

Test G - Check Switch Spacing

(For electric lift units with welded cam and switch arms only)

Remove the lift panel (left-hand pedestal side) from tractor. Count the switch spacers (C), Fig. 5. If there is only one spacer, install AM36200 spacer kit which includes two spacers.

Test H - Test Switches

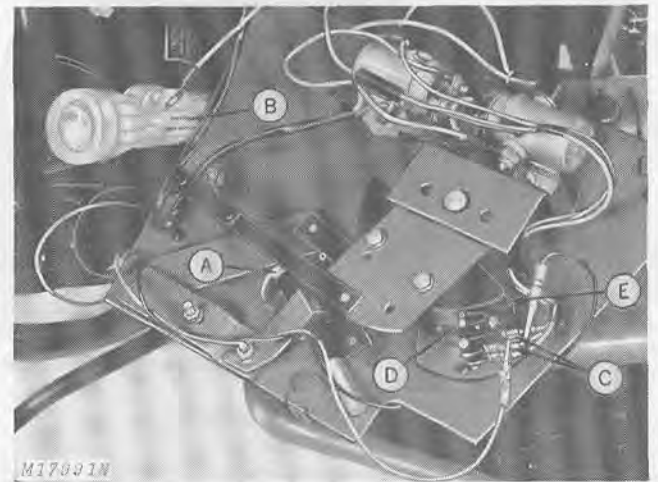

A—Depth Control
B—Test Light
C—Switch Terminals
D—Switch Roller
E—Cam

Fig. 6-Testing Control Switches

Remove left-hand pedestal side as shown in Fig. 6. Move side panel depth control (A) until it is in lowest position, Fig. 6.

Position the control lever half-way between full forward and fully back.

Connect test light (B) to the terminals (C) of one switch. Rotate the cam (E) against the switch roller (D) through the complete range of travel.

The test light should light as the switch roller rides on the raised surface of the cam. If the switch is not closing (light does not light) when on the raised surface of the cam, adjust the switches.

If the switch closes and the test light does not light, replace the switch.

If the switch sticks momentarily in the closed position, replace the switch.

(For electric lift units having welded cam and switch arms)

If the test light lights through only part of the rotation against the raised surface of the cam, adjust the cam, pages 40-30-7 and 40-30-8.

Test I—Test Lift Motor

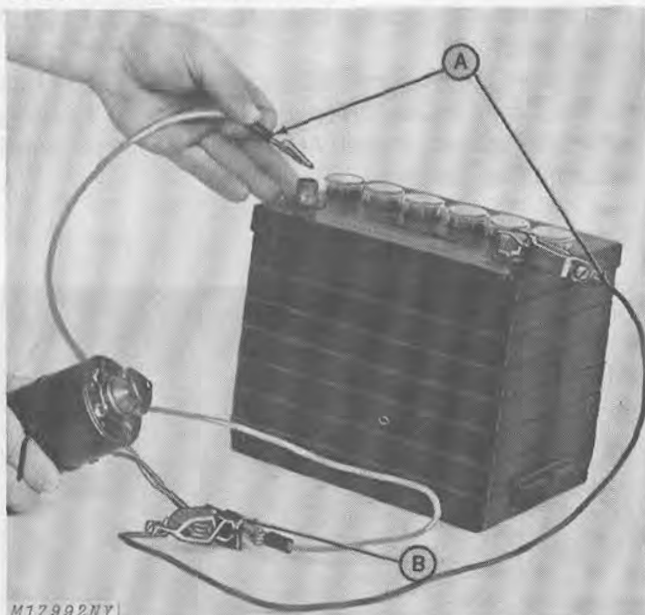

A—Test Wires

B—Drive Motor Coupler

Fig. 7-Testing Lift Motor

To test drive motor, remove motor from tractor and attach wires (A) to each of the terminals on the drive motor coupler (B), Fig. 7. Attach one wire to the positive battery post and the other wire to the negative battery post. The motor shaft should rotate. Reverse the wires on the battery and the motor should rotate in the opposite direction. If the motor fails to rotate in either direction, replace it.

ADJUSTMENTS

Depth Control Adjustment



A—Console Depth Control
B—Depth Stop

C—Deck Depth Control

Fig. 8-Adjusting Console Depth Control

Turn the deck depth control (C) counterclockwise as far as possible. This allows the console depth control (A) to be used to set attachment depth.

To adjust the console depth control (A), lower the attachment to the desired height. Turn the console depth control (A) until the depth stop (B) touches the lift mechanism, Fig. 8.

Stop Spacer Adjustment



A—Stop Spacer

B—Control Switches

C—Control Lever Link

D—Cam

E—Neutral Position on Cam

Fig. 9-Adjusting Stop Spacer

Adjust the stop spacer (A) to prevent the solenoids from energizing after the lift actuator is fully extended.

To adjust, loosen spacer (A), pull the control lever back and allow the actuator motor to run until the lift actuator is fully extended.

Push the control lever forward slowly until the switch (B) just activates and cam (D) returns to the neutral position (E) - both switches open at the center of the cam. Then, position the stop spacer (A) so it touches the control lever link (C), Fig. 9, and tighten.

Lift Lever Tension Adjustment

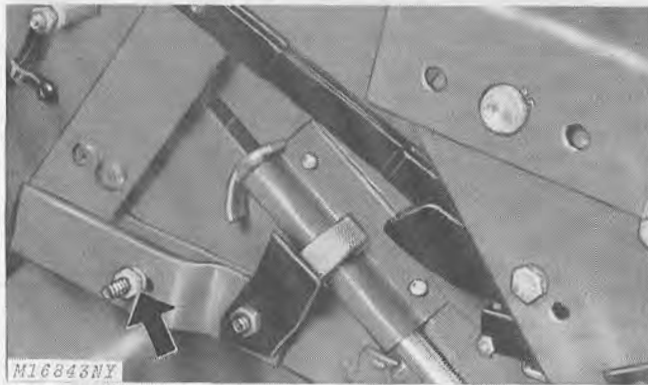
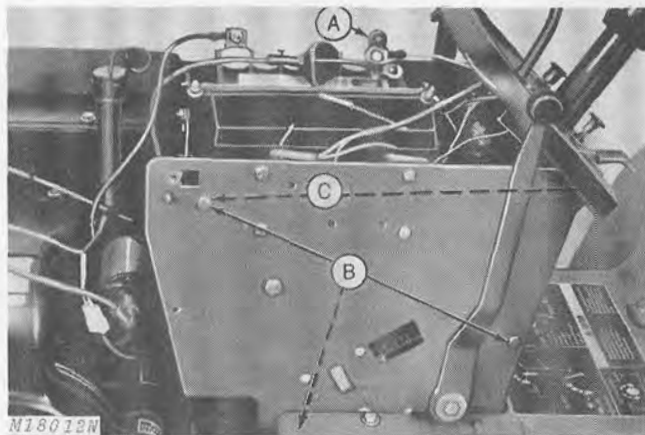

Fig. 10-Adjusting Lift Lever Tension

To adjust lift lever tension, tighten or loosen the lock nut inside the pedestal on the lever brake until desired tension is achieved, Fig. 10.

Cam and Control Switch Adjustment

Make sure the cam is adjusted correctly before adjusting the control switches.



A—Lead B—Bolts C—Nuts

Fig. 11-Removing Pedestal Side

Remove lead (A) from positive battery terminal. Remove three bolts (B) and two nuts (C) from left-hand pedestal side, Fig. 11.

Refer to Fig. 12 and slide link (C) off of pivot (F).

Lower pedestal side onto fender-deck.

Cam Adjustment

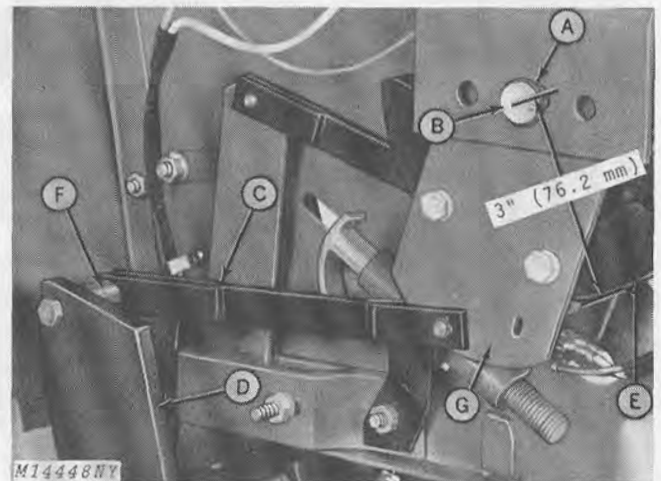

A—Snap Ring D—Lift Quadrant G—Arm
B—Pivot Shaft E—Cam
C—Cam Link F—Pivot

Fig. 12-Removing Cam

The cam (E) on the electric lift controls the closing of the control switches.

The cam (E) should be adjusted for a 3-inch (76.2 mm) radius from center of pivot shaft (B) to raised surface of cam (E). This requires a JDM-65 Essential Service Tool.

Remove snap ring (A) from pivot shaft (B) and remove pivot shaft. Remove cam (E), arm (G), and cam link (C) as an assembly.

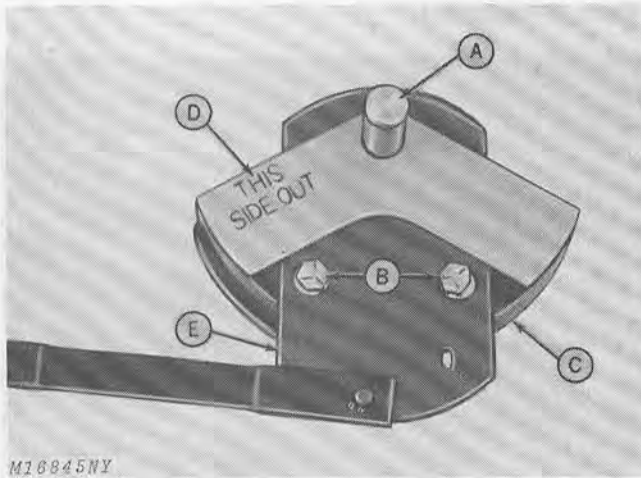

A—Pivot Shaft C—Cam E—Arm
B—Cap Screws D—JDM-65 Tool

Fig. 13-Adjusting Cam

Insert pivot shaft (A) through arm (E), Fig. 13.

Loosen two cap screws (B).

Place JDM-65 Essential Service Tool (D) on pivot shaft (A) and adjust edges of cam (C) up to edge of tool (D).

Tighten cap screws (B) and recheck cam adjustment with tool (D).

NOTE: A true radius is necessary for dependable operation and to avoid damage to the control switches.

After adjustment, reinstall cam and arm assembly with pivot shaft (B), Fig. 12 through pedestal side. Secure with snap ring (A), Fig. 12.

On lifts with one piece cam and arm, cam adjustment is not necessary.

Control Switch Adjustment

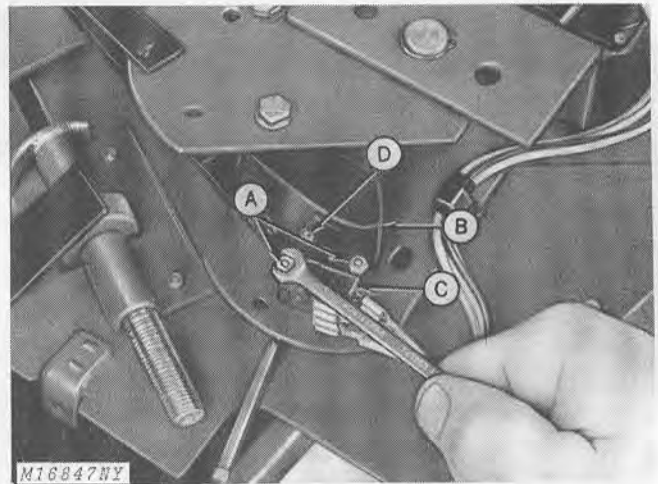

A—Nuts B—Cam C—Switches D—Plunger

Fig. 14-Adjusting Switches on Lifts Having Welded Cam and Switch Arms

Loosen nuts (A), on switches (C) at one end of cam (B) move the switches into the cam until one switch closes.

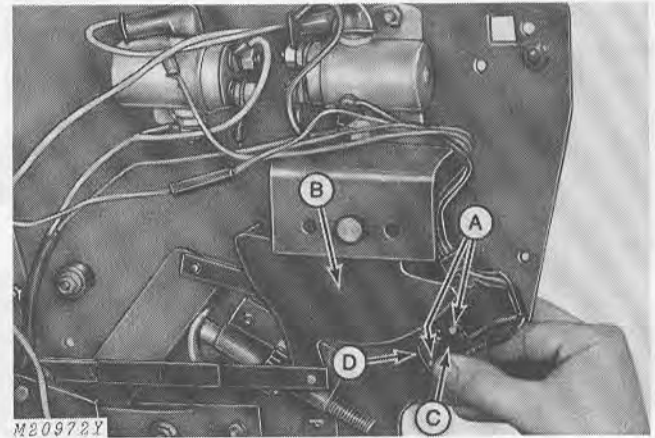

A—Screws B—Cam C—Switches D—Plunger

Fig. 15-Adjusting Switches on One Piece Cam and Switch Arms

Loosen screws (A) on switches (C) at one end of cam (B) move the switches into the cam until one switch closes.

DISASSEMBLY AND REPAIR

Removing Actuator Assembly

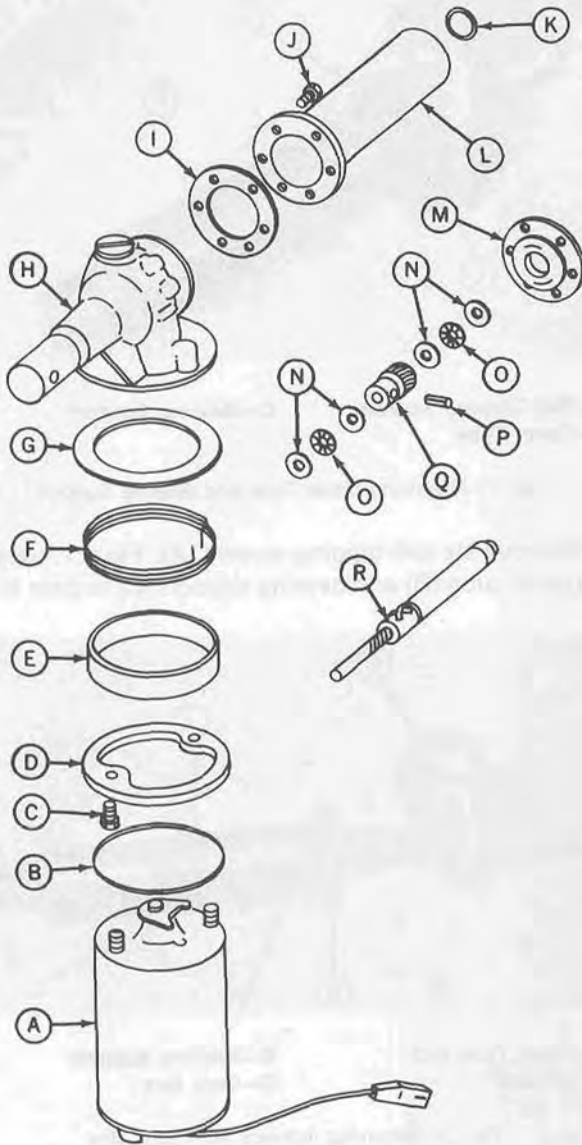

M16848N

- | | |
|----------------|-------------------|
| A—Motor | J—Screw |
| B—O-Ring | K—O-Ring |
| C—Screw | L—Tube |
| D—Adapter | M—Support |
| E—Spacer | N—Thrust Washers |
| F—Brake Spring | O—Thrust Bearings |
| G—Gasket | P—Pin |
| H—Gear Box | Q—Gear |
| I—Gasket | R—Ball Screw |

Fig. 16-Lift Actuator Assembly

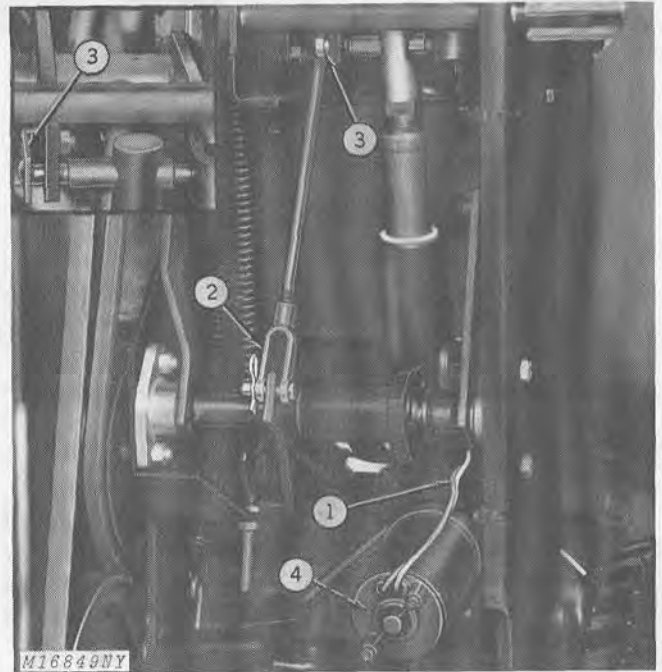

Fig. 17-Removing Actuator Assembly

1. Unplug drive motor at connector.
2. Disconnect secondary lift shaft at the threaded clevis end.

NOTE: Remove bolts securing secondary lift shaft. This will allow clearance for installation of actuator.

3. Remove offset pin from primary lift arm.
4. Remove cotter pin and washer from pivot pin, and remove actuator assembly.

Removing Electric Motor

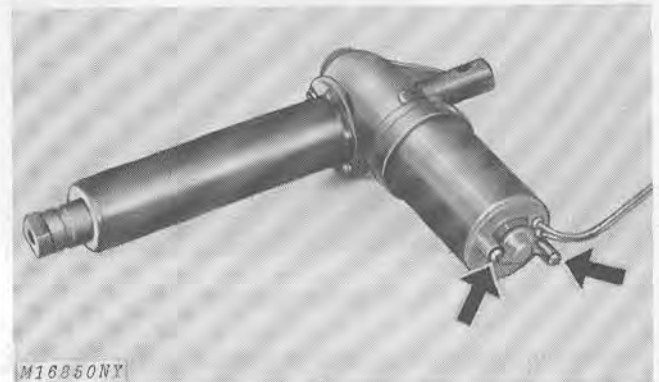
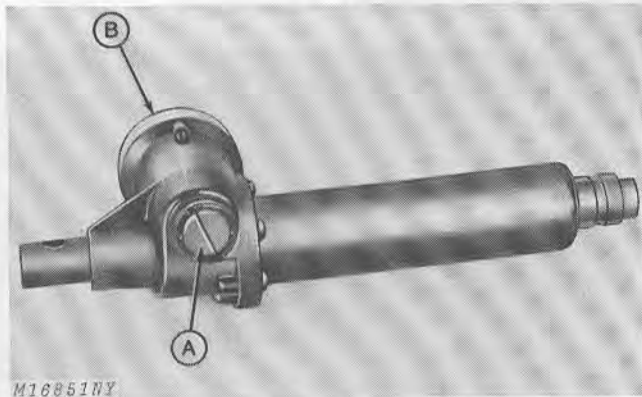

Fig. 18-Removing Motor from Actuator

Remove two thru bolts (arrows) securing motor to actuator, Fig. 18.

NOTE: There are no service procedures for the motor. If it does not function as explained under "Test 1," page 40-30-6, replace the motor.

Removing Gear Box



A—Large Screw

B—Motor Adapter

Fig. 19-Worm Gear Screw

Do not attempt to replace the worm gear in the gear box. This gear is preloaded during factory assembly and the large screw (A), Fig. 19, is staked in place to maintain the proper end play. If the worm gear is damaged, replace the gear box.

To replace brake spring in gear box, use AM34885 Brake Spring and Spacer Kit. See page 40-30-12.

Remove two socket-head screws securing motor adapter (B) to gear box. Remove adapter and gasket.



Fig. 20-Removing Spacer

Use a screwdriver to remove spacer (arrow), Fig. 20, and then remove brake spring.

Removing Cover Tube and Actuator

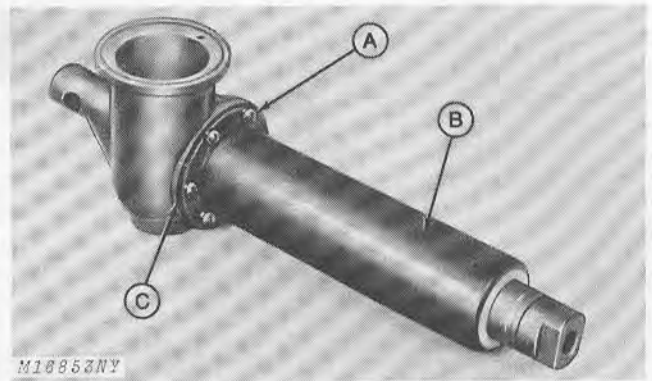

A—Self-Tapping Screws
B—Cover Tube

C—Bearing Support

Fig. 21-Removing Cover Tube and Bearing Support

Remove six self-tapping screws (A), Fig. 21, securing cover tube (B) and bearing support (C) to gear box.

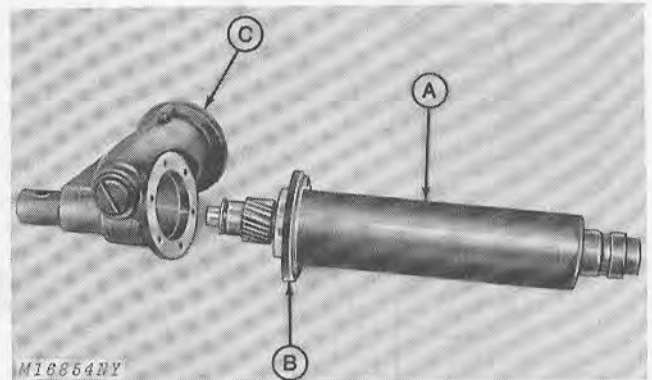

A—Cover Tube and Actuator

B—Bearing Support
C—Gear Box

Fig. 22-Removing Actuator from Gear Box

Remove cover tube with actuator (A) and bearing support (B) from the gear box (C), Fig. 22.

Pull the cover tube with O-ring and gasket off the actuator. The bearing support stays with the actuator and gear.

NOTE: The O-ring located in the nylon bushing is replaceable. If the nylon bushing is damaged, replace cover tube. The gear, two thrust washers, four plain washers and bearing support are replaceable.

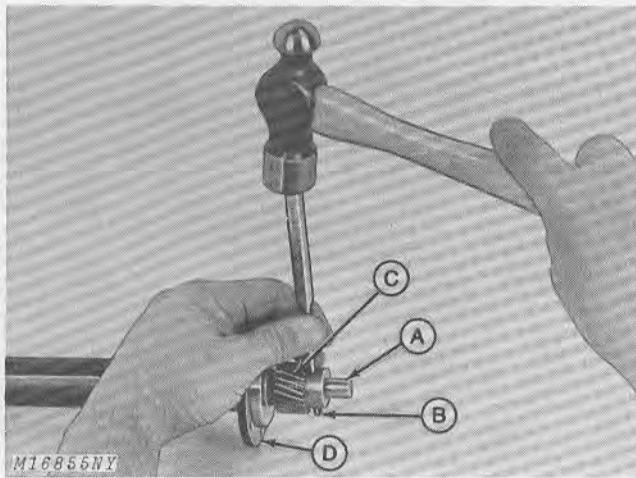

A—Actuator Shaft
B—Groove Pin
C—Gear
D—Bearing Support

Fig. 23-Removing Gear from Actuator Shaft

Remove two washers and thrust bearing from end of actuator shaft (A). Use a drift punch and drive out the groove pin (B), Fig. 23, securing gear (C) to shaft. Remove gear (C), two washers, thrust bearing and bearing support (D) from shaft.

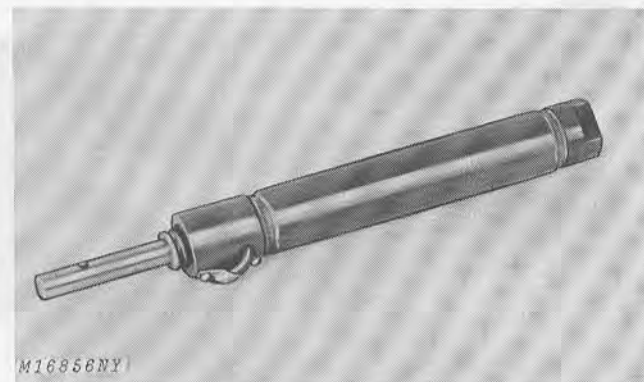
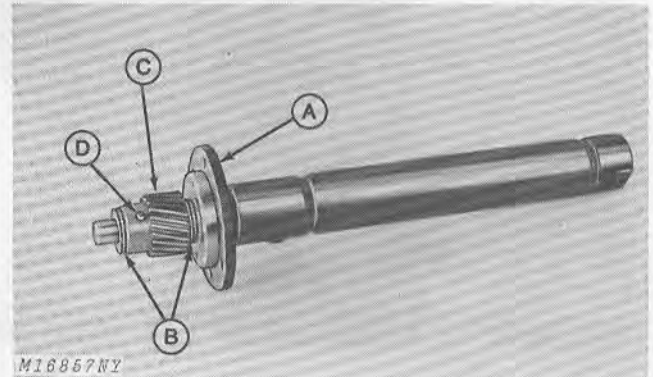

Fig. 24-Actuator Shaft

The actuator shaft, Fig. 24, is not serviceable. Any damage to this part requires complete replacement.

ASSEMBLY

Assembling Cover Tube and Actuator



A—Bearing Support
B—Washers, Thrust Bearing and Washers
C—Gear
D—Groove Pin

Fig. 25-Actuator Assembly

Install bearing support (A), washers, thrust bearing and washers (B), and gear (C), Fig. 25. Secure gear to shaft with groove pin (D). Install washer, thrust bearing and washer (B) on the end of shaft, Fig. 25.

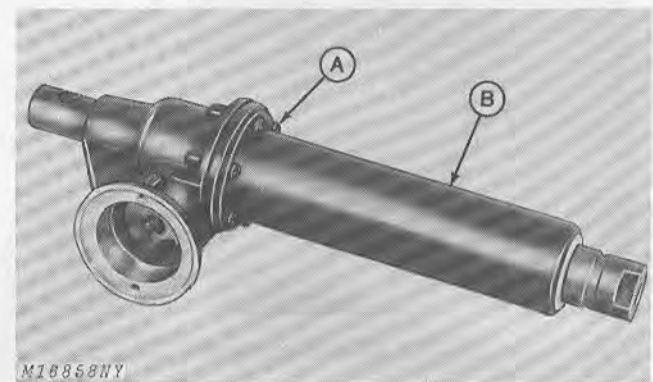

A—Self-Tapping Screws
B—Actuator

Fig. 26-Installing Actuator Assembly on Gear Box

Install new gasket and cover tube over actuator (B), Fig. 26.

Apply John Deere Multipurpose-Type Lubricant on O-ring and nylon bushing of cover tube.

Apply John Deere Multipurpose-Type Lubricant on end of actuator shaft and gear, and on worm gear in gear box.

Install actuator assembly (B) into gear box and secure with six self-tapping screws (A), Fig. 26.

Assembling Motor to Gear Box

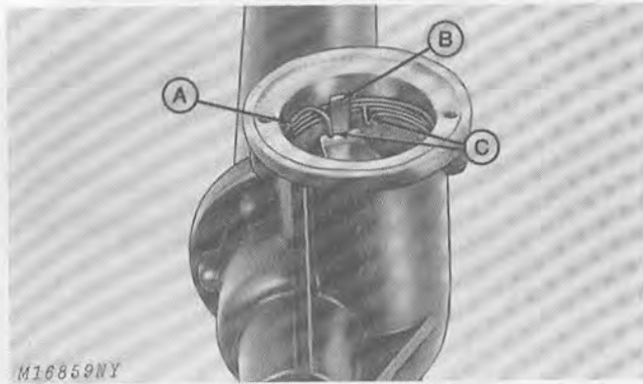

A—Brake Spring B—Shaft Leg C—Spring Prongs

Fig. 27-Brake Spring Installed in Gear Box

Lubricate outside of brake spring (A) lightly with John Deere Multipurpose-Type Lubricant. Install brake spring into gear box with leg (B) of shaft arm between prongs (C) of spring, Fig. 27.

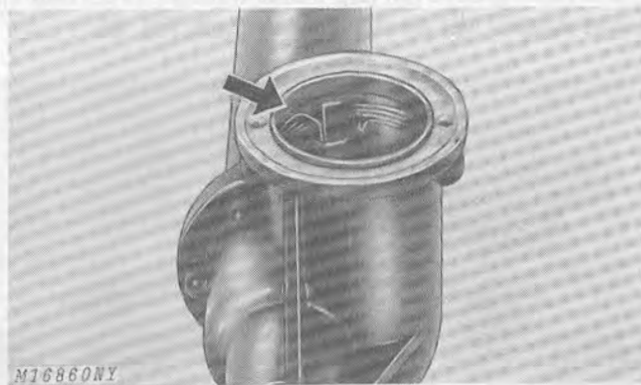
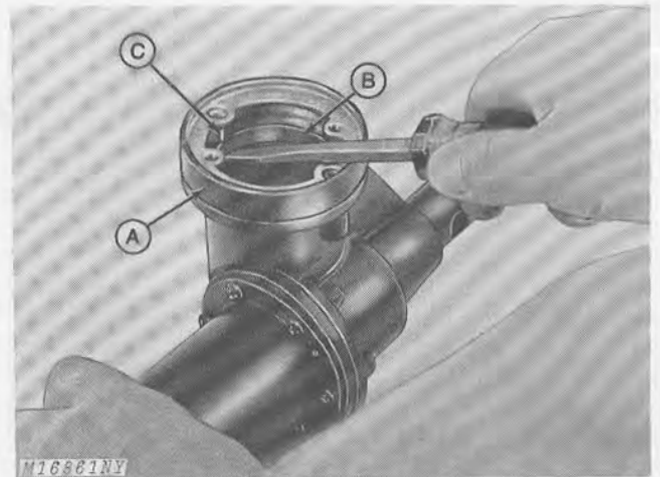

Fig. 28-Installing Spacer

Install spacer into gear box leaving spacer protruding slightly out of gear box, Fig. 28.



A—Motor Adapter B—Spacer C—Screw Hole Boss

Fig. 29-Positioning Spacer

Install motor adapter (A) with new fiber gasket and secure with socket-head screws.

Position a screwdriver across holes as shown in Fig. 29. Pry up on both sides of spacer (B) until it strikes screw hole boss (C) in motor adapter. Be sure coils of spring are in spring recess and the spring rotates freely.

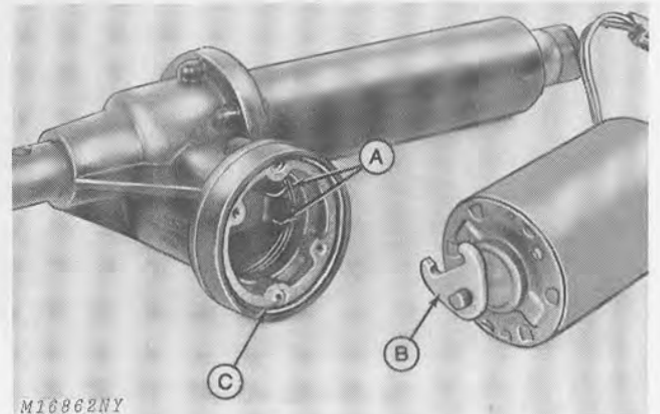

A—Spring Prongs B—Fork Bracket C—O-Ring

Fig. 30-Installing Motor to Motor Adapter

Install new O-ring (C) in motor adapter. Install motor on adapter with prongs of spring (A) positioned between forks of fork bracket (B) on motor shaft, Fig. 30. Tighten thru bolts securely.

INSTALLATION

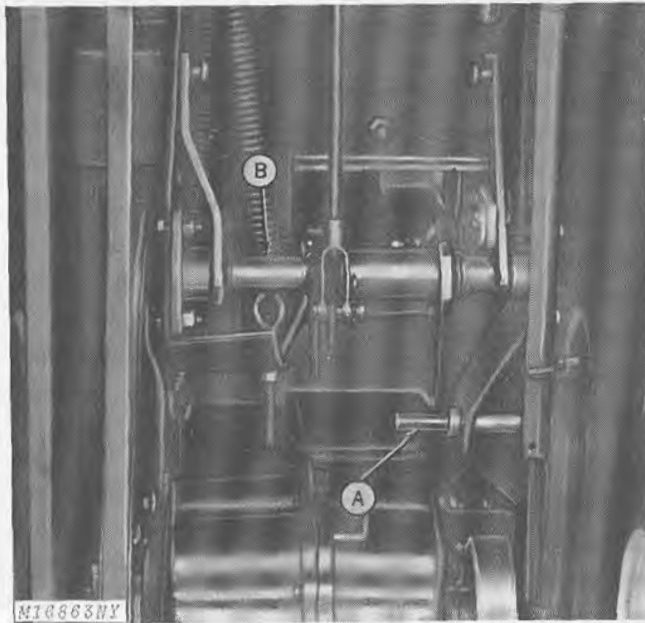

A—Pivot Pin B—Secondary Lift Shaft

Fig. 31-Installing Pivot Pin

Assemble actuator lift pivot pin (A) through anchor and frame holes. Secure pin (A) in place with two 1/8 x 1-1/4-inch cotter pins, Fig. 31.

NOTE: Remove bolts securing secondary lift shaft (B) in place. This will allow adequate clearance for installation of the actuator.

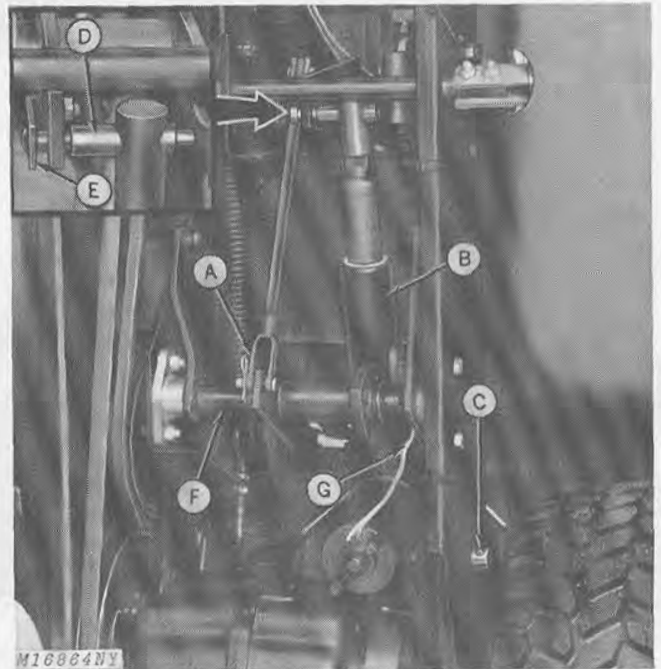

A—Threaded Yoke D—Spacer
B—Actuator E—Pin with Offset Strap
C—Pivot Pin F—Secondary Lift Shaft
G—Electrical Connector

Fig. 32-Installing Lift Actuator

Disconnect the secondary lift link at threaded yoke (A), Fig. 32.

Install rear part of actuator (B) on pivot pin (C). Secure the actuator to pivot pin (C) with a 17/32 x 13/16 x 0.060-inch flat washer and 1/8 x 1-1/4-inch cotter pin.

Manually rotate primary lift rearward. Assemble spacer (D), Fig. 32, through hole in ram (operating end) of actuator (B). Insert pin with offset strap (E) through hole in primary lift arm and spacer (D) into hole in quadrant. Secure pin in place by bolting offset strap part of pin (E) to primary lift arm with a 5/16 x 7/8-inch cap screw, 0.060 x 11/32 x 11/16 flat washer and hex. nut.

Re-connect the threaded yoke (A) on the secondary lift link.

IMPORTANT: Stop on secondary lift shaft must be toward the front of the tractor, so lift arms raise slightly when attaching the secondary lift link.

Bolt secondary lift shaft (F) back in place.

Connect electrical connector (G) on motor.

Section 50

POWER TRAIN

Group 5

GENERAL INFORMATION

CONTENTS

	Page		Page
GROUP 5 - GENERAL INFORMATION		GROUP 20 - 4-SPEED TRANSAXLE	
Description	5-2	Principle of Operation	20-1
GROUP 10 - CLUTCH AND VARIABLE SPEED DRIVE		Gear Shift Pattern	20-2
Principle of Operation	10-1	Diagnosing Malfunctions	20-3
Preliminary Diagnosis of Malfunction	10-3	Disassembly	20-4
Diagnosing Malfunctions	10-4	Removing Transaxle	20-5
Repair	10-6	Opening Transaxle	20-6
Inspecting V-Belts	10-6	Removing Internal Components	20-6
Cleaning V-Belts	10-6	Disassembling Shift Lever	20-7
Replacing Primary V-Belt	10-6	Inspection and Repair	20-8
Replacing Secondary V-Belt	10-7	Assembly	
Removing Variator	10-8	Bevel Gear Differential	20-10
Disassembling Variator	10-9	Bearings	20-10
Inspecting Variator	10-10	Input Shaft and Gear	20-11
Assembling Variator	10-11	Idler Gear and Shaft	20-11
Installing Variator	10-12	Output Shaft and Gear	20-12
Adjustments		Shifter Components	20-12
Linkage Adjustment	10-13	Idler Gear, Pinion and Thrust Washer ..	20-14
Spring Adjustment	10-13	Reverse Idler Shaft and Gear	20-14
Belt Guide Adjustment	10-13	Reverse Idler, Idler Gear Assembly and	
Specifications	10-14	Spacer	20-14
GROUP 15 - BRAKES		Cluster Gear and Thrust Washer	20-15
Principle of Operation	15-1	Installing Differential	20-15
Diagnosing Malfunctions	15-1	Placing Cover on Case	20-16
Description	15-2	Installing Seals	20-16
Repair	15-3	Installing Axle Supports	20-17
Adjustment	15-4	Positioning Shifter Forks	20-17
		Assembling Shifter Lever	20-17
		Installing Transaxle	20-17
		Torque for Hardware	20-18
		GROUP 25 - PTO CLUTCH	
		Principle of Operation	25-1
		Diagnosing Malfunctions	25-1
		Repair	25-2
		Assembly	25-4
		Adjustments	25-5

DESCRIPTION

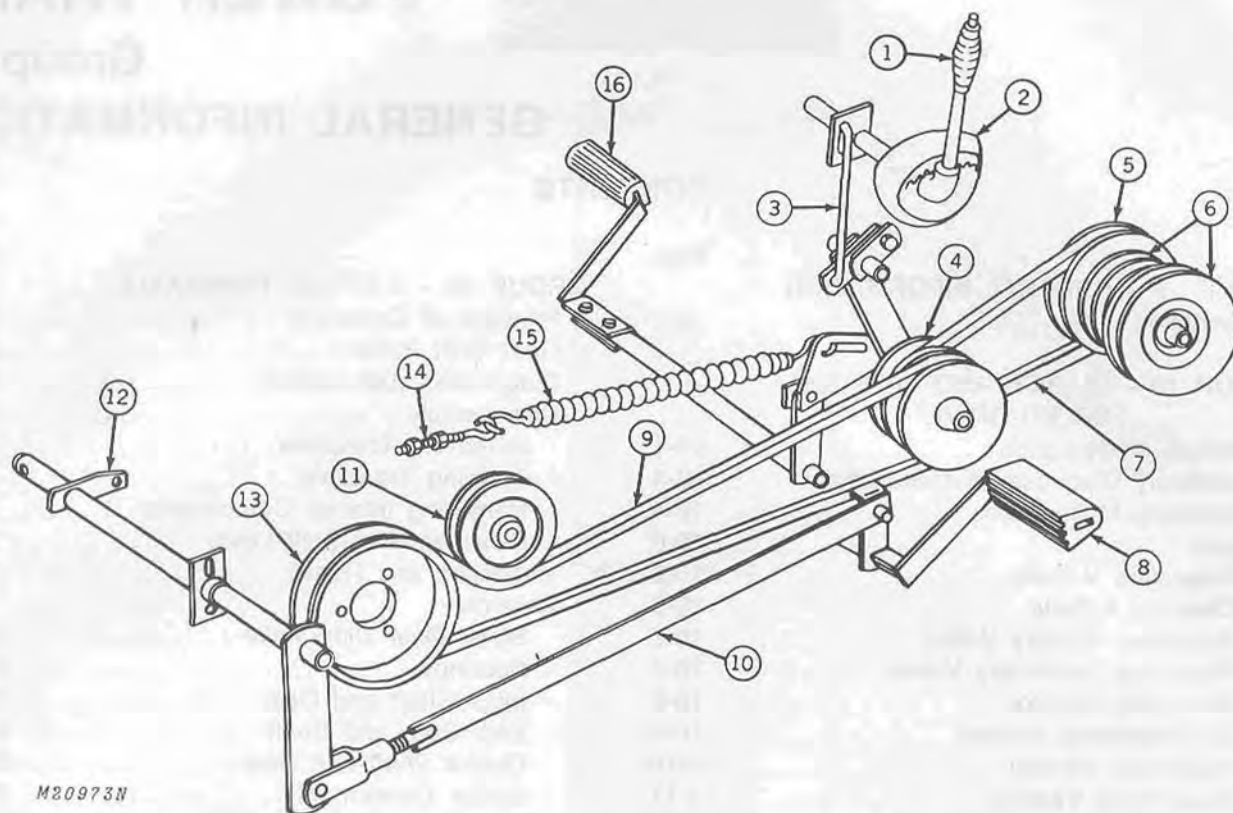

M20973N

- | | | | |
|-----------------------|-----------------------|------------------|------------------------------|
| 1—Speed Control Lever | 5—Engine Drive Sheave | 9—Secondary Belt | 13—Transmission Input Sheave |
| 2—Quadrant | 6—PTO Sheaves | 10—Brake Rod | 14—Eye Bolt |
| 3—Speed Control Link | 7—Primary Belt | 11—Idler Sheave | 15—Variator Spring |
| 4—Variator Sheave | 8—Brake Pedal | 12—Brake Lever | 16—Clutch Pedal |

Fig. 1—Power Train Components

The 200 Series Tractor power train consists of the following components: Engine drive sheave, variator sheaves, transaxle power input sheave, primary and secondary drive belts.

Forward speed of the tractor can be increased or decreased by moving the variable speed control lever forward or rearward. Speeds can be varied in conjunction with the 4-speed transaxle.

With the variable speed drive, changes in travel speed can be made without shifting gears.

The clutch and brake assembly operate independently of each other.

Refer to page 50-10-1 for a more detailed explanation of the clutch, brake and variable speed drive operation.

Group 10

CLUTCH AND VARIABLE SPEED DRIVE

PRINCIPLE OF OPERATION

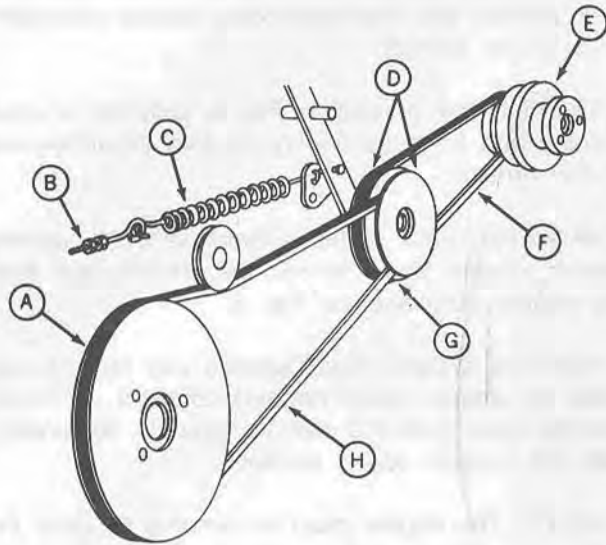

M16646N

- | | |
|-----------------|------------------|
| A—Driven Sheave | E—Drive Sheave |
| B—Eyebolt | F—Primary Belt |
| C—Spring | G—Center Sheave |
| D—Half Sheave | H—Secondary Belt |

Fig. 1-Variator Components

The variable speed drive is used in conjunction with the 4-speed transaxle and consists of two half sheaves (D) fixed to a common hub with a center sheave (G) free to slide on the shaft. This allows the working diameter of the variator sheaves to change sizes.

The variator is moved like a pendulum between the engine drive sheave (E) and transmission driven sheave (A). This in turn varies the speed and torque as it changes the working diameter of the variator sheaves.

The variator drive is draft load and torque sensitive. Load is sensed at the secondary belt (H). As the load is sensed, tension from the secondary belt (H) pulls it into the variator sheave. A spring (C) anchored to the variator arm and an adjustable eyebolt (B) on the frame allows adjusting the sensitivity of the variator by increasing or decreasing spring tension, page 50-10-13.

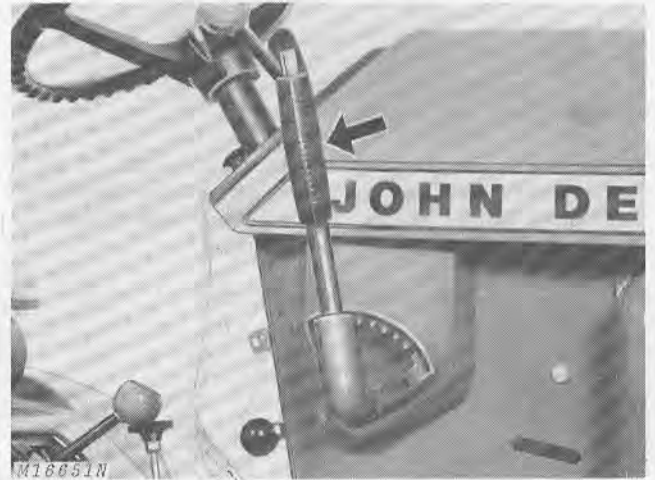
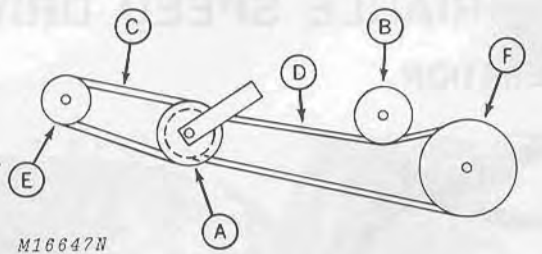

Fig. 2-Variable Speed Control Lever

The variable speed drive is regulated manually with the variable speed control lever, Fig. 2. By depressing the thumb release and moving the lever toward the front of the tractor, the variator is moved rearward and the tractor speed is increased. Moving the lever rearward moves the variator forward, decreasing tractor speed. Releasing thumb pressure on the lever locks the lever in any of seven speed positions on the quadrant.

NOTE: Only five positions are operative at any one time when the drive is properly adjusted. The other two positions allow for belt "tolerances" and normal wear before adjustment becomes necessary.

PRINCIPLE OF OPERATION—Continued



M16647N

- A—Variator
- B—Secondary Belt Idler
- C—Primary Belt
- D—Secondary Belt
- E—Engine Drive Sheave
- F—Transmission Driven Sheave

Fig. 3—Slow Speed Position

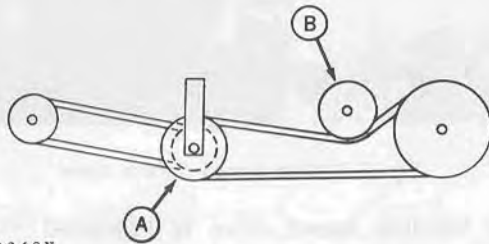

M16648N

- A—Variator
- B—Secondary Belt Idler

Fig. 4—High Speed Position

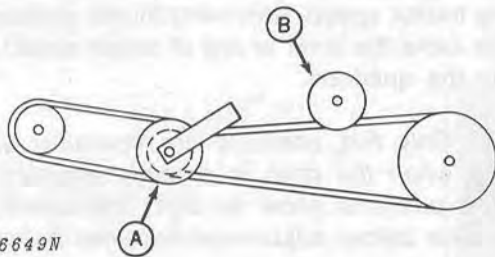

M16649N

- A—Variator
- B—Secondary Belt Idler

Fig. 5—Clutch Position

Figs. 3, 4 and 5 show the different positions of the variable speed drive.

The slow speed position, Fig. 3, will provide for a large primary and small secondary sheave circumference at the variator.

The high speed position, Fig. 4, provides a small primary and large secondary sheave circumference at the variator.

When the clutch pedal is depressed, the variator moves forward and releases the primary belt from the engine drive sheave, Fig. 5.

With this system, travel speeds can be changed while the engine speed remains constant. All transmission gear positions can be used in conjunction with the variable speed control.

NOTE: The engine must be running to allow the variator to change belt positions.

PRELIMINARY DIAGNOSIS OF MALFUNCTIONS

A diagnosis for the clutch and variable speed drive malfunctions appears on page 50-10-4 and 50-10-5. Following are some common considerations to refer to before referring to "Diagnosing Malfunctions".

Probably the most frequent complaint with the variable speed drive is that the tractor will not respond to movement of the variable speed control lever.

First, the engine must be running before the variator can shift belt positions to vary the speed.

Primary belt wear can throw the variable speed linkage out of adjustment. When this happens, there will be no forward travel when the variable speed control lever is in notch 1 on the quadrant (slow speed position).

Adjust the linkage as described on page 50-10-13.

If the tractor is stopped (without depressing the clutch pedal) with the variable speed control lever in the forward position, the belts will jam in the variator if the variable speed control lever is moved back (to the slow speed position) before starting the engine. This will lock the tractor in a declutched position. Move the control lever forward to correct this condition.

To prevent this situation, advise customers against moving the variable speed control lever unless the engine is running.

Check and correct all items listed under "Diagnosing Malfunctions" when variator action and tractor acceleration are sluggish.

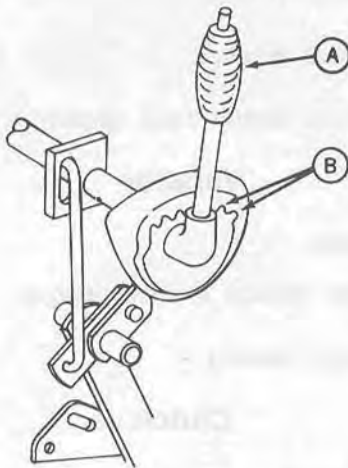

A—Control Lever B—Notches 6 and 7 in Quadrant

Fig. 6-Variable Speed Control Linkage

Second, the variable speed control lever (A), Fig. 6 will not affect tractor speed when the lever is in forward notches 6 or 7 (B) on the quadrant. Positions 6 and 7 are provided to allow for normal belt wear and linkage "tolerances" before adjustment becomes necessary.

However, when the tractor does not respond to movements of the variable speed control lever in other positions on the quadrant, the control linkage needs adjusting. Follow the adjustment procedure, page 50-10-13, carefully.

DIAGNOSING MALFUNCTIONS

Belts

Belts Slip Under Load

- Variator spring not properly adjusted.
- Broken variator spring.
- Weak or broken secondary idler spring.
- Variator linkage not properly adjusted.
- Dirt in variator sheave grooves.
- Glazed or greasy belts.
- V-belts worn or lumpy.
- Dirty or gummy variator sheave hub.
- Worn sheaves.

Primary Belt Jumps Off Variator Sheave

- Primary belt guide improperly located.
- Primary belt too long.
- Oil or grease on belt.
- Worn or nicked variator sheaves.
- Dirt in variator groove.

Secondary Belt Jumps Off Variator Sheave

- Dirt in variator and/or input sheave.
- Worn or nicked variator sheaves.
- Worn, bent or nicked input sheave.
- Worn (center) variator sheave bearing.

Slack Primary Belt

- Variator linkage not properly adjusted.
- Variator spring not properly adjusted.
- Primary belt too long.
- Worn variator sheaves.

Excessive Primary Belt Wear

- Dirty or greasy variator sheave hub.
- Dirt in variator sheave grooves.

Excessive Secondary Belt Wear

- Weak secondary idler spring.
- Secondary belt idler arm pivot binding or misaligned.
- Oil or grease on belt.
- Dirt in sheave grooves.
- Worn, bent or nicked input sheave.

Variator

Noisy Variator

- Worn center variator sheave bearing.
- Worn variator bearing.

Clutch

Clutch Hard to Operate

- Engine not running.
- Variator arm binding in pivot (in pedestal).
- Secondary belt idler arm pivot binding.

Clutch Pedal Creeps Down Under Load

Load and torque sensing feature operating. This is characteristic of drive when encountering loads with variable speed control lever fully forward.

If down-shifting too early, adjust variator spring for greater tension.

- Variator linkage not properly adjusted.

Clutch Will Not Disengage

- Variator not properly adjusted.
- Primary or secondary belt too short.

Clutch Pedal Jumps

- Primary or secondary V-belt worn or lumpy.
- Dirt in sheave grooves.
- Worn variator bearings.
- Worn, bent, or nicked sheaves.
- Loose input sheave on transaxle hub.

Miscellaneous

Tractor Does Not Move (Engine Running)

- Variator binding belts.
Move variable speed control lever forward.
- Parking brake set.
- Variator not properly adjusted.
- Primary belt too long.
- Variator arm binding in pivot (in pedestal).
- Secondary belt idler spring broken.
- Secondary belt idler arm pivot binding.

Excessive Tractor Vibration

- Dirt in sheave grooves.
- Bent or damaged input sheaves.
- Loose input sheave cap screws (transaxle).
- Primary or secondary V-belt worn or lumpy.

Tractor Will Not Move With Variable Speed Control Lever Pulled Back

- Variator not properly adjusted.
- Primary belt too long.
- Dirty or greasy variator sheave hub.

Tractor Will Not Accelerate When Variable Speed Control Lever is Moved Forward

- Variator not properly adjusted.
- Variator spring not adjusted properly.
- Dirty or gummy variator sheave hub.
- Short secondary belt.
- Variator arm binding in pivot (in pedestal).
- Variator center sheave too tight on hub.

Tractor Will Not Attain Specified Travel Speed

- Variator not properly adjusted.
- Clutch shaft binding.
- Dirty or gummy variator sheave hub.
- Variator spring not adjusted properly.
- Weak secondary idler spring.
- Variator arm binding in pivot (in pedestal).

REPAIR

Inspecting V-Belts

The V-belts transmit power by friction and a wedging action against the sheaves. All belts and sheaves wear with use. Normal wear can be recognized as even wear, both on the belt and sides of sheaves.

A slight raveling of the belt does not indicate premature belt failure. Cut off the raveling when the covering begins to peel.

When evidence of extreme or abnormal belt wear is noted, check first for faulty sheaves. A bent, nicked or chipped sheave will cause rapid belt wear. Replace sheaves found in this condition.

Belt wear, tractor vibration, and erratic operation will result when dirt becomes packed and lodged in V-grooves of the sheaves. Check especially the variator sheave. Loosen and clean dirt from all sheaves.

See page 50-10-4 of "Diagnosing Malfunctions" for other possible causes of belt wear.

Cleaning V-Belts

Clean belts by wiping them with a clean cloth. Avoid use of solvents since this will soften the belt materials and cause the clutch to grab. Replace belts found to be oily or greasy.

Do not use belt dressings. Dressings often give only temporary gripping action while softening the belt and causing eventual deterioration, and shortening of the belt life.

Replacing Primary V-Belt

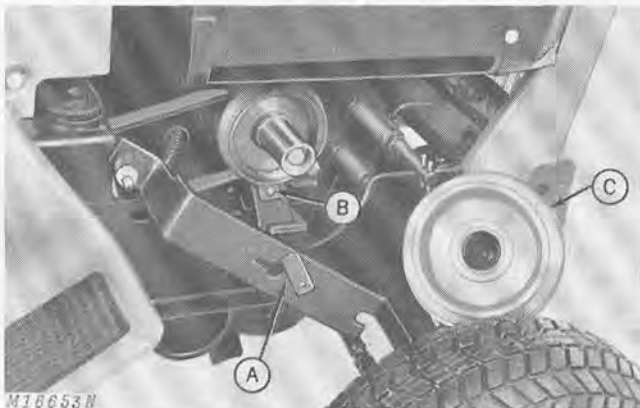

A—PTO Arm B—PTO Brake Shoe C—Clutch Sheave

Fig. 7-Removing PTO Clutch

Remove right-hand side panel. Unclip PTO arm (A) and push it to the rear away from the machine.

Loosen cap screw securing PTO brake shoe (B) enough so PTO clutch sheave (C) can be pulled off the engine crankshaft.

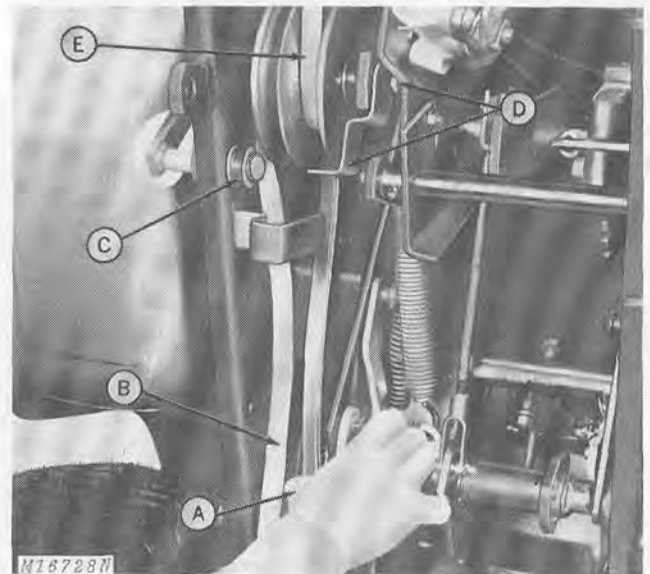

A—Secondary Belt Idler B—Secondary Belt
C—Brake Pedal Shaft D—Primary Belt Guide
E—Primary Belt

Fig. 8-Removing Primary Belt

Move the variable speed control lever forward. Push up on secondary belt idler (A) and remove the secondary belt (B) from variator sheave.

Depress clutch pedal so secondary belt (B) may be pulled past brake pedal shaft (C).

Loosen the primary belt guide (D) at the variator and remove the primary belt (E).

Install new belt in opposite order.

IMPORTANT: After replacing primary belt, re-adjust variator. Refer to "Adjustments" page 50-10-13.

Replacing Secondary V-Belt

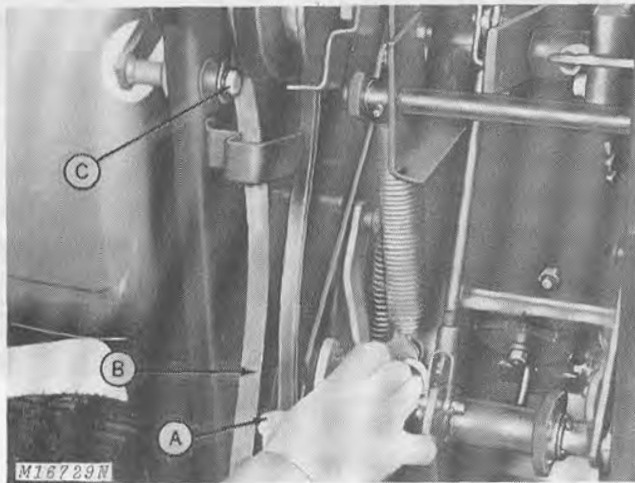

A—Secondary Belt Idler C—Brake Pedal Shaft
B—Secondary Belt

Fig. 9—Replacing Secondary Belt

To replace a worn or broken secondary belt (B), move variable speed control lever forward. Raise the secondary belt idler (A) and slip secondary belt (B) off variator.

Depress clutch pedal to allow secondary belt (B) to be pulled past the brake pedal shaft (C).

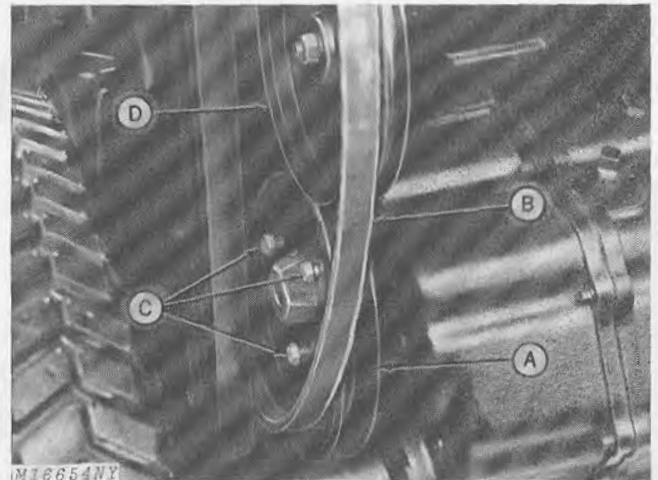

A—Transmission Driven Sheave C—Cap Screws
B—Secondary Belt D—Secondary Belt Idler

Fig. 10—Installing Secondary Belt

Loosen three cap screws on the transmission driven sheave (A) and slide sheave off hub far enough to remove secondary belt (B).

Install new belt on variator sheave.

Raise secondary belt idler (D) and install belt on transmission driven sheave (A). Tighten cap screws (C) onto driven sheave (A).

After belt replacement, check variator and brake adjustments.

Removing Variator

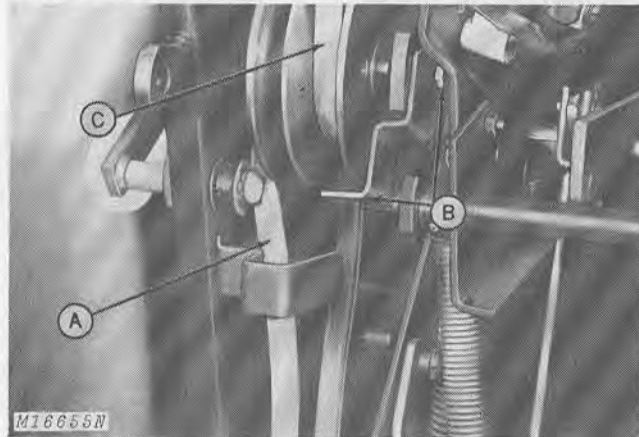

A—Secondary Belt B—Primary Belt Guide
C—Primary Belt

Fig. 11-Removing Variator

Remove secondary belt (A) from the variator sheave. See page 50-10-7.

Loosen 5/16-inch (7.938 mm) cap screw securing primary belt guide (B) to variator arm. Pivot guide away to allow room for primary belt (C) to be removed.

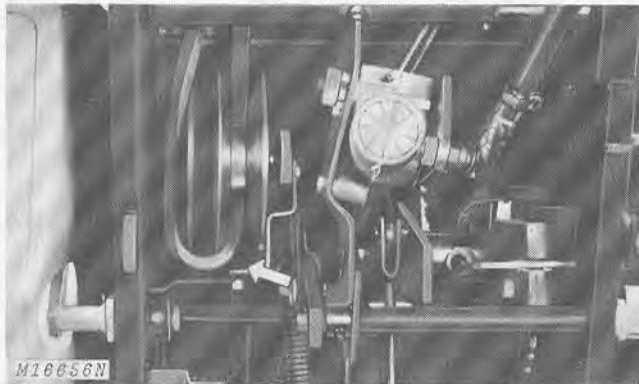

Fig. 12-Removing Variator

Depress clutch pedal to pivot variator forward. Remove primary belt from variator sheave.

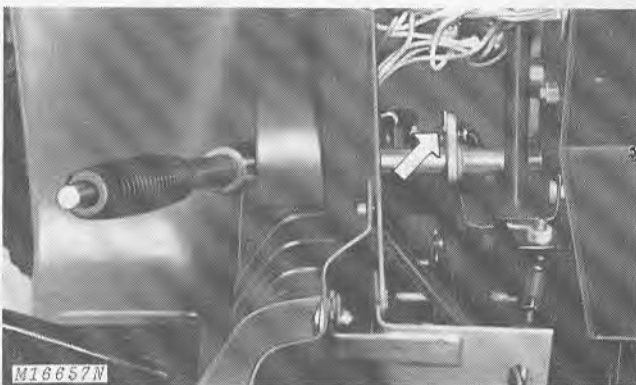

Fig. 13-Disconnecting Speed Control Link

Remove battery and battery base to provide access. Disconnect speed control shaft link from speed control shaft.

Litho in U.S.A.

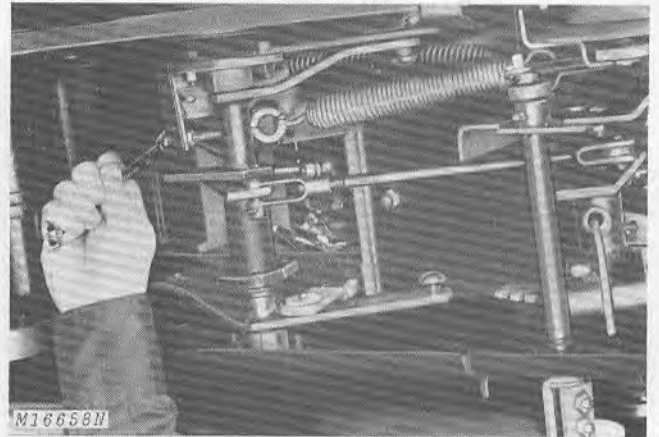

Fig. 14-Removing Variator Spring

Move the variable speed control lever forward.

Disconnect variator spring by removing nut from eyebolt.

⚠ CAUTION: Variator spring is under slight tension.

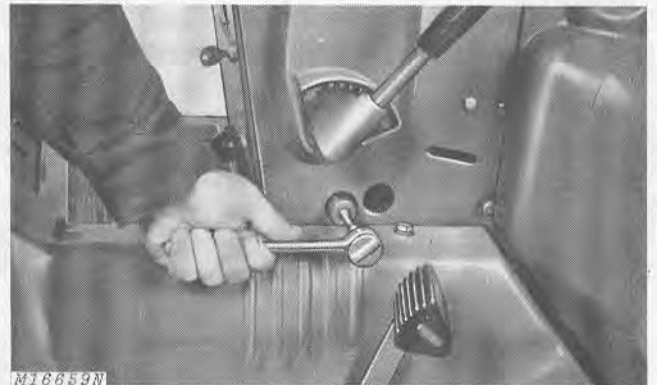

Fig. 15-Removing Pivot Shoulder Bolt

Remove plug from pedestal and remove variator pivot shoulder bolt.

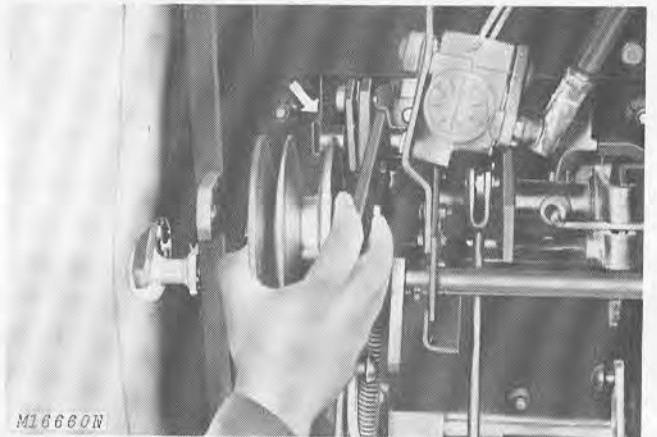

Fig. 16-Removing Variator

Guide variator assembly out through bottom of tractor.

Disassembling Variator



A—Half Sheave B—Vise C—Center Sheave

Fig. 17-Removing Variator Sheaves

Place variator half sheave (A), Fig. 17, in a vise (B), with soft jaws. Insert ends of two large punches in holes of sheave. Place a bar between punches. Then turn counterclockwise to remove half sheave. Lift center sheave (C) from variator hub.

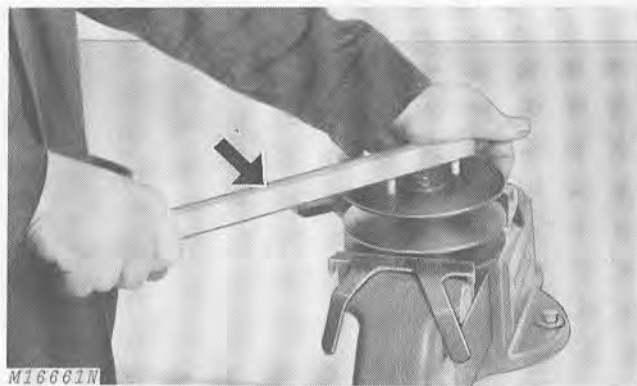
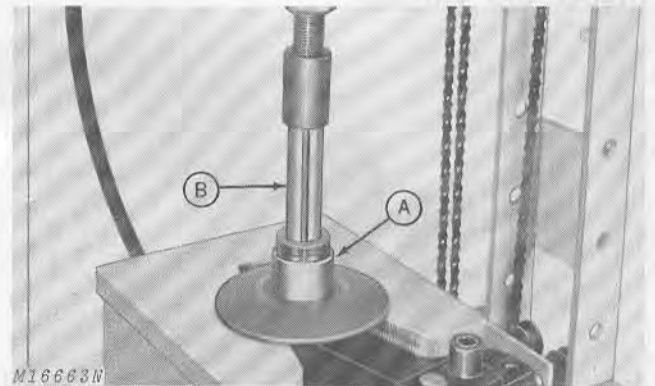

Fig. 18-Removing Variator Sheaves with Special Tool

Using the same procedure as described above, a special tool, Fig. 18, can be used. This tool is not available from a supplier, but can be made by drilling a bar of steel and inserting 3/8-inch (9.525 mm) round stock, 2-3/4 inches (69.850 mm) apart at the centers and 1-inch (25.400 mm) long. After tool has been tried and checked, weld round stock in place.



A—Hub Assembly

B—Press

Fig. 19-Pressing Hub Bearing

Place variator bearing and hub assembly (A) under press (B) with sheave down Fig. 19. Press bearing from hub. Be sure to press against outer race only.

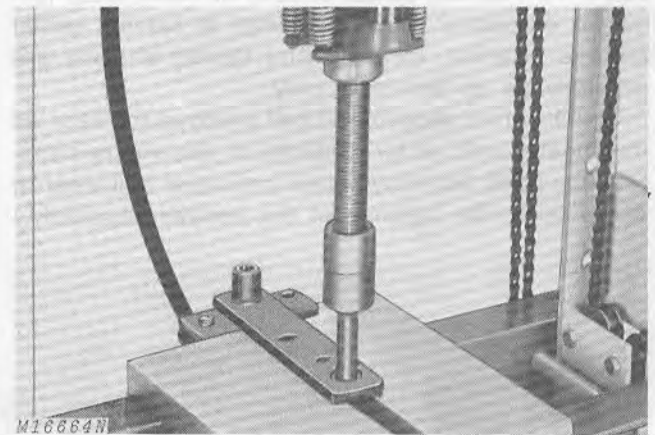
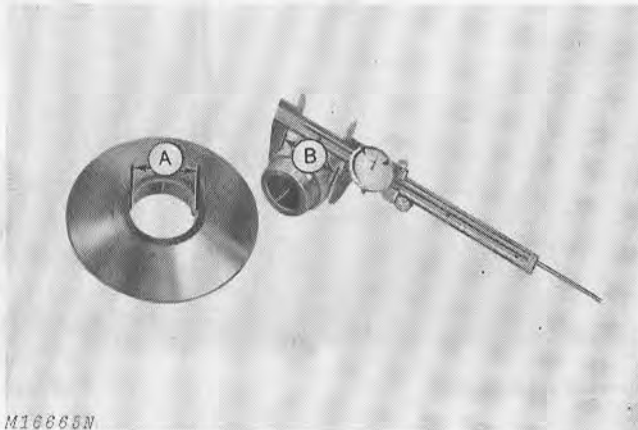

Fig. 20-Press Variator Shaft

Place hub in a vise with soft jaws and remove other half sheave as described at the left, using punches or the special tool. Press bearing out of variator arm as shown in Fig. 20.

Inspecting Variator



A—I.D. of Center Sheave Bearing B—O.D. of Variator Hub

Fig. 21-Measuring Center Sheave and Hub

After cleaning parts thoroughly, measure I.D. of center sheave bearing (A) and O.D. of variator hub (B), Fig. 21. Refer to wear tolerances, page 50-10-14. Replace center sheave or hub if wear limits are exceeded. Do not attempt to service center sheave bearing. Bearing and center sheave are available as an assembly only.

Check center sheave and half sheaves for wear on the sheave faces or for evidence of damage or nicks. Replace parts that may cause excessive belt wear or would upset the balance of the variator assembly.

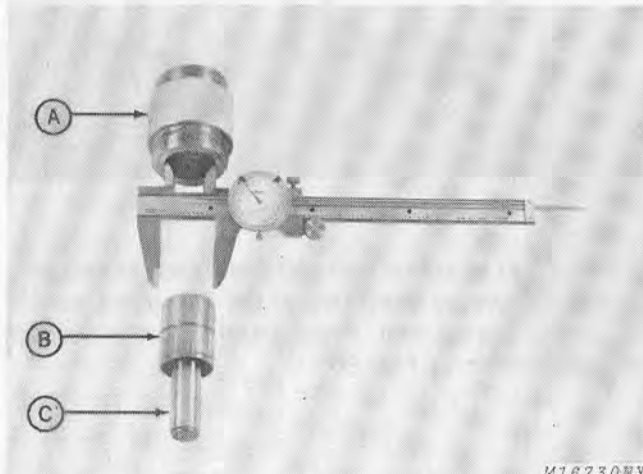

A—Bearing B—Hub C—Shaft

Fig. 22-Measuring Hub and Bearing

Measure press fit between bearing (A) and hub (B), Fig. 22. Refer to wear tolerances, page 50-10-4. Check press fit of bearing shaft (C) in variator arm. Replace parts necessary to obtain proper fit.

IMPORTANT: The center sheave bearing is lubricated with a special grease at the factory that will last for the lifetime of the sheave. Do not attempt to lubricate this bearing.

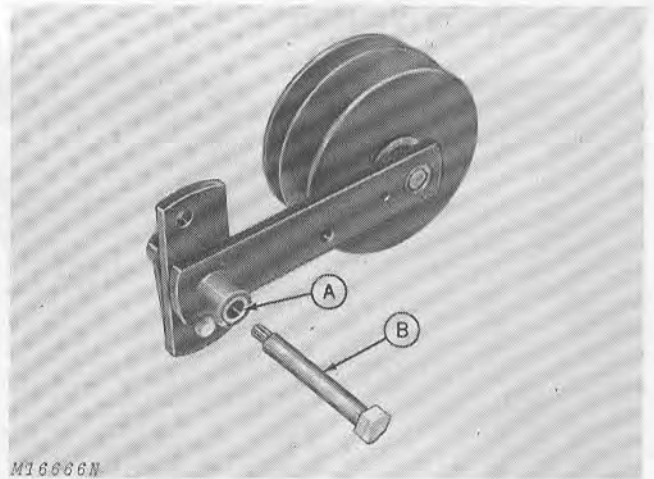

A—Bushing

B—Shoulder Bolt

Fig. 23-Inspecting Shoulder Bolt and Bushing

Inspect brass bushings (A) and shoulder bolt (B) for wear or damage, Fig. 23. The variator arm must pivot freely.

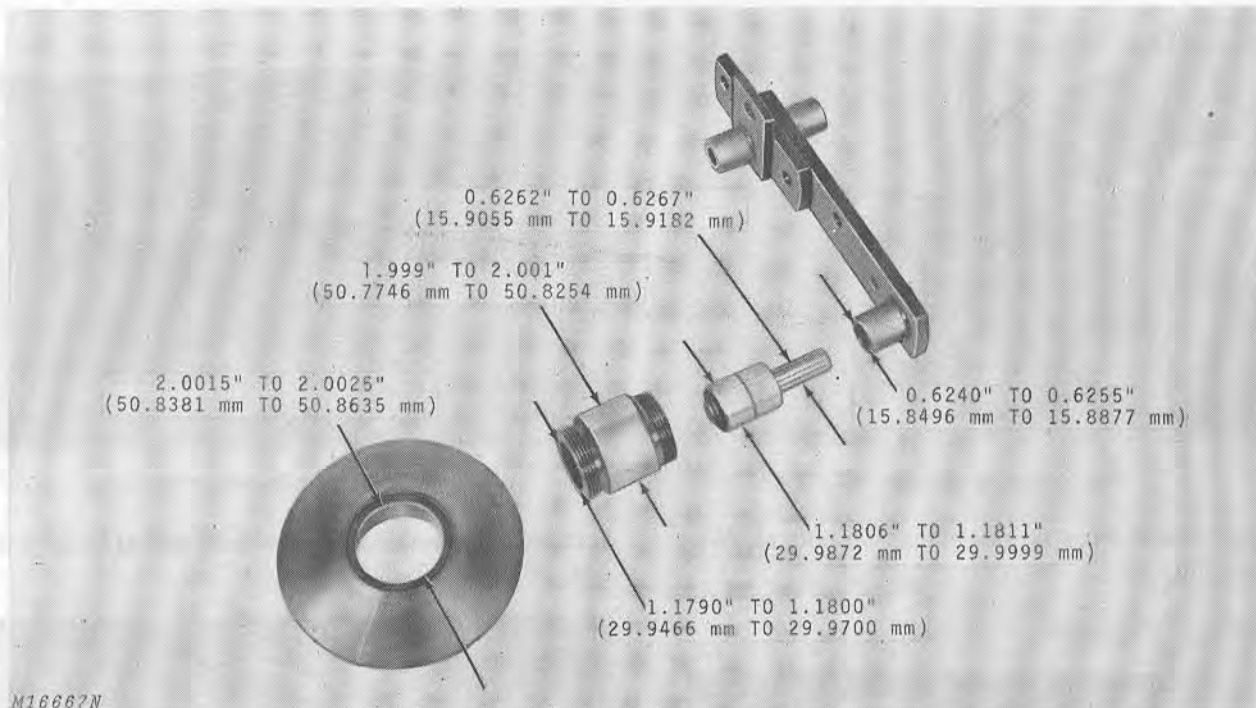

Fig. 24-Variator Component Dimensions

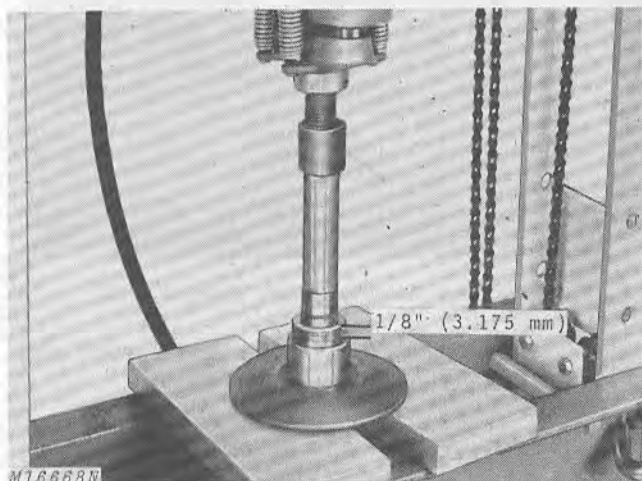

Fig. 25-Press Bearing on Hub

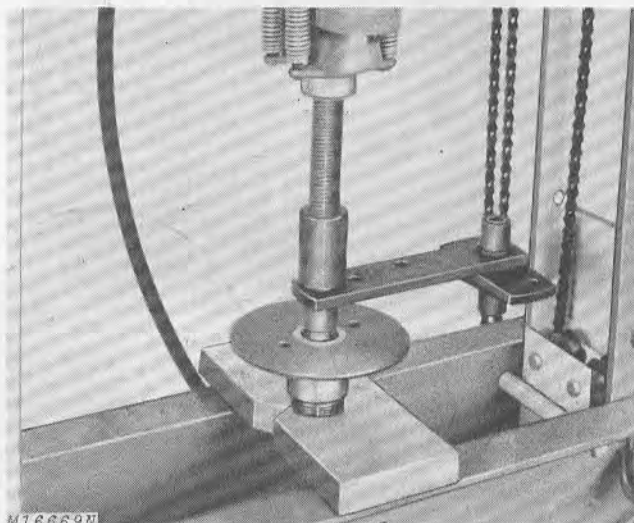

Fig. 26-Press Arm on Shaft

Assembling Variator

Thread one sheave onto hub. Coat bearing case with a light film of oil. Place hub with sheave on press bed. Press bearing into hub shaft first until bearing end is 1/8 inch (3.175 mm) below hub face, Fig. 25.

IMPORTANT: Press on outer race of bearing only.

Wipe a light film of oil on bearing shaft. Place variator arm on bearing shaft with weld down. Press variator arm on bearing shaft until end of bearing shaft is flush with outside of variator arm, Fig. 26.

Clamp assembly in vise having soft jaws. Place center sheave on hub and thread half sheave on hub. Using two large punches and bar, or special tool, tighten sheaves firmly by turning sheave in clockwise direction.

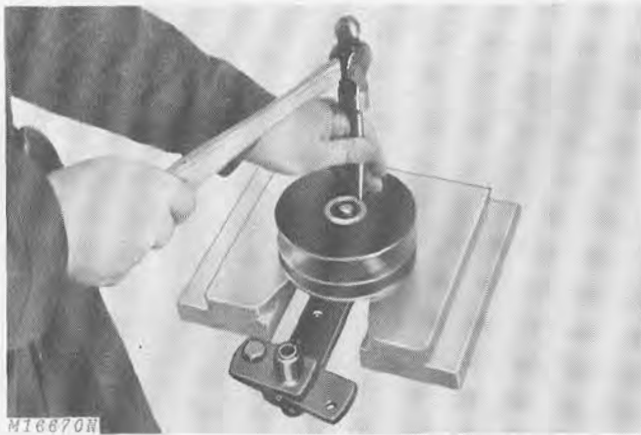

Fig. 27-Spiking Threads

Spike threads three or four places on both sides of variator, Fig. 27.

Installing Variator

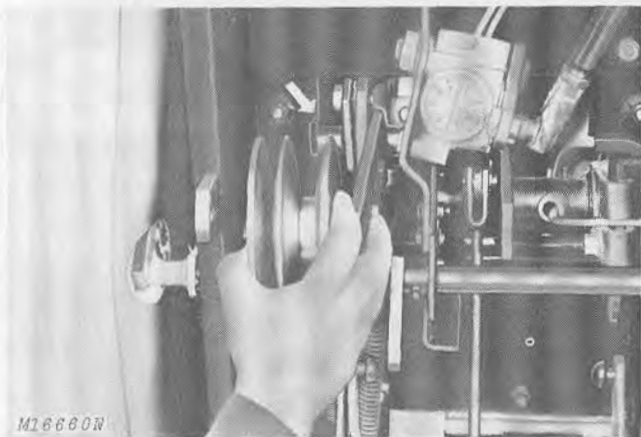

Fig. 28-Installing Variator

Install variator assembly from under tractor. Guide pivot through notch in tractor frame, Fig. 28.

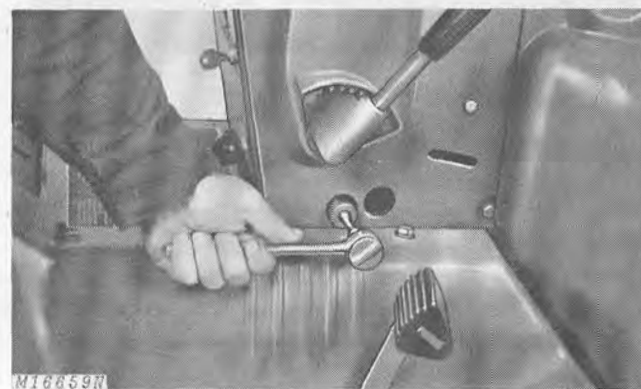

Fig. 29-Installing Shoulder Bolt

Install shoulder bolt and tighten securely, Fig. 29.

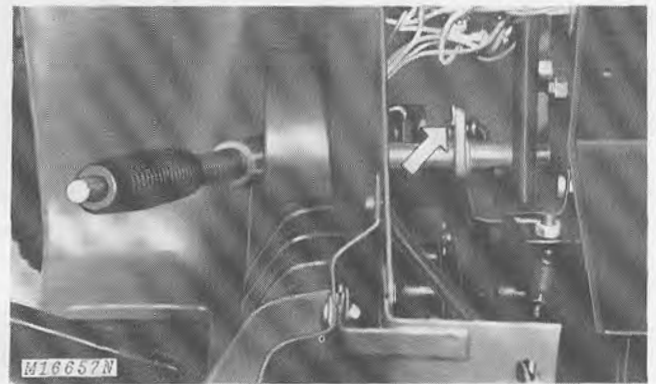

Fig. 30-Connecting Speed Control Link

Connect speed control link with spring locking pin, Fig. 30.

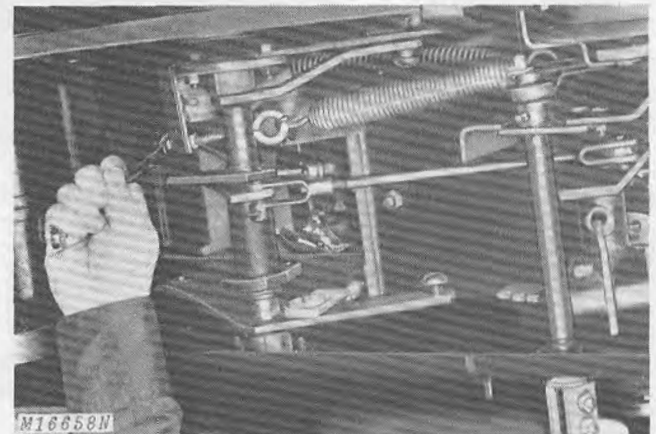

Fig. 31-Installing Variator Spring

Attach variator spring to variator and eyebolt and tighten eyebolt for desired tension, Fig. 31.

Reinstall battery base and battery.

Reinstall belts on variator.

After installation is completed, make final adjustments to variator.

ADJUSTMENTS

Linkage Adjustment



A—Variable Speed Control Lever
B—Socket Wrench
C—Ignition Key
D—Cap Screw

Fig. 32-Adjusting Variator

1. To adjust the variator linkage, place the variable speed control lever (A) in notch 5 on the quadrant, which is the third notch from the front of the tractor.
2. Pry button plug from adjusting hole in right side of the tractor pedestal and loosen cap screw (D) one to two turns with a 3/4-inch (19.050 mm) socket wrench (B).
3. Disconnect spark plug cable and ground. Turn ignition key (C) to crank engine several revolutions with starter until the clutch pedal raises as high as it will go.
4. Take up slack in linkage by pushing down on cap screw (D). Tighten cap screw (D) and replace button plug in adjusting hole.

NOTE: If, after adjusting variator linkage, tractor will not move when the variable speed control lever is in first notch on the quadrant (slow speed position) and the clutch pedal is released, install a new primary belt.

Spring Adjustment

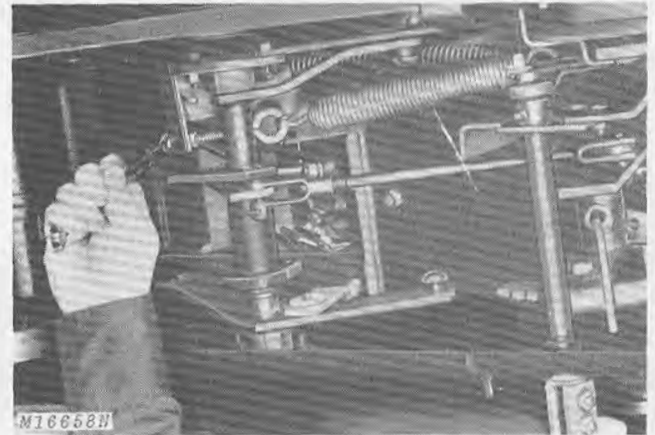

Fig. 33-Adjusting Variator Spring

To obtain desired torque and load sensing characteristics, adjust the variator spring as follows:

For greater load sensitivity (variator increases torque earlier under load) loosen the spring tension by lengthening the eyebolt. For less load sensitivity, tighten the spring tension by shortening the eyebolt.

Belt Guide Adjustment

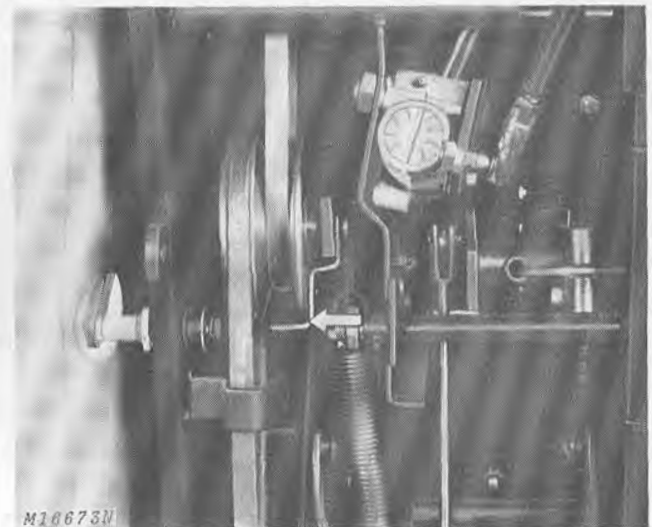

Fig. 34-Adjusting Belt Guide

If the primary belt jumps the variator sheave when the clutch pedal is depressed, the distance between the variator and primary belt guide should be checked. Distance between guide and sheave should not exceed 1/8 inch (3.175 mm).

SPECIFICATIONS

Component	Dimension
Center Sheave I.D. with Bearing	2.0015 to 2.0025 in. (50.8381 mm to 50.8635 mm)
Hub O.D.	1.999 to 2.001 in. (50.7746 mm to 50.8254 mm)
Hub I.D.	1.1790 to 1.1800 in. (29.9466 mm to 29.9700 mm)
Bearing O.D.	1.1806 to 1.1811 in. (29.9872 mm to 29.9999 mm)
Bearing Shaft O.D.	0.6262 to 0.6267 in. (15.9055 mm to 15.9182 mm)
Bearing Support I.D.	0.6240 to 0.6255 in. (15.8496 mm to 15.8877 mm)
Primary Belt Guide (Distance Between Variator and Guide)	1/16 to 1/8 in. (1.588 mm to 3.175 mm)



Group 15 BRAKES

PRINCIPLE OF OPERATION

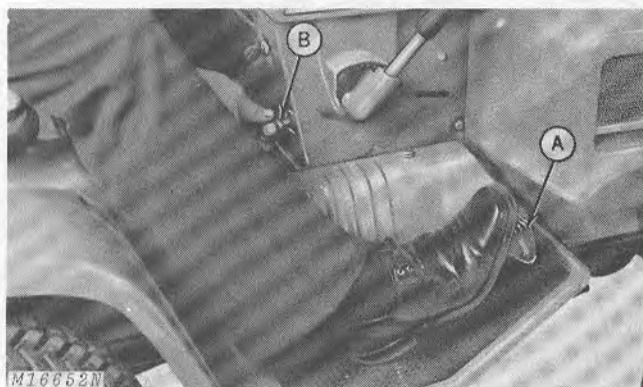

A—Brake Pedal

B—Parking Brake Knob

Fig. 1-Setting Parking Brake

The clutch and brake pedals operate independently of each other.

Depressing the clutch pedal moves the variator forward to disengage the drive. The brake band tightens around the brake pulley as the brake pedal (A) is depressed. To set the parking brake, depress brake pedal (A) and move the parking brake knob (B) downward in its slot as shown in Fig. 1.

DIAGNOSING MALFUNCTIONS

No Brakes or Ineffective Brakes

- Brake linkage not properly adjusted.
- Broken band.
- Worn lining.
- Oil on lining.

DESCRIPTION

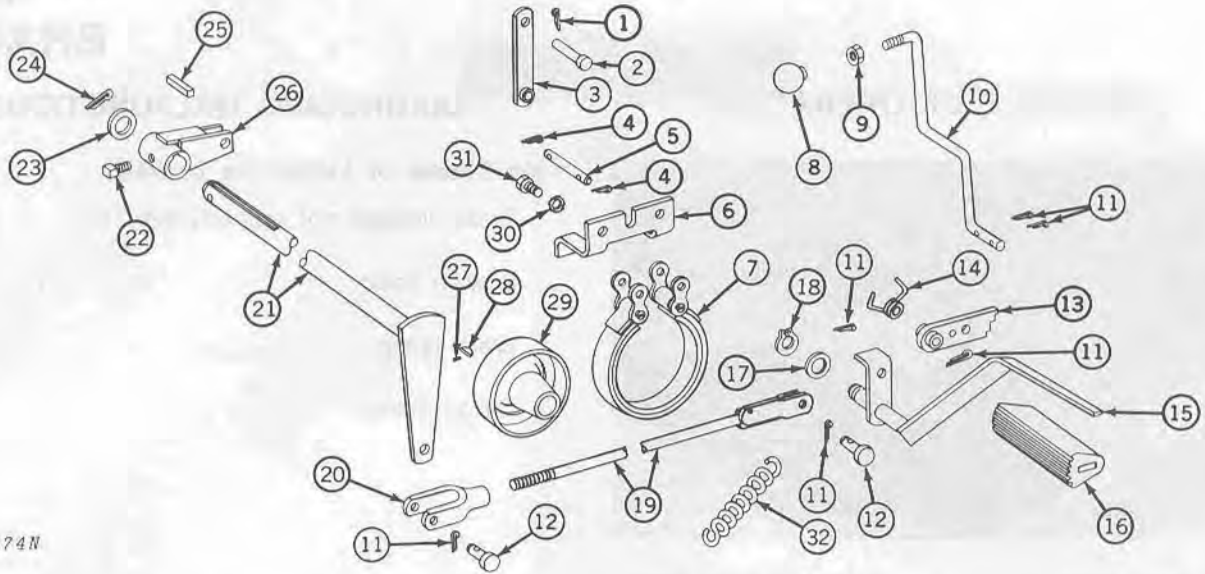

M20974N

- | | | | | |
|---------------|----------------|----------------|----------------|-------------------------------|
| 1—Cotter Pin | 8—Knob | 15—Pedal | 21—Shaft | 27—Set Screw |
| 2—Drilled Pin | 9—Nut | 16—Pad | 22—Set Screw | 28—Woodruff Key |
| 3—Link | 10—Lever | 17—Flat Washer | 23—Flat Washer | 29—Pulley |
| 4—Cotter Pin | 11—Cotter Pin | 18—Snap Ring | 24—Cotter Pin | 30—Internal Tooth Lock Washer |
| 5—Drilled Pin | 12—Drilled Pin | 19—Rod | 25—Square Key | 31—Cap Screw |
| 6—Bracket | 13—Ratchet | 20—Yoke | 26—Arm | 32—Return Spring |
| 7—Band | 14—Spring | | | |

Fig. 2-Exploded View of Brake Components Serial Number () -55000)

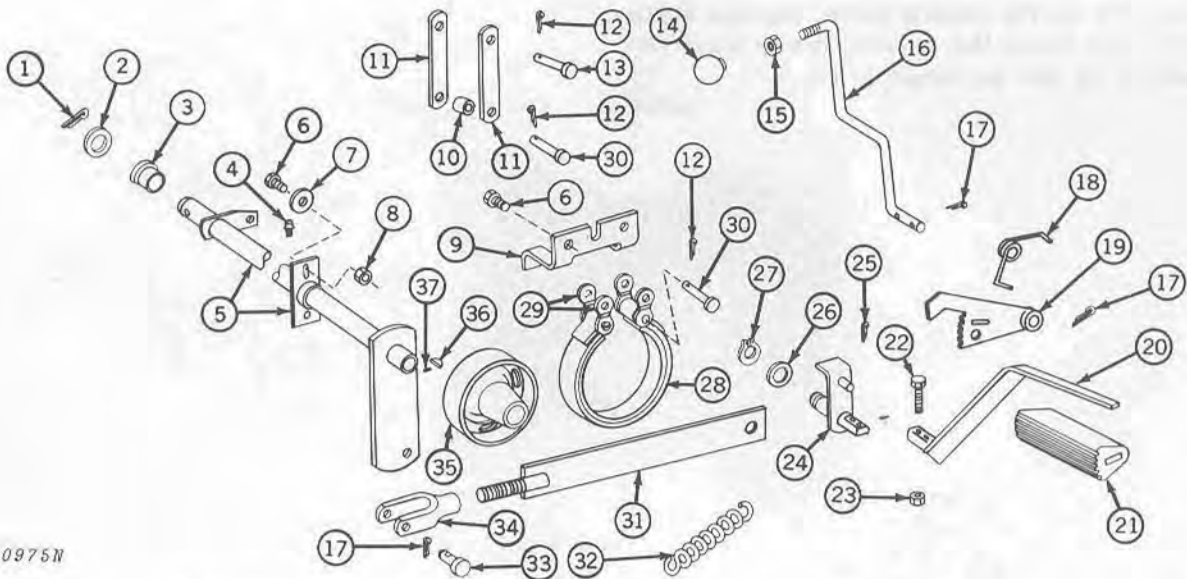

M20975N

- | | | | | |
|------------------|----------------|--------------------|--------------------|------------------|
| 1—Cotter Pin | 9—Bracket | 17—Cotter Pin | 24—Brake Pedal Pad | 31—Brake Rod |
| 2—Flat Washer | 10—Spacer | 18—Springs | 25—Cotter Pin | 32—Return Spring |
| 3—Bearing | 11—Link | 19—Ratchet | 26—Flat Washer | 33—Drilled Pin |
| 4—Grease Fitting | 12—Cotter Pin | 20—Brake Pedal | 27—Snap Ring | 34—Yoke |
| 5—Brake Shaft | 13—Drilled Pin | 21—Brake Pedal Pad | 28—Brake Band | 35—Brake Pulley |
| 6—Cap Screw | 14—Knob | 22—Cap Screw | 29—Link | 36—Woodruff Key |
| 7—Flat Washer | 15—Nut | 23—Nut | 30—Drilled Pin | 37—Set Screw |
| 8—Nut | 16—Brake Rod | | | |

Fig. 3-Exploded View of Brake Components Serial Number (55001-)

REPAIR

Replacing Brake Band

A brake band with bonded lining is used on all 200 Series Tractors. Whenever brake band service is required because of a worn or damaged lining, follow this procedure:

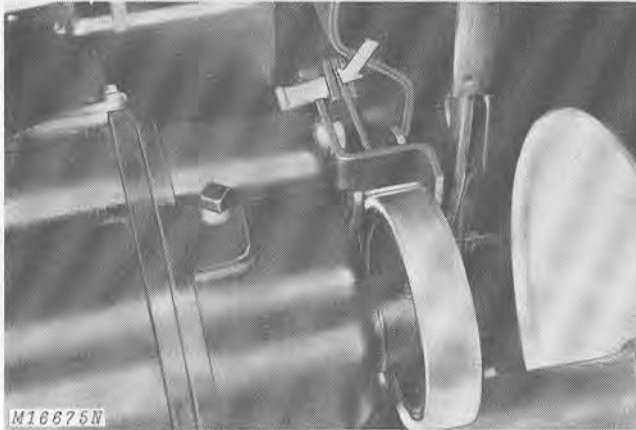

Fig. 4-Disconnecting Brake Arm

Remove cotter pin and drilled pin from brake arm, Fig. 4.



A—Access Holes
B—Brake Band
C—Brake Pulley

Fig. 5-Removing Brake Band

There are two access holes (A) in the left-hand frame through which a socket and extension can be inserted to remove the brake band retaining cap screws.

Remove the left-hand rear wheel. Remove the two cap screws and slip brake band (B) off bottom of brake pulley (C), Fig. 5. Lift band assembly upward and to the right to remove.

Litho in U.S.A.

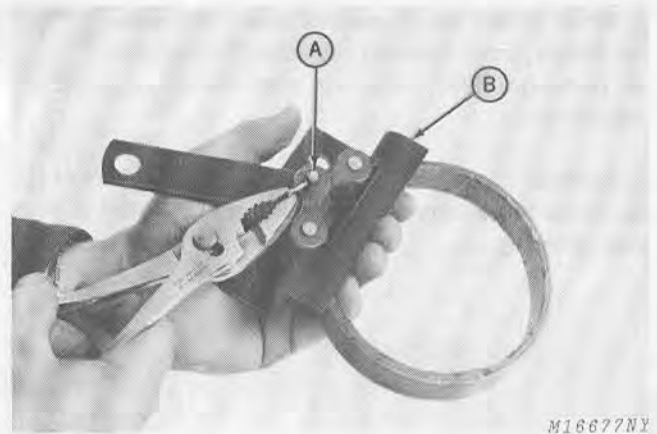

A—Brake Pin
B—Bracket

Fig. 6-Removing Brake Pin

Remove brake pin (A), Fig. 6, and separate brake assembly from bracket (B).

Reverse disassembly procedure to install new brake band.

After installing brake band assembly on tractor, see page 50-15-4, adjust brake linkage.

Replacing Brake Pulley

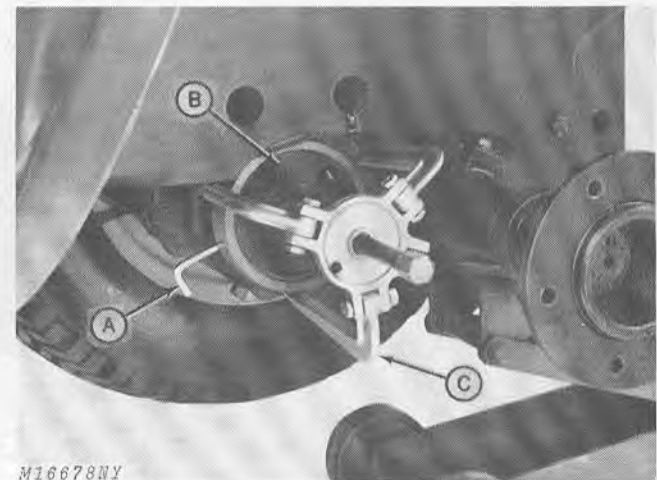

A—Hex. Socket Wrench
B—Brake Pulley
C—Puller

Fig. 7-Removing Brake Pulley

Loosen pulley retaining set screw with hex. socket wrench (A). Remove brake pulley (B) using a puller (C), Fig. 7.

When replacing pulley, tap pulley onto shaft with a soft mallet and install set screw. Use a thread lock compound to secure set screw.

ADJUSTMENT

When brake pedal pushes down to fender deck or no longer gives braking pressure, adjust brake. Lack of parking brake pressure also indicates need for adjustment.

Remove pin (A) and turn clevis (B) on brake rod (C) as far as necessary to put brake in first notch of park lock (D), Fig. 8.

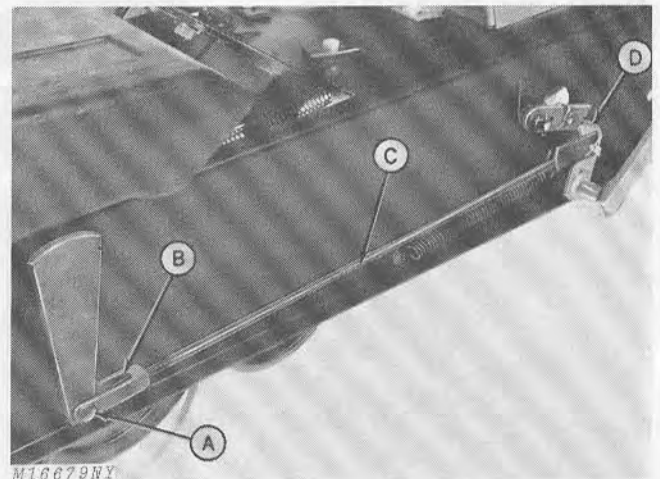

- A—Pin
- B—Clevis
- C—Brake Rod
- D—Park Lock

Fig. 8-Adjusting Brake (Rear Wheel and Fender-Deck Removed to Illustrate Parts)

Group 20 4-SPEED TRANSAXLE

PRINCIPLE OF OPERATION

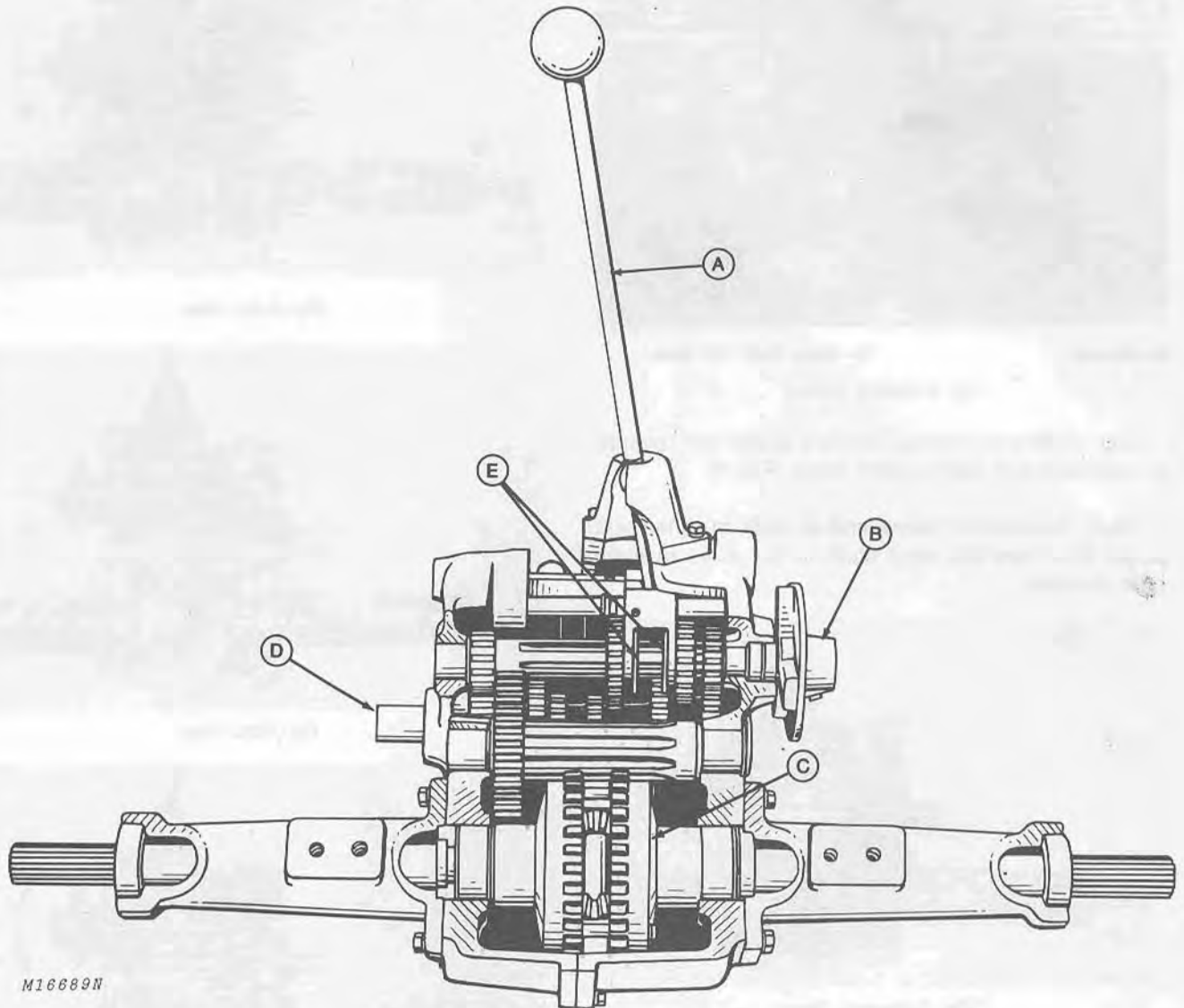

M16689N

A—Shift Lever
B—Input Shaft
C—Differential

D—Brake Shaft
E—Shifter Forks

Fig. 1-Tractor Transaxle - 4 Forward Speeds - 1 Reverse

The transaxle, Fig. 1, is a complete unit consisting of a transmission and differential axle. Gear shifting is accomplished by a direct-mounted shift lever connected to the four forward gears and one reverse.

There are two distinct shifter fork and gear assemblies: one for reverse, first and second; the other for third and fourth.

The transaxle has automotive-type alloy gears turning on anti-friction bearings and is oil-bath lubricated. Needle bearings are used throughout except for the input shaft bearing and axle housing bearings which are ball bearings.

GEAR SHIFT PATTERN

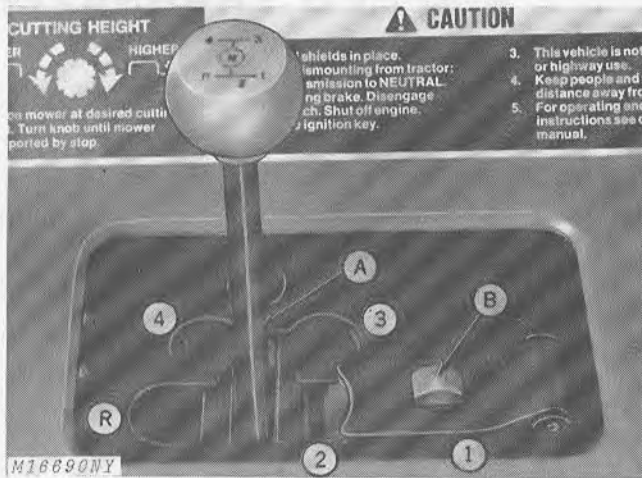

A—Neutral B—Stop Over 1st Gear

Fig. 2-Shifting Pattern

Gear shifting for all four forward gears and reverse is accomplished with a shift lever, Fig. 2.

Study illustrations below and at right to determine power flow from the input shaft to the axles in each gear position.

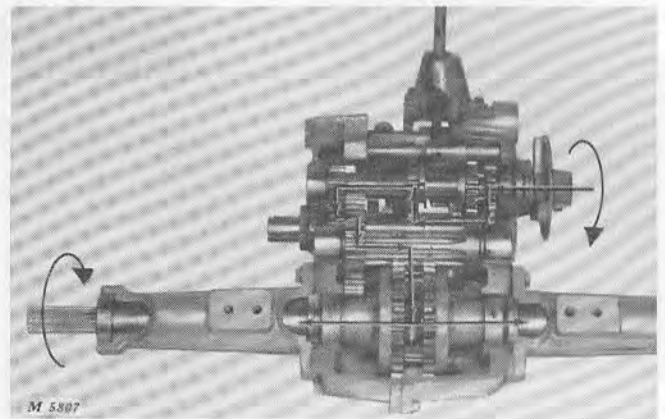

Fig. 5-2nd Gear

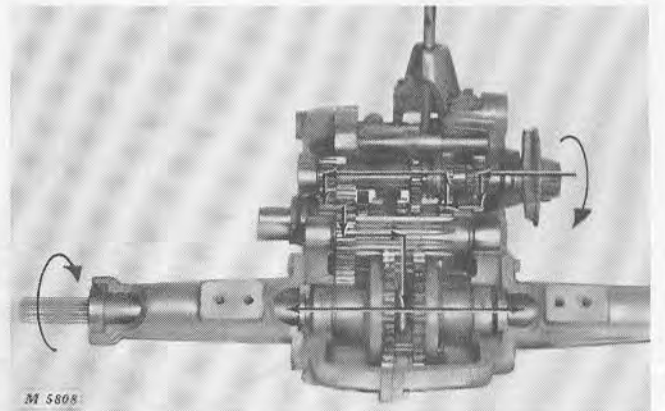

Fig. 6-3rd Gear

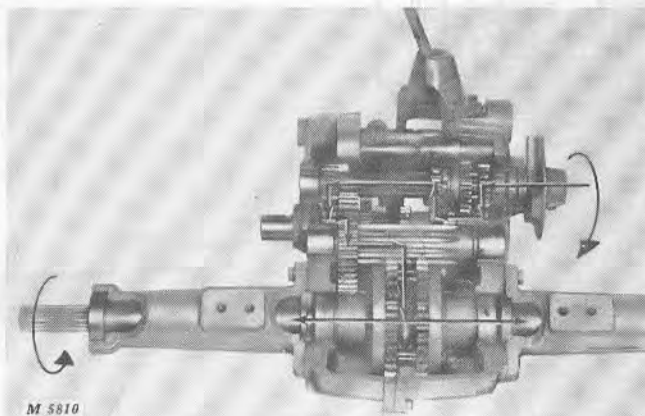

Fig. 3-Reverse Gear

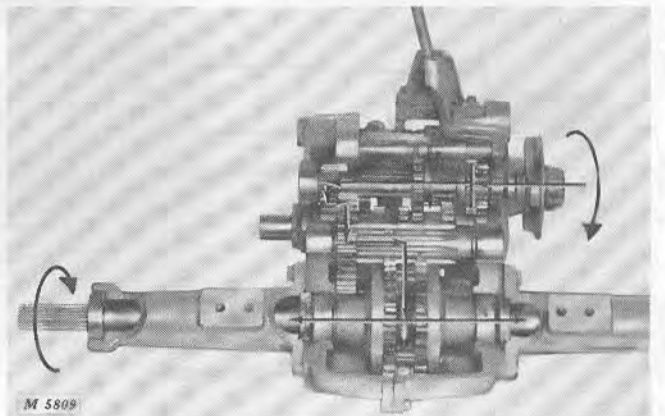

Fig. 7-4th Gear

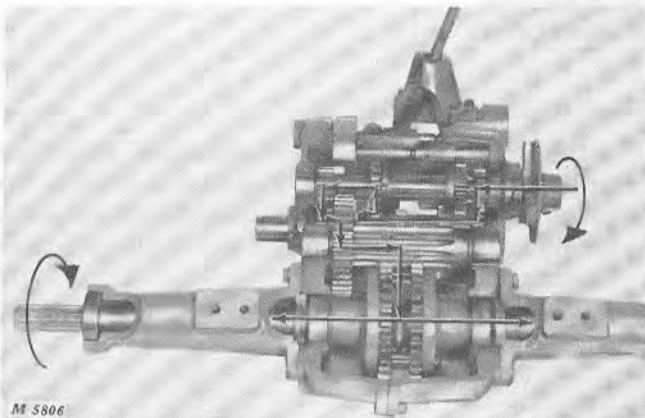

Fig. 4-1st Gear

DIAGNOSING MALFUNCTIONS

Gears Clash When Shifting

- Variable speed control not properly adjusted.
- Shifting gears while tractor is in motion.
- Clutch pedal not fully depressed.
- Linkage not properly assembled.

Hard Shifting.

- Variable speed control not properly adjusted.
- Shifting gears while tractor is in motion.
- Clutch pedal not fully depressed.
- Loose shifter housing bolts.
- Shift quadrant not properly adjusted.
- Shifter forks, rod(s), or other transmission gear selection components damaged.
- Worn shifter lever assembly.

Jumps Out of Gear.

- Quadrant not properly adjusted.
- Gear(s) damaged from shifting while tractor is in motion.
- Worn spline on input shaft.
- Worn shifter gear spline.
- Shifter forks, rod(s), or other transmission gear selection components damaged.

Locked in Gear.

- Variable speed control not properly adjusted.
- Clutch pedal not fully depressed.

Noisy Forward Speeds.

- Low lubricant level.
- Differential bevel gears worn or damaged.
- Gears worn or damaged in transmission section of transaxle.
- Worn or damaged bearing.

Noisy in Reverse.

- Low lubricant level.
- Reverse idle gear and/or shaft worn or damaged.
- Differential bevel pinion gear(s) worn or damaged.

Lubricant Leaks.

- Excessive lubricant.
- Loose case screws.
- Loose shifter housing bolts.
- Worn or damaged shifter housing seal.
- Worn or damaged shaft seal.
- Defective O-ring between case and axle housing.
- Defective case gasket.

DISASSEMBLY

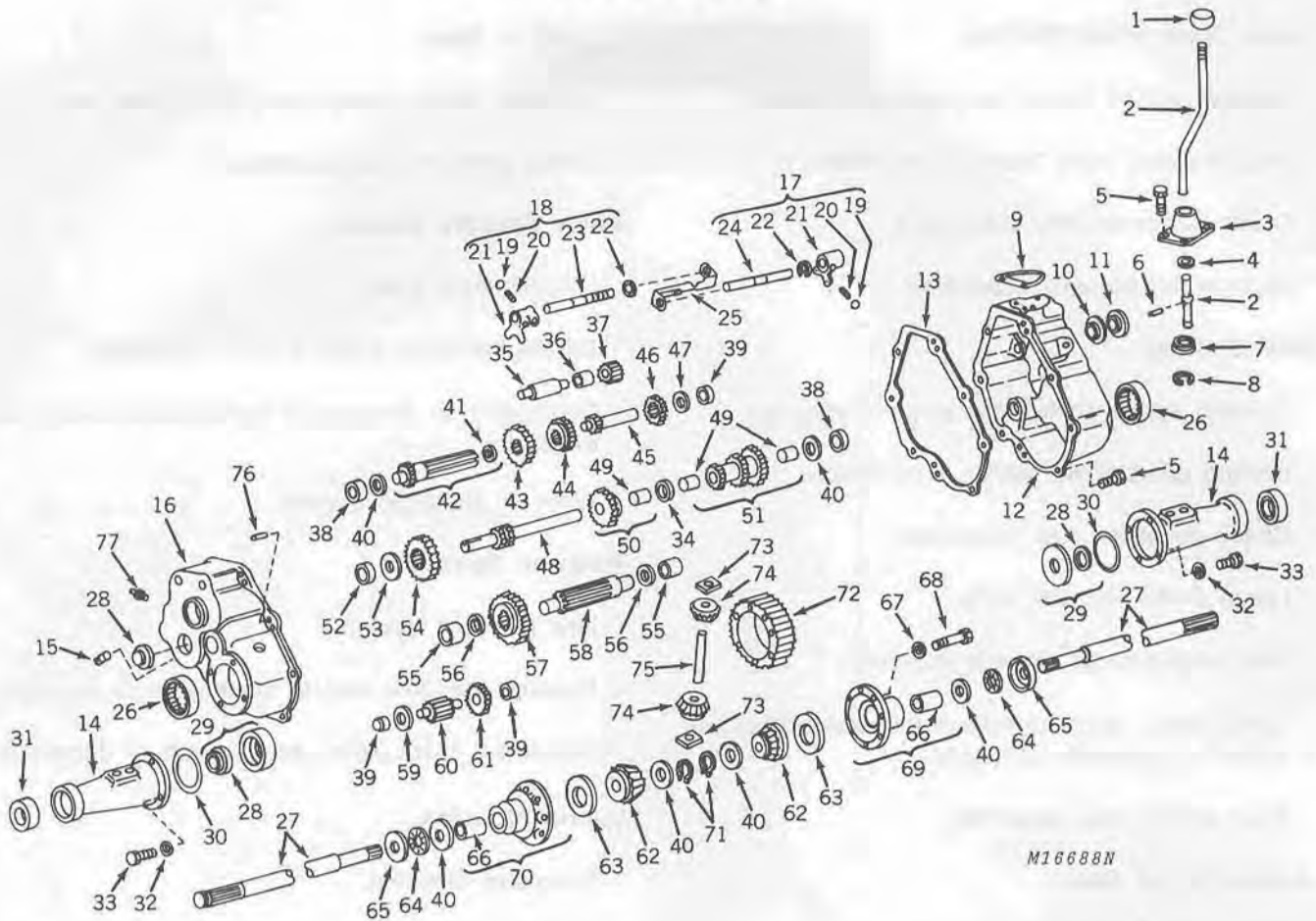

M16688N

- | | | |
|-------------------------------------|--|----------------------------|
| 1—Knob | 27—Axle (2 used) | 53—Thrust Washer |
| 2—Lever Shift | 28—Oil Seal (3 used) | 54—Idler Gear |
| 3—Shift Lever Housing | 29—Seal and Retainer Assembly (2 used) | 55—Needle Bearing (2 used) |
| 4—Quadrant Ring | 30—O-Ring (2 used) | 56—Thrust Washer (2 used) |
| 5—Cap Screw (11 used) | 31—Ball Bearing (2 used) | 57—Output Gear |
| 6—Drive Pin | 32—Lock Washer (8 used) | 58—Output Pinion |
| 7—Shift Lever Keeper | 33—Cap Screw (8 used) | 59—Washer |
| 8—Snap Ring | 34—Spacer | 60—Pinion Shaft |
| 9—Gasket | 35—Reverse Idler Shaft | 61—Spur Gear (22 teeth) |
| 10—Ball Bearing | 36—Spacer | 62—Bevel Gear (2 used) |
| 11—Oil Seal | 37—Reverse Idler | 63—Washer (2 used) |
| 12—Case | 38—Needle Bearing (2 used) | 64—Thrust Bearing (2 used) |
| 13—Gasket | 39—Needle Bearing (3 used) | 65—Thrust Race (2 used) |
| 14—Axle Housing (2 used) | 40—Thrust Washer (6 used) | 66—Bushing (2 used) |
| 15—Magnetic Drain Plug | 41—Bearing | 67—Lock Washer (8 used) |
| 16—Cover | 42—Shaft and Bearing Assembly | 68—Cap Screw (8 used) |
| 17—Rod Assembly | 43—Gear | 69—Carrier Assembly |
| 18—Rod Assembly | 44—Gear | 70—Carrier Assembly |
| 19—Steel Ball (2 used) | 45—Input Shaft | 71—Snap Ring (2 used) |
| 20—Spring (2 used) | 46—Input Shaft Gear | 72—Ring Gear |
| 21—Shifter Fork (2 used) | 47—Thrust Washer | 73—Drive Block (2 used) |
| 22—Snap Ring (2 used) | 48—Shaft and Gear | 74—Bevel Pinion (2 used) |
| 23—Shifter Rod (1st, 2nd & reverse) | 49—Bushing (3 used) | 75—Drive Pin |
| 24—Shifter Rod (3rd & 4th) | 50—Cluster Gear Assembly | 76—Dowel Pin (2 used) |
| 25—Shifter Stop | 51—Cluster Gear Assembly | 77—Pipe Plug (2 used) |
| 26—Needle Bearing (2 used) | 52—Needle Bearing | |

Fig. 8-4-Speed Transaxle Assembly

Removing Transaxle

Remove fender-deck.

Remove fuel tank.

Remove secondary belt, page 50-10-7.

Block up tractor frame and remove rear wheels.

Disconnect brake arm, page 50-15-3.

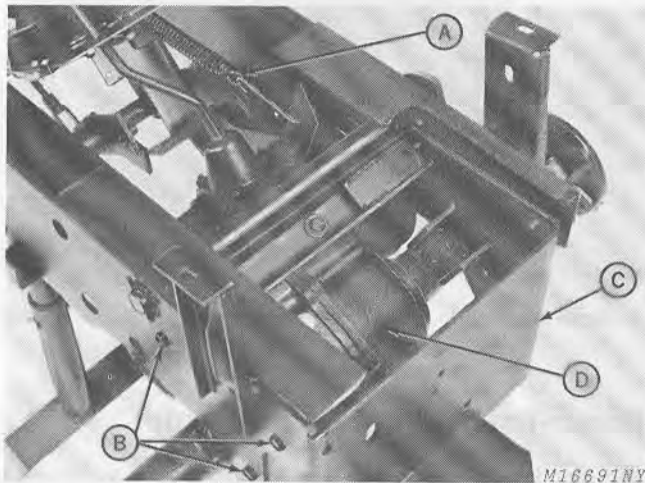

A—Idler Spring
B—Cap Screws
C—Hitch Plate
D—Transaxle

Fig. 9-Removing Transaxle

Remove idler spring (A).

CAUTION: Tension on idler spring is severe. Place variator control in "FAST" position to reduce tension then remove spring.

Place jack under transaxle and remove six cap screws (B) holding hitch plate (C) to tractor frame. Roll transaxle (D) and hitch plate (C) to the rear.

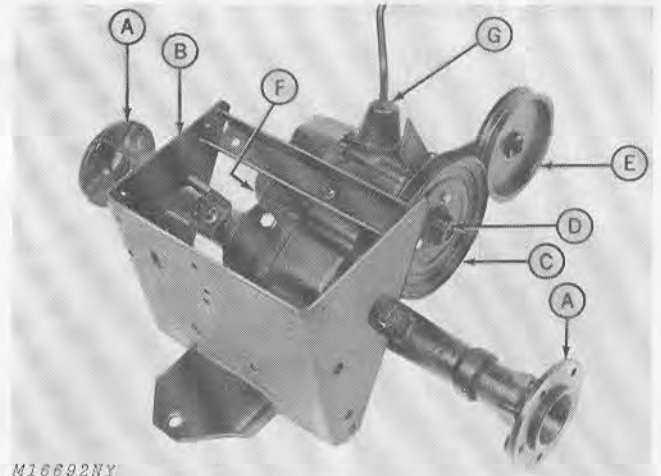

M16692NY

A—Wheel Hubs
B—Hitch Plate
C—Driven Sheave
D—Input Hub
E—Secondary Belt Idler
F—Brake Band Assembly
G—Shift Lever

Fig. 10-Preparing Transaxle for Disassembly

To facilitate transaxle disassembly, remove the components illustrated above, Fig. 10.

When removing the shift lever assembly, place lever in neutral before removing retaining screws.

When removing wheel hubs, use a wheel or gear puller to prevent damage.

Opening Transaxle

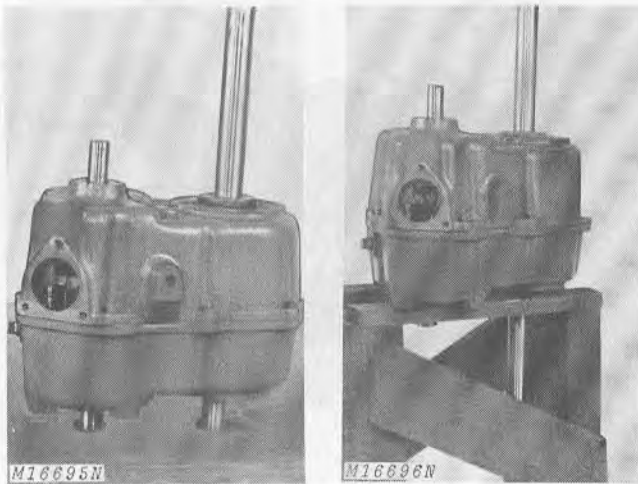
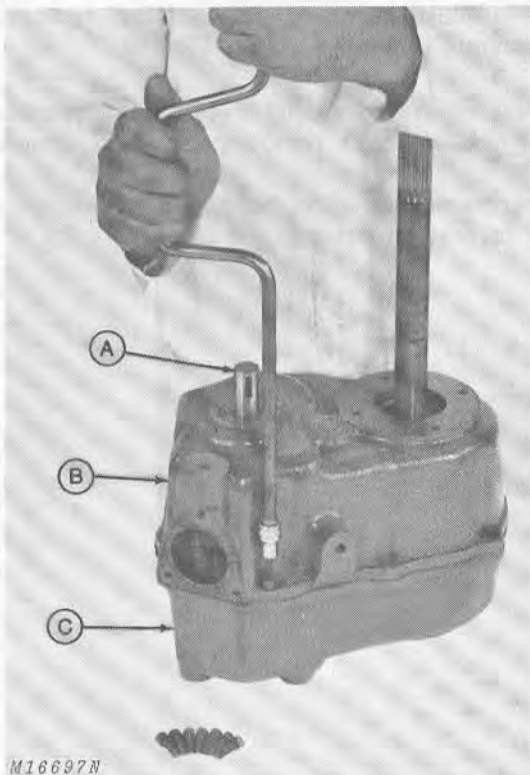

Fig. 11-Transaxle Repair Stands

Drill two 2-inch (50.80 mm) holes 8 inches (203.2 mm) apart in a sturdy work bench or stand, Fig. 11.



A—Input Shaft B—Case C—Cover

Fig. 12-Removing Case Screws

Place transaxle in bench or stand with socket-head cap screws and input shaft (A) upward. Remove eight screws.

Grasp the input shaft (A), Fig. 13, and the transaxle case. Lift case (B) slowly and shake lightly so all loose parts remain in cover (C).

Litho in U.S.A.

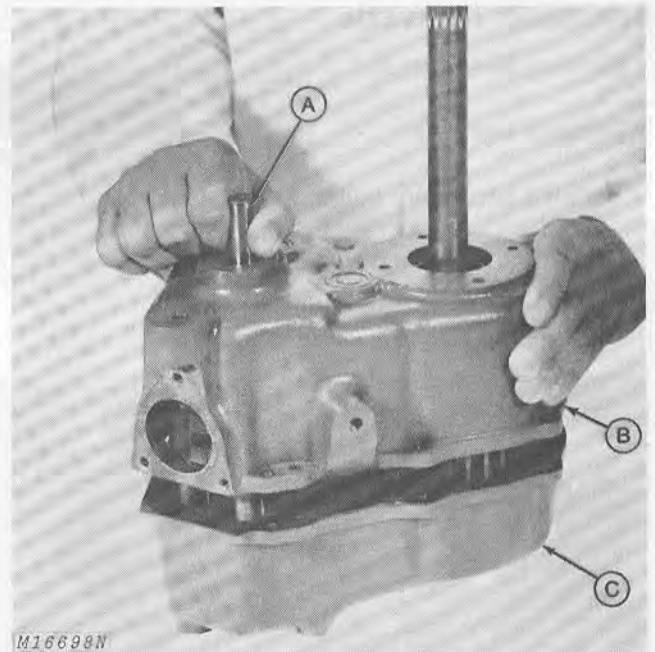

A—Input Shaft B—Case C—Cover

Fig. 13-Removing Cover

Removing Internal Components

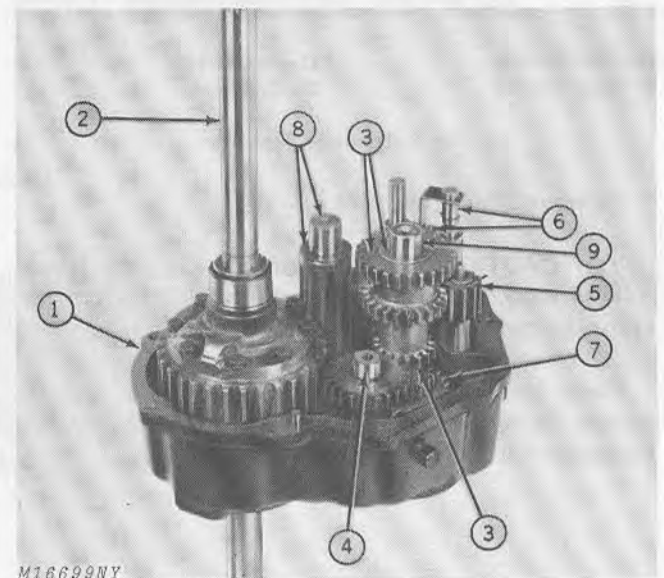

Fig. 14-Gear Removal Sequence

Figs. 14 and 15 will identify the group assemblies for the 4-speed transaxle. Lift them from the case in the following order.

1. Gasket.
2. Differential and axle assembly.

3. Washer, 3-cluster gear, and spacer from shaft and pinion brake.
4. Gear pinion and washer.
5. Reverse idler assembly.
6. Shifter rod and shaft assembly.
7. 2-cluster gear.
8. Output shaft and washers (one at each end of shaft).
9. Shaft and pinion, idler gear and washer.
10. Input shaft, Fig. 15.

NOTE: Input shaft, Fig. 15, is installed with a press fit. If close inspection reveals that gears and bearing are satisfactory, do not remove input shaft.

If it is necessary to remove the input shaft, do not use the case itself to support any of the pressure required to separate the input assembly or brake shaft assembly from the case halves. Use a large pipe to support the pinion and press the shaft from the opposite side.

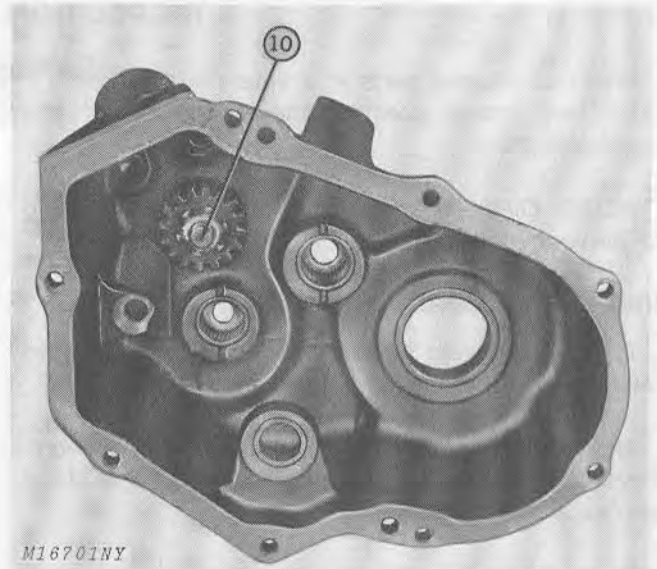
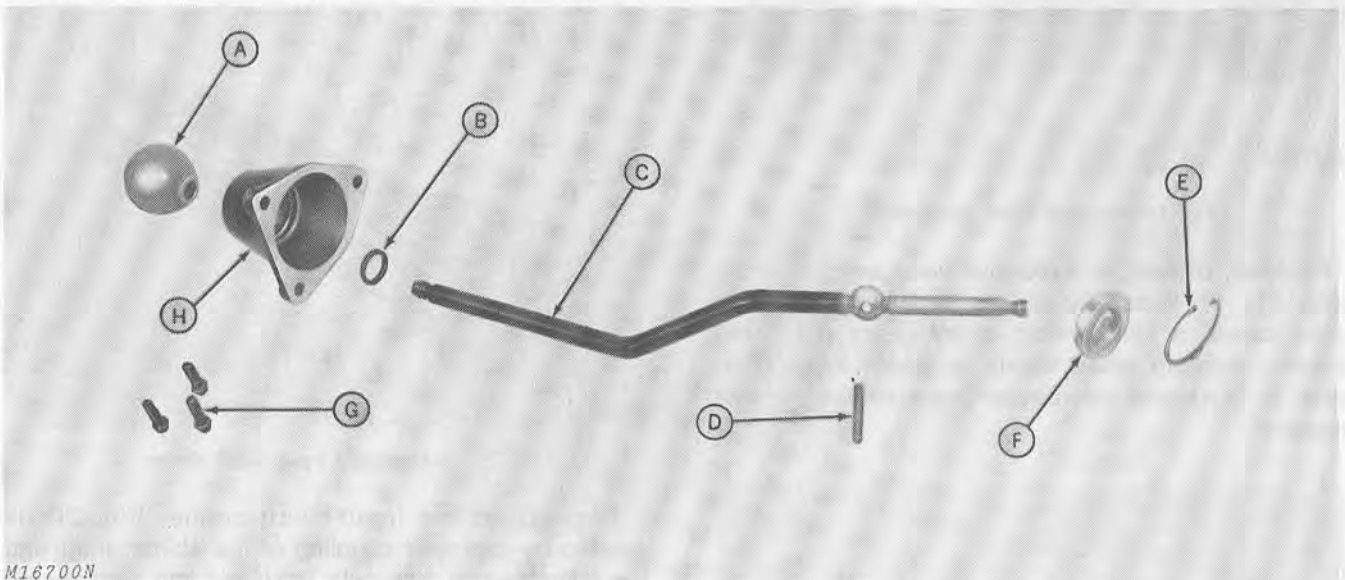

Fig. 15-Gear Removal Sequence

Disassembling Shifter Lever



- A—Shift Knob
- B—Rubber Seal
- C—Shift Lever
- D—Spring Pin

- E—Snap Ring
- F—Shift Lever Keeper
- G—Cap Screws
- H—Shifter Housing

Fig. 16-Shift Lever Components

To disassemble shift lever, Fig. 16, remove snap ring (E) in shifter housing (H) and slide assembly apart.

INSPECTION AND REPAIR

Wash all internal parts in a safe cleaning solvent. Brush and scrape foreign matter from all parts and dry thoroughly.

NOTE: Oil the bearings immediately after cleaning to prevent rusting.

Inspecting Gears and Shafts

Replace all gears having chipped, broken, or worn teeth. Badly scored gears must be replaced.

Replace any shaft that is bent, scored, or worn. Replace any shaft showing side wear or if any of the splines are damaged.

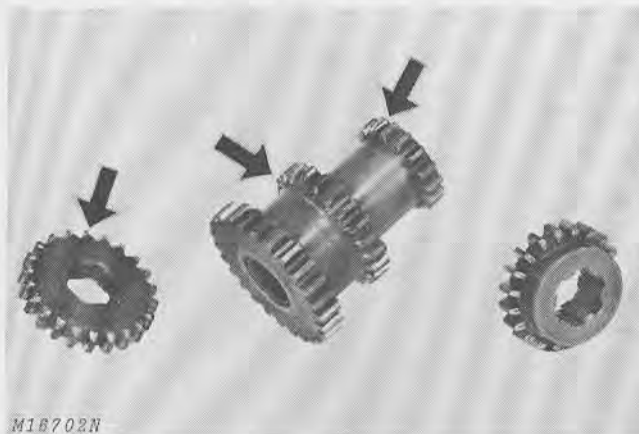

Fig. 17-Transaxle Gear Tooth Wear

Chipped, broken, or excessive wear on gear teeth ends, Fig. 17, is usually caused by shifting transaxle while tractor is still moving or by gears not being properly meshed when tractor is under load. Gear wear as illustrated can cause gears to jump out of position.

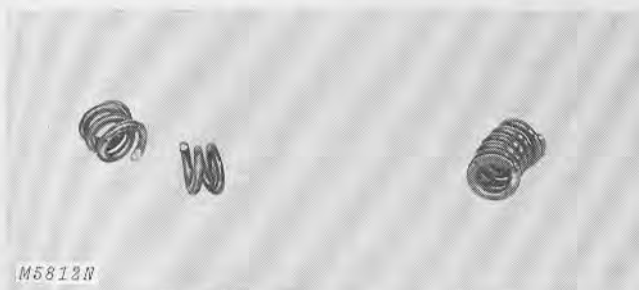

Fig. 18-Broken Detent Springs

Broken detent springs, Fig. 18, can cause gear damage. When the springs are broken, the shifter fork is free to move, thus allowing gear pressure to slide the gears out of mesh.

When the gears slide out of gear, especially under load, gear chipping or cracking will result.

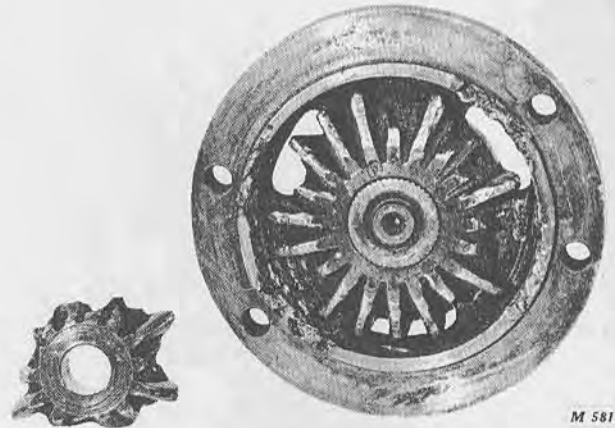

Fig. 19-Damaged Bevel Pinion Gears

Prolonged heavy drawbar loads and wheel slippage are the most common cause of bevel pinion gear failure, Fig. 19, in the differential section of the transaxle.

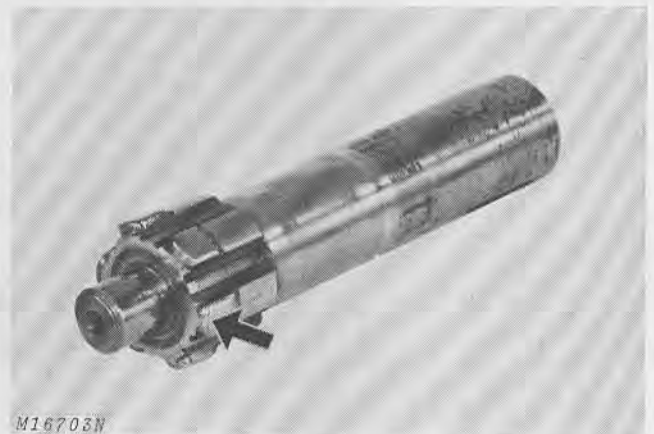

Fig. 20-Damaged Input Shaft Spline

Damage to the input shaft spline, Fig. 20, is caused by improper coupling of the shifter shaft and input shaft when transaxle is shifted into high range. A broken detent spring or an improperly adjusted quadrant are normally the cause of improper coupling.

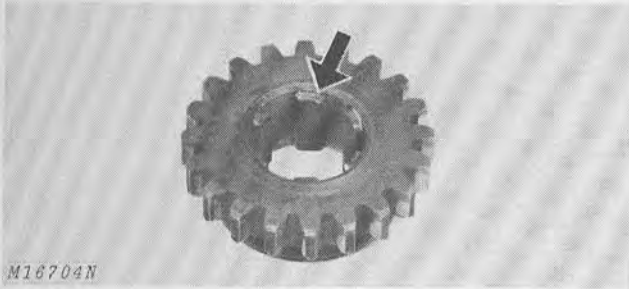

Fig. 21-Worn Spline in Shifter Gear

A damaged shifter gear spline as shown in Fig. 21 is caused by improper coupling of the shifter and input shaft. A worn or damaged shifter gear will cause gear jump-out when the tractor is operated in high range or under heavy drawbar loads.

Inspecting Oil Seals and O-Rings

Always replace oil seals in axle housings whenever transaxle is disassembled. Always use new O-rings on axle housings.

Refer to "Bearing Analysis," pages 20-20-11 and 20-20-12 for bearing and seal examination.

Inspecting Transmission Case

Inspect the transmission case halves for cracks, worn or damaged bearing bores, damaged threads, and case mating surfaces.

Inspecting Shifter Assembly

Check condition of the shifter forks, shift rods, and detent springs. Slide forks along the shaft to inspect grooves. If a good snap is felt in each detent position, disassembly is not necessary.

Inspecting Drive Blocks

Check condition of differential drive blocks. Replace if cracked or broken.

ASSEMBLY

Bevel Gear Differential

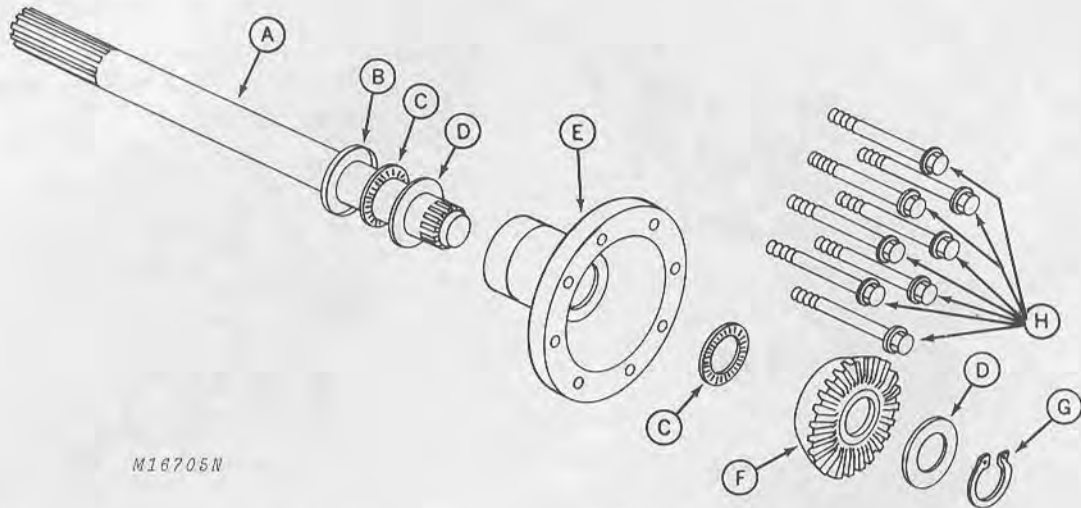

- | | | | |
|------------------------|----------------------|-------------|--------------|
| A—Axle Shaft | C—Bearings | E—Carrier | G—Snap Ring |
| B—Cupped Thrust Washer | D—Flat Thrust Washer | F—Side Gear | H—Cap Screws |

Fig. 22—Exploded View of Differential Assembly

To assemble the bevel gear differential, install the components on the axle shaft (A) in the order shown in Fig. 22. Secure with snap ring (G).

Position the thrust washers (B and D) exactly as shown in Fig. 22. It is important that the cupped thrust washer (B) be placed onto axle first.

The axles (A) should rotate freely in opposite directions when assembled. Place the differential aside for later installation.

Bearings

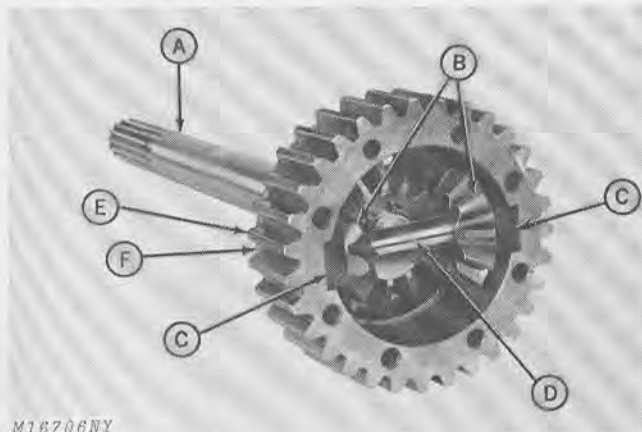

- | | |
|----------------|----------------|
| A—Axle Shaft | D—Pinion Shaft |
| B—Pinion Gears | E—Ring Gear |
| C—Drive Blocks | F—Carrier |

Fig. 23—Assembling Ring and Pinion Gears

Place ring gear (E), Fig. 23, onto one of the carriers (F) and install the pinion gears (B), pinion shaft (D), and drive blocks (C).

Position the other carrier and install the eight cap screws and lock washers. Tighten cap screws to 8 to 10 ft-lbs (10.8 Nm to 13.6 Nm) torque.

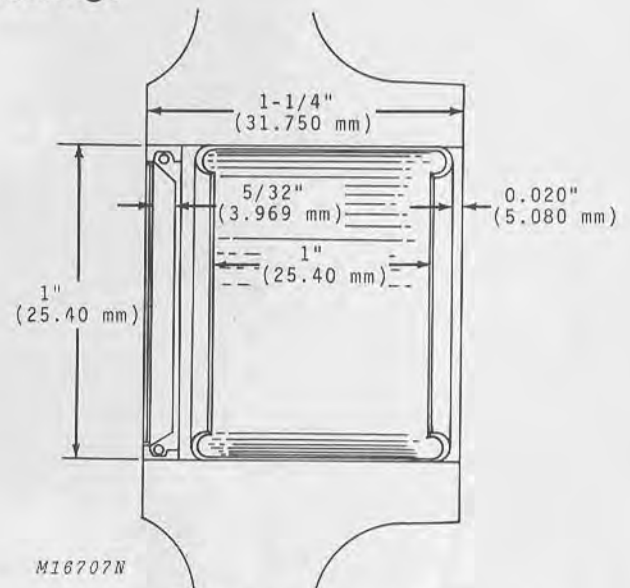
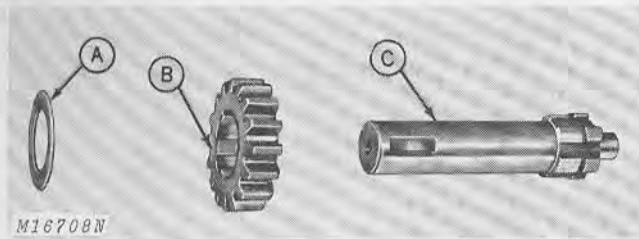

Fig. 24—Installing Bearings

All bearings are pressed into the bearing bores from the inside of the axle housing interior, Fig. 24.

Bearing drivers to install bearings properly are listed in Section 80—"Special Tools," page 80-15-1. As a general rule, all bearings should be pressed into the housing to a depth of 0.020 inch (5.080 mm) beyond flush with housing interior.

Input Shaft and Gear



A—Thrust Washer
B—Chamfered Gear Spline
C—Input Shaft

Fig. 25—Input Shaft and Gear

Assemble input shaft (C), gear, and thrust washer (A). Chamfered gear spline (B) must be toward outer end of shaft (C) as shown in Fig. 25. Gear is a light press fit onto shaft.

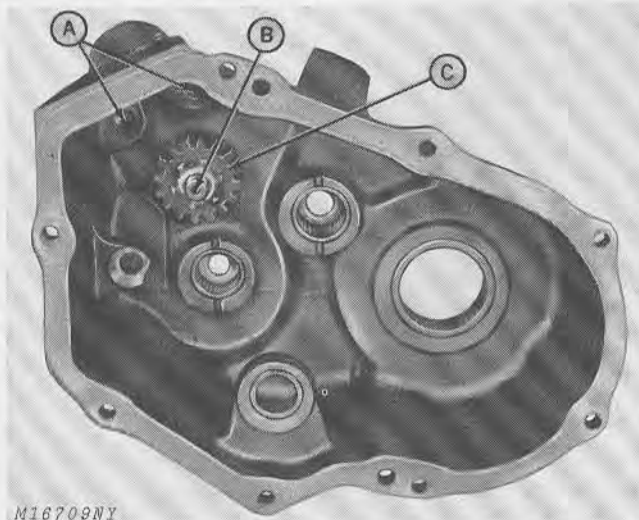

A—Shifter Rod Sockets
B—Washer, Input Shaft and Gear Assembly
C—Flat Side of Gear

Fig. 26—Assembled Input Shaft

Install washer, input shaft and gear assembly (B) into case as shown. Use special tool to protect seal when slipping shaft through seal. Refer to Section 80 - "Special Tools" for proper seal sleeve. Flat side of gear (C) should now face upward, Fig. 26.

Idler Gear and Pinion Shaft

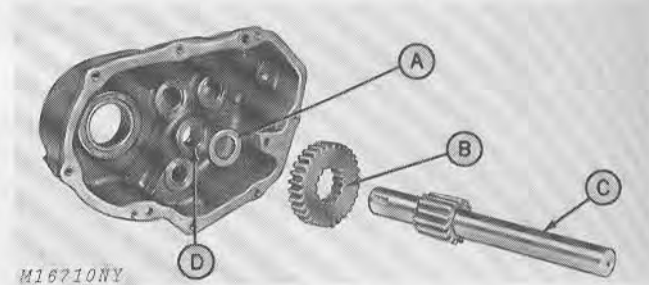

A—Thrust Washer
B—Idler Gear
C—Pinion Shaft
D—Pinion Shaft Bearing
E—Beveled Edge on Teeth

Fig. 27—Idler Gear and Shaft

Use seal sleeve tool listed in Section 80 - "Special Tools", and assemble thrust washer (A), idler gear (B), and pinion shaft (C) as shown in Fig. 27. Beveled edge on teeth (E) must face away from pinion shaft (C) as shown. Pinion shaft is a light press fit through idler gear.

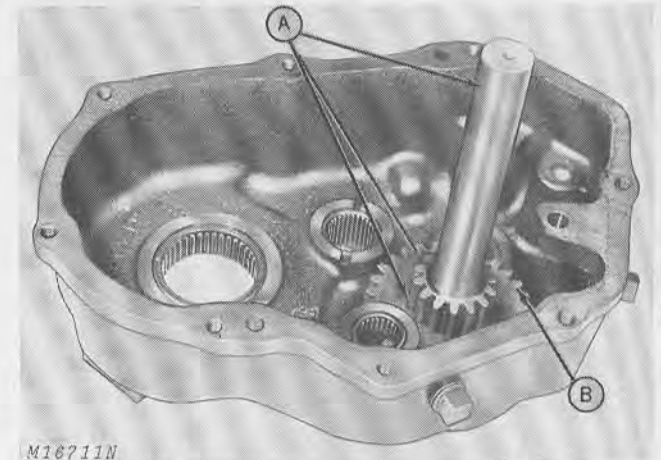

A—Pinion Shaft, Idler and Washer B—Flat Edge of Gear Up

Fig. 28—Idler Gear and Shaft Assembly

When thrust washer, idler gear, and pinion shaft (A) are properly assembled and installed, they will appear as shown in Fig. 28. The flat edge of the idler gear (B) should now face upward.

Output Shaft and Gear

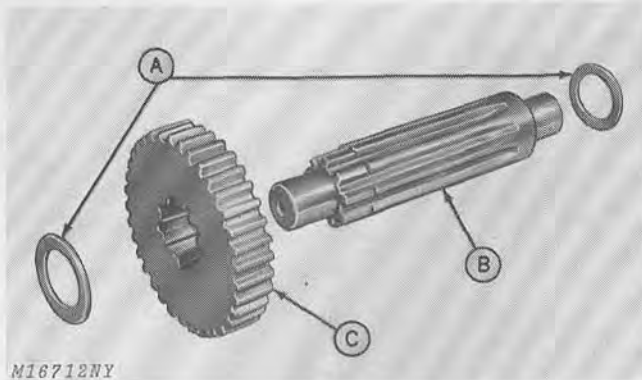

A—Thrust Washer B—Output Pinion Shaft C—Output Gear

Fig. 29-Output Shaft and Gear Assembly

The output gear (C) is assembled on the output pinion shaft (B) with a press fit. Thrust washer (A) is used on both ends of output shaft, Fig. 29.

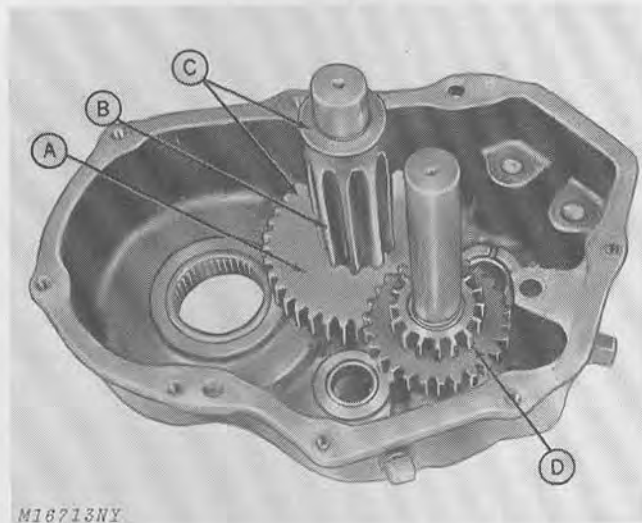

A—Output Gear
B—Pinion Shaft
C—Thrust Washers
D—Compound Gear with Bushing

Fig. 30-Output Shaft and Gear Installed

Install output gear (A), pinion shaft (B), and thrust washers (C) into left-hand case, Fig. 30.

Install compound gear with bushing (D) into left-hand case.

Shifter Components

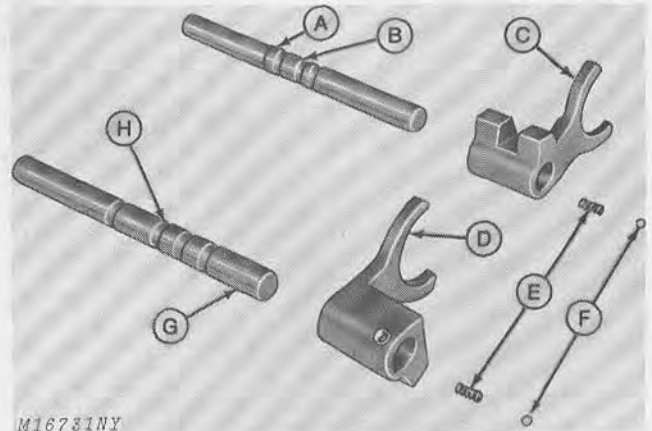

A—Snap Ring
B—3rd and 4th Shifter Rod (3 Detents)
C—3rd and 4th Shifter Fork
D—1st, 2nd and Reverse Shifter Fork
E—Detent Springs
F—Detent Balls
G—Short End of Rod
H—1st, 2nd and Reverse Shifter Rod (4 Detents)

Fig. 31-Shifter Components

Because of heavy detent pressure, the assembly of these rods can be difficult. Assemble forks as shown in Fig. 31.

1st, 2nd and reverse fork (D) is assembled onto the shifter rod (H) so the fork will face away from the short end of the rod (G).

The 3rd and 4th shifter rod (B) must have the end opposite snap ring (A) toward fork when assembled as shown in Fig. 31.

To assemble rod into forks, depress detents and slide forks along rod. A good snap should be felt in each detent. Place forks in neutral positions at this time as shown in Fig. 32, page 50-20-13.

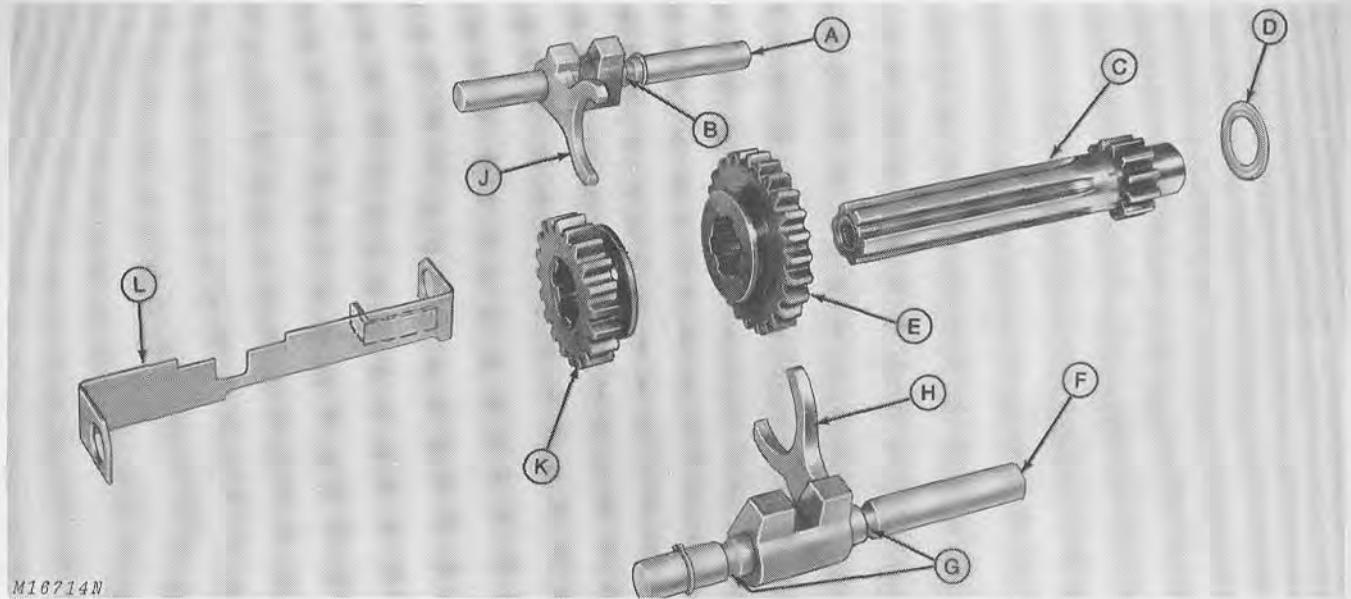

A—3rd and 4th Shifter Rod
B—Neutral Position (One Detent)
Showing Between Fork and
Snap Ring
C—Shifter Shaft
D—Thrust Washer

E—1st, 2nd and Reverse Shifter Gear
F—1st, 2nd and Reverse Shifter Rod
G—Neutral Position (Two Detents
Showing)
H—Fork 1st, 2nd and Reverse

J—Fork 3rd and 4th
K—3rd and 4th Shifter Gear
L—Shifter Guide

Fig. 32-Shifter Shaft and Gear Components

To assemble shifter, lay out parts as shown in Fig. 32. Place forks (H) and (J) in neutral position.

First, second, and reverse shifter rod (F) will have one detent showing on each side of fork (G), Fig. 32.

Third and fourth shifter rod (A) will have one detent showing between fork and snap ring (B), Fig. 32. Be sure shifter rod (F) with detent showing on each side of fork is used with 1st, 2nd and reverse shifter gear (E), and shifter rod (A) is used with 3rd and 4th shifter gear (K).

The shifter shaft assembly should appear as shown in Fig. 33. The slot (E) in the forks should line up when the large gear (F) is slipped as far as possible on the spline. Note the position of the exposed grooves on shifter rods (C) and (D), Fig. 33.

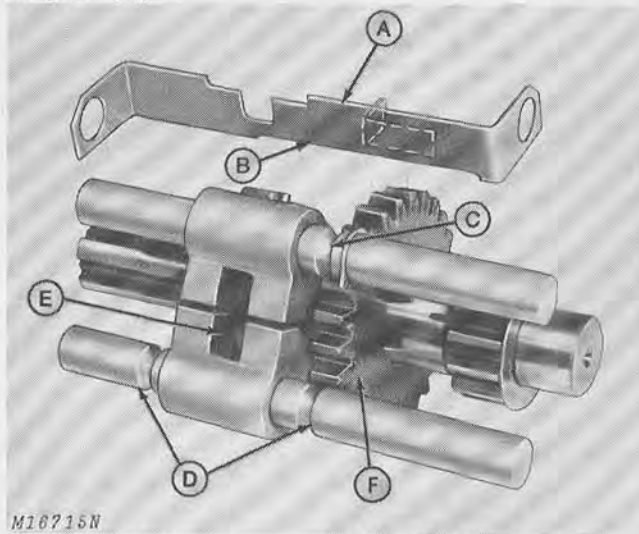

A—Shifter Guide
B—Long Notch
C—Shifter Rod Neutral
Position
D—Shifter Rod Neutral
Position
E—Slot (Forks)
F—Large Gear

Fig. 33-Shifter Assembly

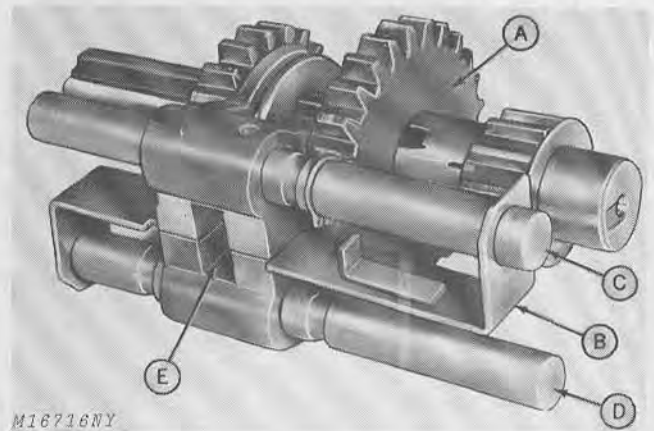

A—1st, 2nd and Reverse
Shifter Gear
B—Shifter Guide
C—Shifter Rod
D—Shifter Rod
E—Slot in Guide

Fig. 34-Shifter Assembly

Assemble shifter guide (B), Fig. 34, over shifter rods (C) and (D). Slot in guide (B) should match rectangular opening between the forks (E). The long notch in underside of guide (B) should clear the large 1st, 2nd and reverse shifter gear (A).

Shifter Components—Continued

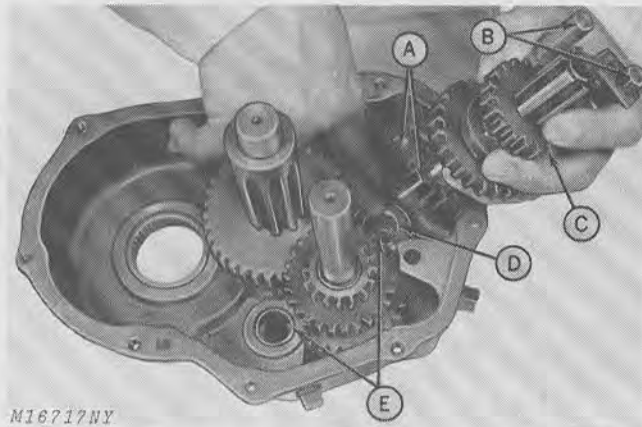

M16717NY

- | | |
|--------------------|------------------|
| A—Sockets | D—Thrust Washer |
| B—Shifter Rods | E—Needle Bearing |
| C—Shifter Assembly | |

Fig. 35-Shifter Installation

Place thrust washer (D) over needle bearing (E). Grasp shifter assembly (C) in left hand and lower it into case.

The shifter rods (B) should now enter the two machined sockets (A) in left-hand case.

Idler Gear, Pinion and Thrust Washer

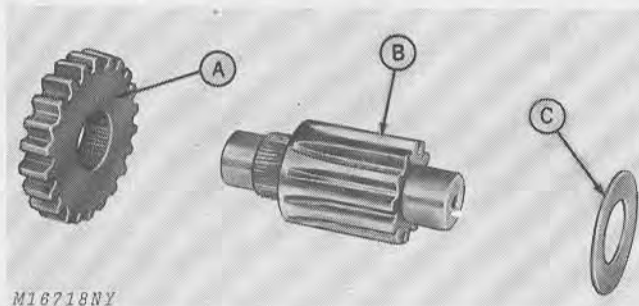

M16718NY

- | | | |
|--------------|----------------------|-----------------|
| A—Idler Gear | B—Idler Pinion Shaft | C—Thrust Washer |
|--------------|----------------------|-----------------|

Fig. 36-Idler Components

The inside of the idler gear (A) is splined to slip freely onto splined end of idler pinion shaft (B), Fig. 36.

Reverse Idler Shaft and Gear

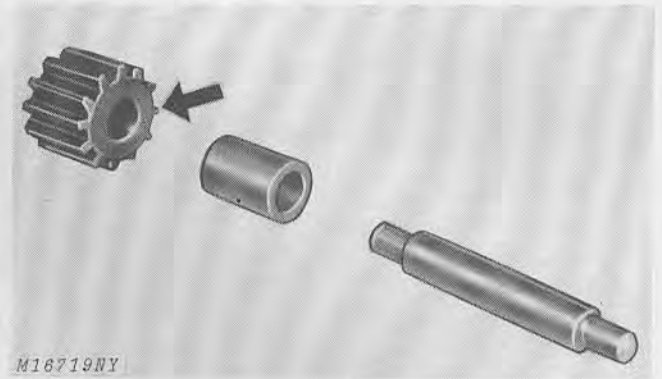

M16719NY

Fig. 37-Reverse Idler Components

Assemble reverse idler shaft as illustrated with rounded edge of teeth facing spacer, Fig. 37.

Reverse Idler, Idler Gear Assembly and Spacer

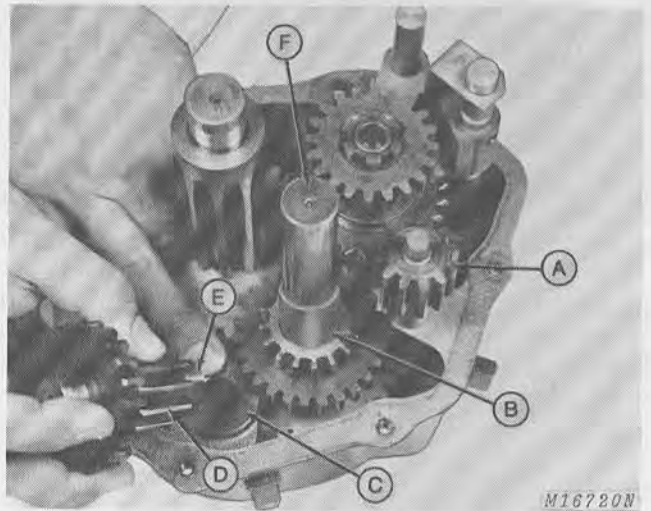

M16720N

- | | |
|--------------------------|----------------------|
| A—Reverse Idler Assembly | D—Idler Gear |
| B—Spacer | E—Idler Pinion Shaft |
| C—Thrust Washer | F—Pinion Shaft |

Fig. 38-Installing Idler and Reverse Idler

Install reverse idler assembly (A), Fig. 38.

Install thrust washer (C), idler pinion shaft (E), and idler gear (D).

Fig. 37 shows proper assembly before lowering into left-hand case, Fig. 38.

Place spacer (B) on pinion shaft (F), Fig. 38.

Cluster Gear and Thrust Washer

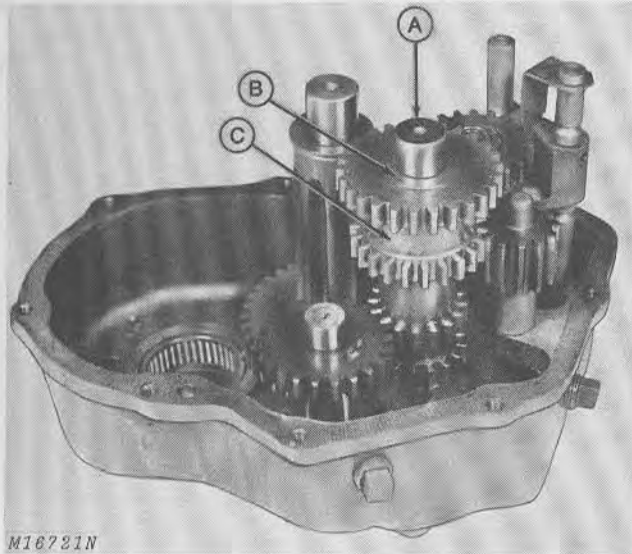

A—Pinion Shaft B—Thrust Washer C—Gear Cluster

Fig. 39-Transmission Assembled

Install gear cluster (C) and thrust washer (B) on pinion shaft (A) as shown in Fig. 39.

All parts assembled thus far should appear as shown in Fig. 39.

Installing Differential

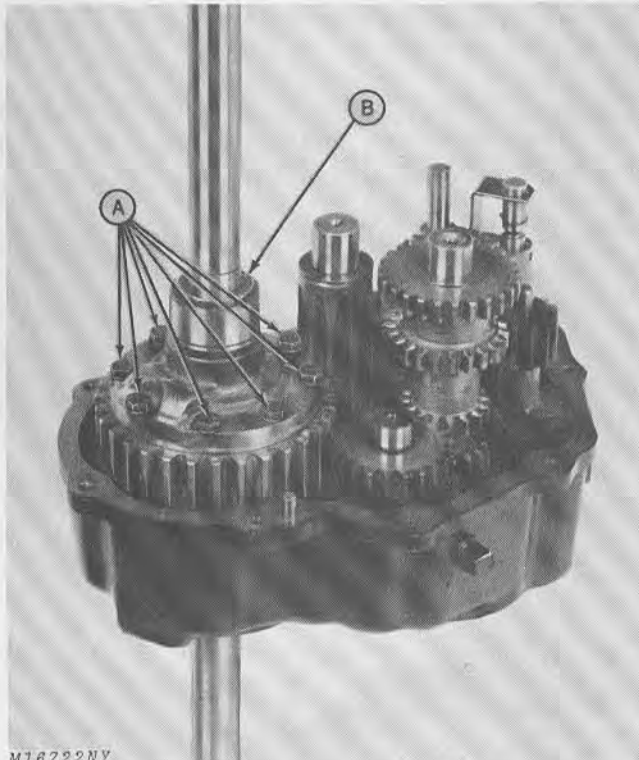

A—Cap Screws B—Differential Assembly

Fig. 40-Installing Differential

Install differential assembly (B) into left-hand case with cap screws (A) facing upward as shown in Fig. 40.

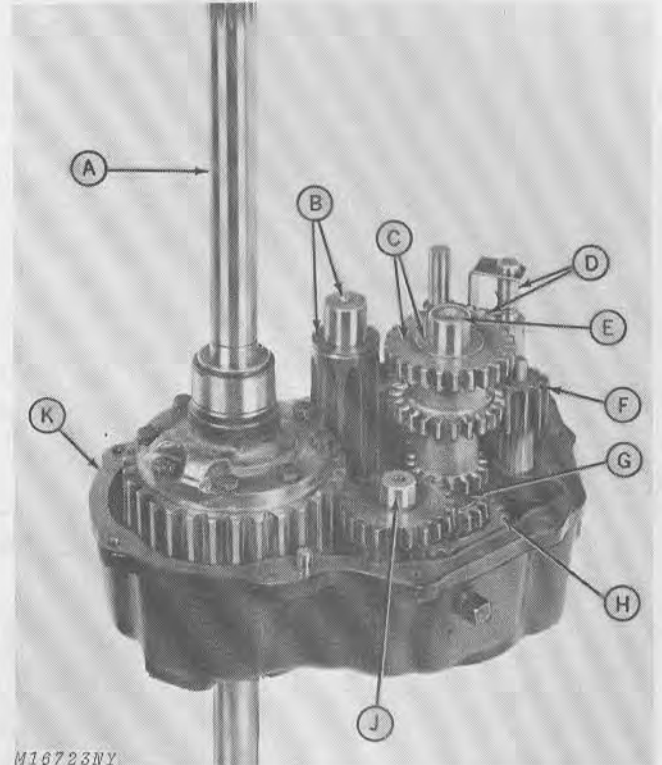

A—Differential and Axle
B—Output Shaft and Washers
C—Washer and 3-Cluster Gear
D—Shifter Rods and Shaft Assembly
E—Shaft and Pinion Brake
F—Reverse Idler Shaft and Spacer
G—Spacer
H—2-Cluster Gear
J—Gear, Pinion and Washer
K—Gasket

Fig. 41-Complete Internal Assembly

The internal components should now appear as shown in Fig. 41.

Position a new gasket (K) on lower (left-hand) case at this time.

Placing Cover on Case

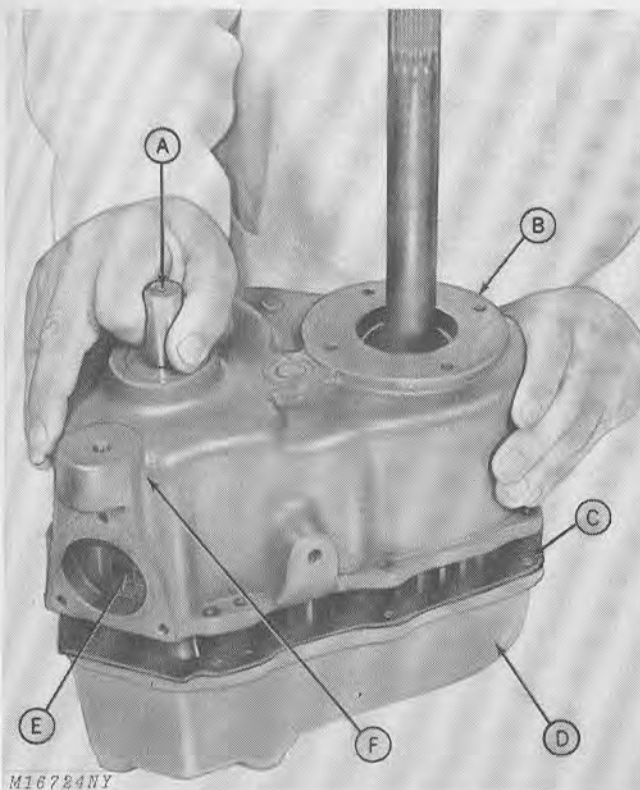

- A—Input Shaft
- B—Right-Hand Case
- C—Gasket
- D—Left-Hand Case
- E—Shifter Rods
- F—Tap Here (Horizontally)

Fig. 42—Closing Case

Install right-hand case half (B) over axle and input shaft (A), Fig. 42.

Shake case slightly to align shafts and shifter rods (E). Also a short turn of the input shaft (A) will help align shafts and gears.

To close the last one-half inch, tap the right-hand case horizontally at point (F).

If case will not close, reach through round hole in right-hand case (B) with a screwdriver and move shifter rods (E).

This will help align shifter rods (E) so they will fall into shifter rod sockets in right-hand case (B).

Installing Seals

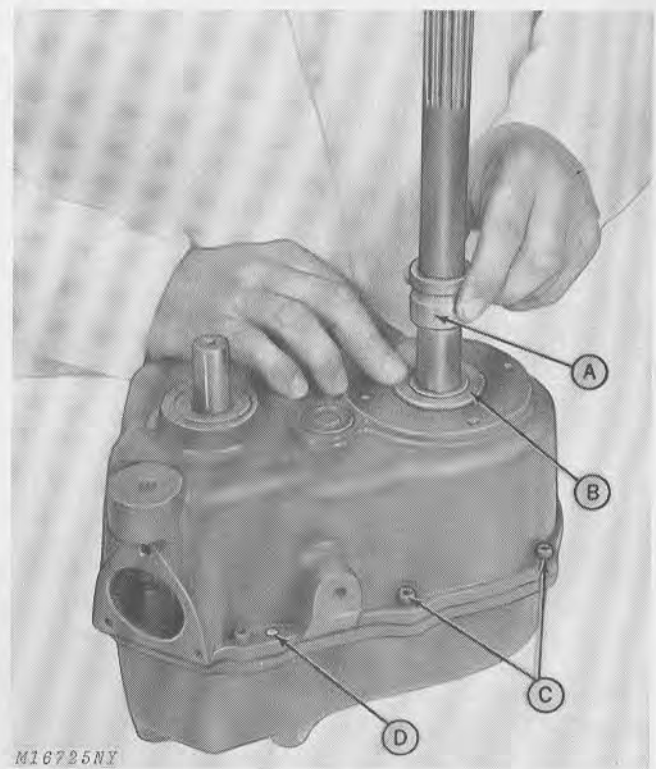

- A—Special Tool
- B—Seal and Retainer
- C—Socket Head Screws
- D—Dowel Pin

Fig. 43—Installing Retainers and Seals

Insert eight socket head screws (C), Fig. 43, and tighten to 120 in-lbs (45 Nm) torque.

Install retainer and new seal (B) with special oil seal cone tool (A), Fig. 43, to prevent cutting seal during installation.

The seal is properly installed when the open face is facing inward toward the gears.

Installing Axle Supports

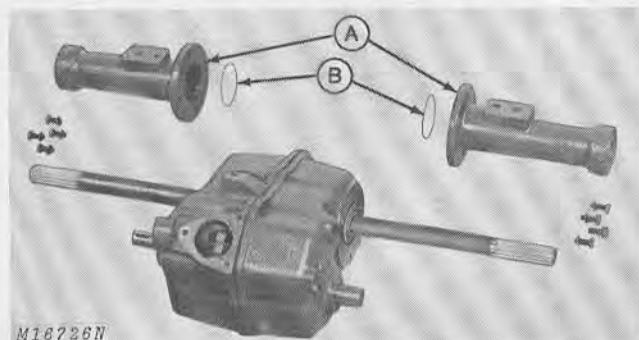

A—Axle Supports

B—O-Rings

Fig. 44—Installing Axle Supports

Install O-rings (B) and axle supports (A) with bearings as shown in Fig. 44.

Always use new O-rings. Refer to "Bolt Torque Chart" page 10-10-4 and tighten support bolts accordingly.

Positioning Shifter Forks

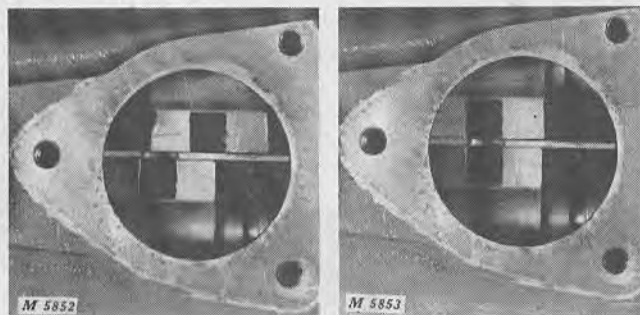

Fig. 45—Shifter Forks

Inspect the shifter forks, Fig. 45, to be sure they are aligned and in neutral position.

Failure to do this will cause damage to the transmission when engaged under power. (Compare illustrations above.)

Assembling Shifter Lever

The shifter is assembled in the order shown in Fig. 16, page 50-20-7.

When assembling shifter, be sure rubber seal is positioned properly in shifter housing. Shellac or gasket cement will hold seal in position during assembly.

Align housing, keeper and spring pin in shift lever and place snap ring in groove in shifter housing.

Tighten screws to 120 in-lbs (45 Nm) torque.

INSTALLING TRANSAXLE

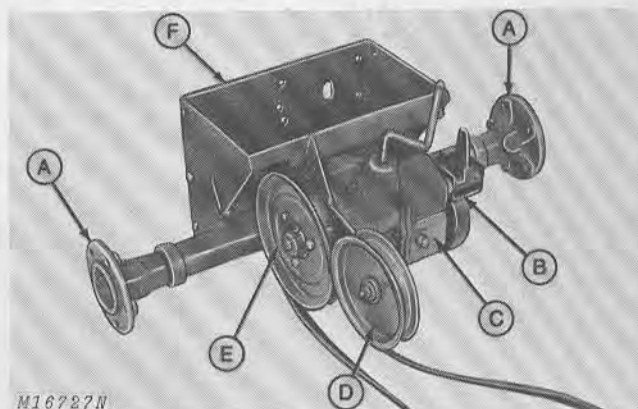

A—Wheel Hub
B—Brake Assembly
C—Transaxle

D—Secondary Idler
E—Driven Sheave
F—Hitch Plate

Fig. 46—Transaxle Installation

Before installing transaxle in tractor base, check transaxle by turning driven sheave and shifting transaxle in each gear.

Apply Loctite to threads on all set screws used in assembling components to transaxle. Refer to "Bolt Torque Chart", page 10-10-4. Tighten bolts and set screws accordingly.

TORQUE FOR HARDWARE

Item	Torque
Differential Carrier Cap Screws	25-30 ft-lbs (112-145 Nm)
Shifter Lever Housing	120 in-lbs (45 Nm)
Transaxle Case Socket Head Screws	120 in-lbs (45 Nm)

Group 25 PTO CLUTCH

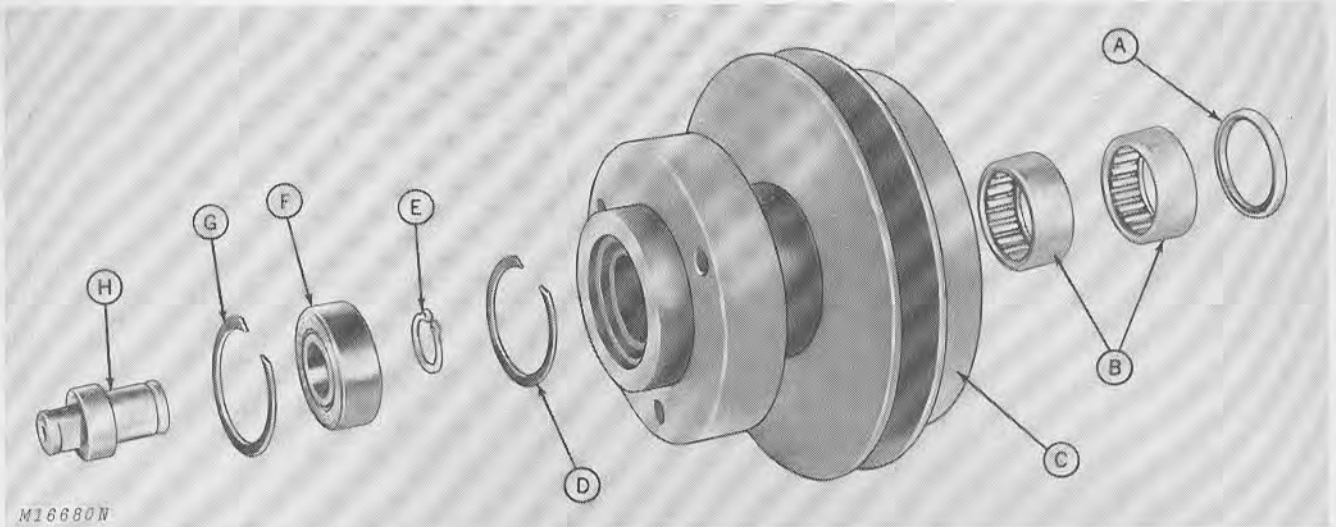

A—Seal
B—Roller Bearings
C—PTO Drive Sheave
D—Inner Snap Ring

E—Small Snap Ring
F—Ball Bearing
G—Outer Snap Ring
H—PTO Clutch Pivot

Fig. 1-PTO Clutch Drive Sheave Assembly

PRINCIPLE OF OPERATION

The manual PTO clutch is the cup and cone-type. The cone, which has the clutch lining bonded to it, is attached directly to the engine crankshaft. The cup (C), Fig. 1, slides on the crankshaft, and is controlled by the PTO clutch linkage.

Engaging the PTO clutch, slides the cup into contact with the cone, starting rotation. Disengaging the PTO clutch slides the cup out of engagement with the cone and into engagement with the brake shoe, stopping rotation.

DIAGNOSING MALFUNCTIONS

Clutch Will Not Engage

- Clutch linkage bent or broken.
- Clutch linkage out of adjustment.
- Clutch lining on fulcrum bolt worn excessively.

Clutch Will Not Disengage

- Clutch linkage bent or broken.
- Clutch linkage out of adjustment.

Clutch Will Not Stop Rapidly When Disengaged

- Clutch brake shoe out of adjustment.
- Clutch brake shoe lining worn excessively.

PTO Drive Sheave Noisy

- Drive sheave bearing dry.
- Bearing worn excessively.
- PTO clutch pivot bearing worn excessively.

REPAIR

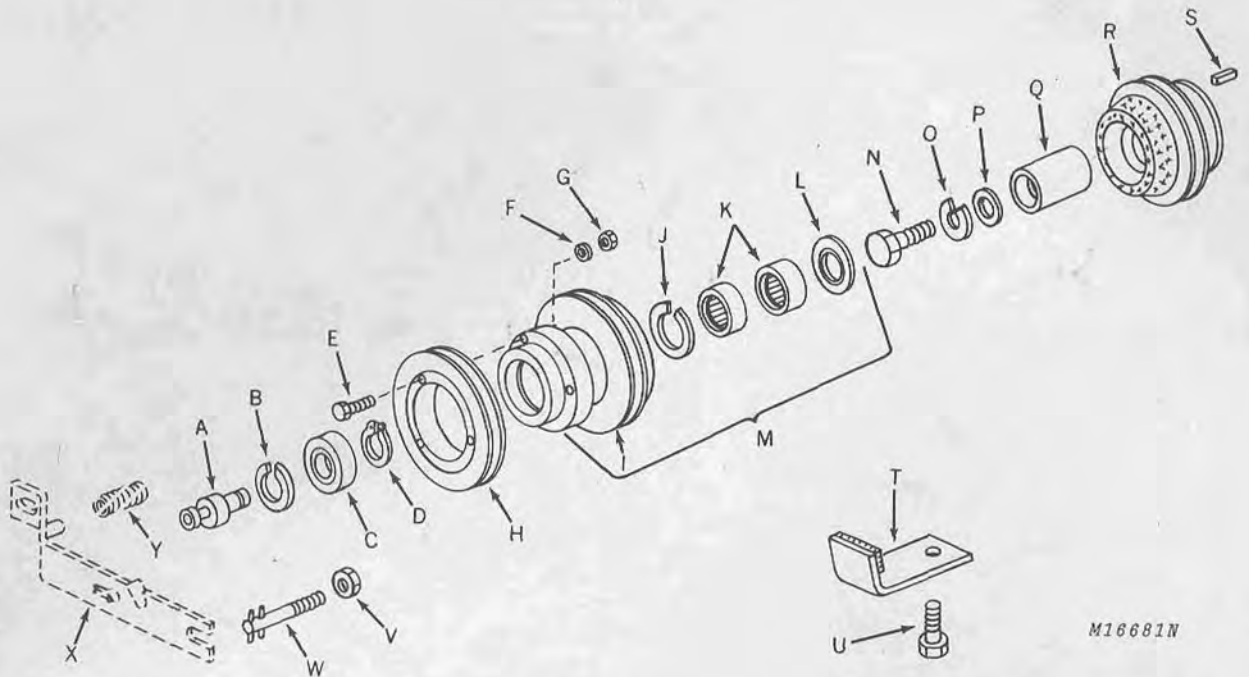

A—PTO Clutch Pivot
B—Outer Snap Ring
C—Ball Bearing
D—Small Snap Ring
E—Sheave Bolt
F—Lock Washer
G—Nut
H—Sheave
I—PTO Clutch Cup

J—Inner Snap Ring
K—Needle Bearing (2 used)
L—Oil Seal
M—PTO Clutch Cup With Bearings
N—7/16"x1-1/4" UNF
Cap Screw
O—Lock Washer
P—Retaining Washer
Q—Bearing Inner Race

R—Clutch Cone With Lining
S—Key
T—Clutch Brake Shoe
U—5/16"x1-1/4" Cap Screw and
Lock Washer
V—Lock Nut
W—Fulcrum Bolt
X—Clutch Arm
Y—Return Spring

Fig. 2—Exploded View of PTO Clutch Assembly

Disassembly

Remove clutch arm (X) from PTO clutch pivot (A) and fulcrum bolt (W). Loosen clutch brake shoe (T) to allow PTO clutch cup (M) to be removed. Remove cap screw (N) and washers (O and P) from end of crankshaft and remove bearing inner race (Q). Remove clutch cone (R) and key (S).

Remove outer snap ring (B). Press PTO clutch pivot (A) out of PTO clutch cup (I). Remove inner snap ring (J). Press two needle bearings (K) and oil seal (L) out of PTO drive sheave. Remove small snap ring (D) from PTO clutch pivot (A) and press bearing (C) off clutch pivot (A).

Inspection

Inspect clutch linings and mating surfaces for excessive wear. Inspect bearings, bearing inner race and seal. Inspect PTO brake shoe for excessive wear. Replace parts as necessary.

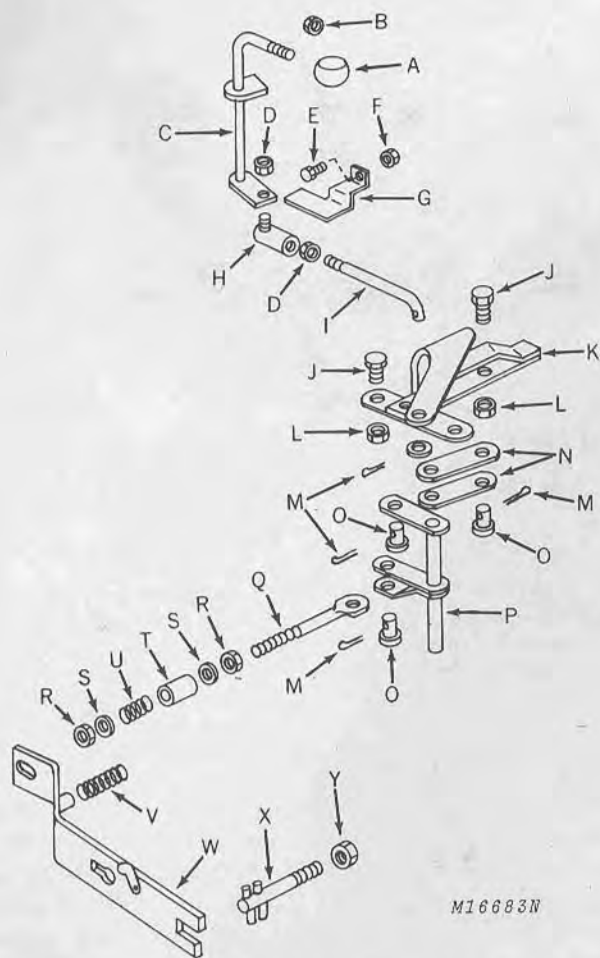

M16683N

- | | |
|-----------------------------|--------------------|
| A—Knob | N—Connecting Strap |
| B—1/2" Hex. Nut | O—Hinge Pin |
| C—Lever | P—Pivot |
| D—5/16" Hex. Nut | Q—Link |
| E—Cap Screw | R—5/16" Nut |
| F—Nut | S—Flat Washer |
| G—Locking Spring | T—Spacer |
| H—Ball Joint | U—Clutch Spring |
| I—Link | V—Return Spring |
| J—3/8" x 1-1/4" Cap Screw | W—Clutch Arm |
| K—Toggle Assembly | X—Fulcrum Bolt |
| L—3/8" Jam Nut | Y—1/2" Lock Nut |
| M—3/32" x 1-1/4" Cotter Pin | |

Fig. 3-PTO Linkage for 200 Tractor

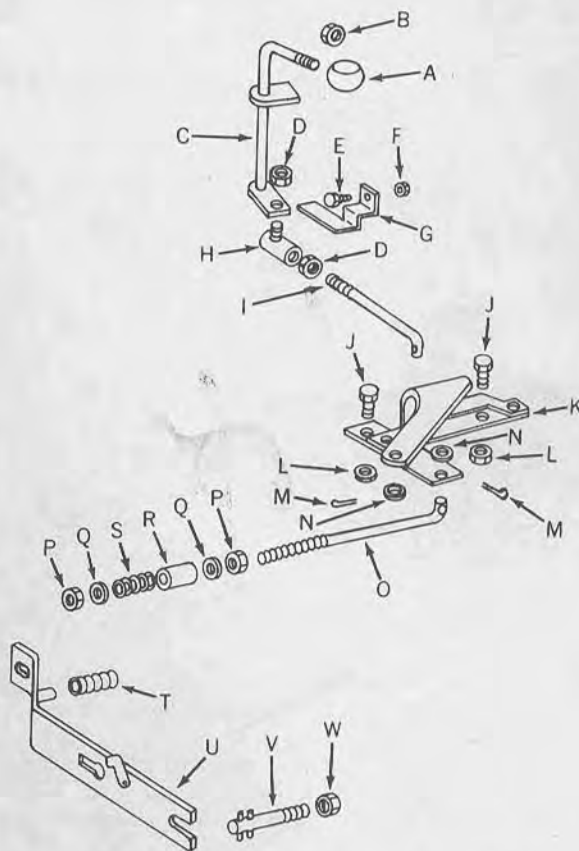

M16682N

- | | |
|---------------------------|--------------------------|
| A—Knob | M—1/8" x 3/4" Cotter Pin |
| B—1/2" Hex. Nut | N—Washer |
| C—Lever | O—Link |
| D—Nut | P—5/16" Nut |
| E—Cap Screw | Q—Flat Washer |
| F—Nut | R—Spacer |
| G—Locking Spring | S—Clutch Spring |
| H—Ball Joint | T—Return Spring |
| I—Link | U—Clutch Arm |
| J—3/8" x 1-1/4" Cap Screw | V—Fulcrum Bolt |
| K—Toggle Assembly | W—1/2" Lock Nut |
| L—3/8" Jam Nut | |

Fig. 4-PTO Linkage for 210, 212 and 214 Tractors

Inspect clutch linkage, springs and all connections to be certain nothing is bent, broken, loose or stretched.

ASSEMBLY



A—Clutch Cone With Brake Lining
 B—Bearing Inner Race
 C—Cap Screw

Fig. 5—Clutch Cone and Bearing Inner Race Assembly

Install key in crankshaft and slide clutch cone (A) onto crankshaft, Fig. 5.

Install bearing inner race (B), retaining washer, lock washer and cap screw (C), Fig. 5. Tighten cap screw securely.

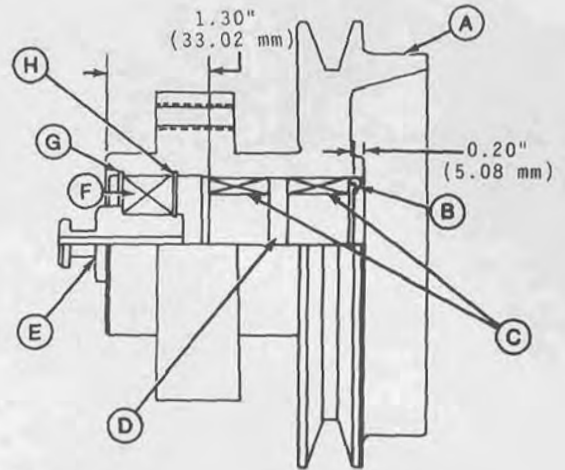

M16685N

A—PTO Drive Sheave
 B—Seal (Lip Inward)
 C—Roller Bearings
 D—Pack This Area With Grease
 E—Clutch Pivot
 F—Ball Bearing
 G—Outer Snap Ring
 H—Inner Snap Ring

Fig. 6—PTO Drive Sheave Assembly Detail

Press bearings (C) and seal (B) into PTO drive sheave (A) to dimension given in Fig. 6. Pack area (D) with John Deere High-Temperature Grease or equivalent. See page 10-15-3. Press clutch pivot (E) into ball bearing (F) and secure with small snap ring (not illustrated). Install inner snap ring (H) into PTO drive sheave (A). Secure clutch pivot and ball bearing assembly in place with outer snap ring (G).

Slide complete PTO clutch sheave assembly onto bearing inner race.

ADJUSTMENTS

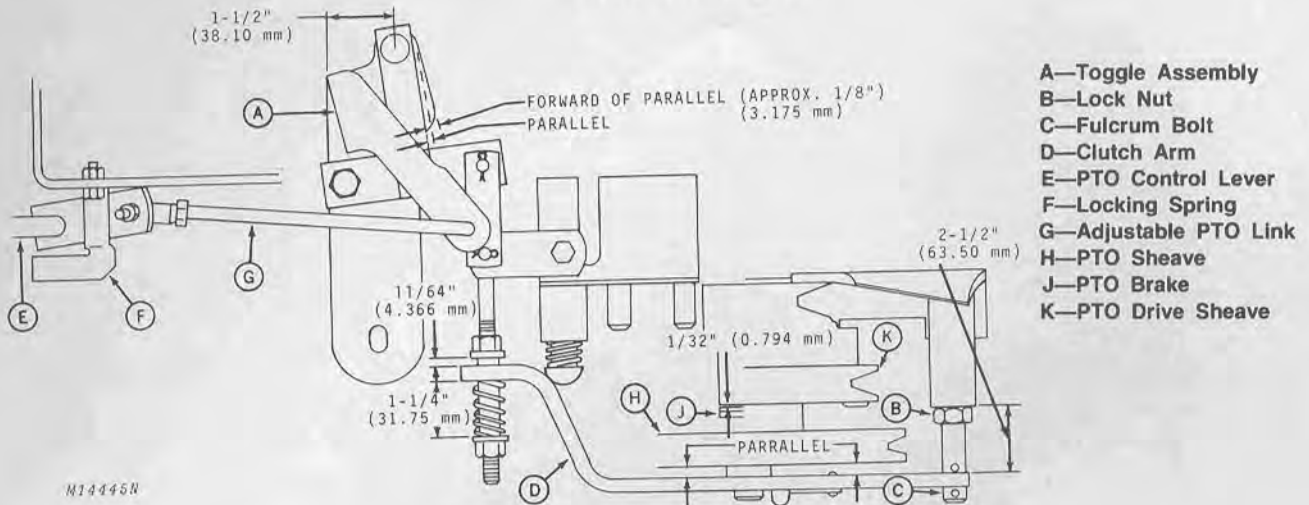

M14446N

Fig. 7-Top View of PTO Linkage—200 Tractor

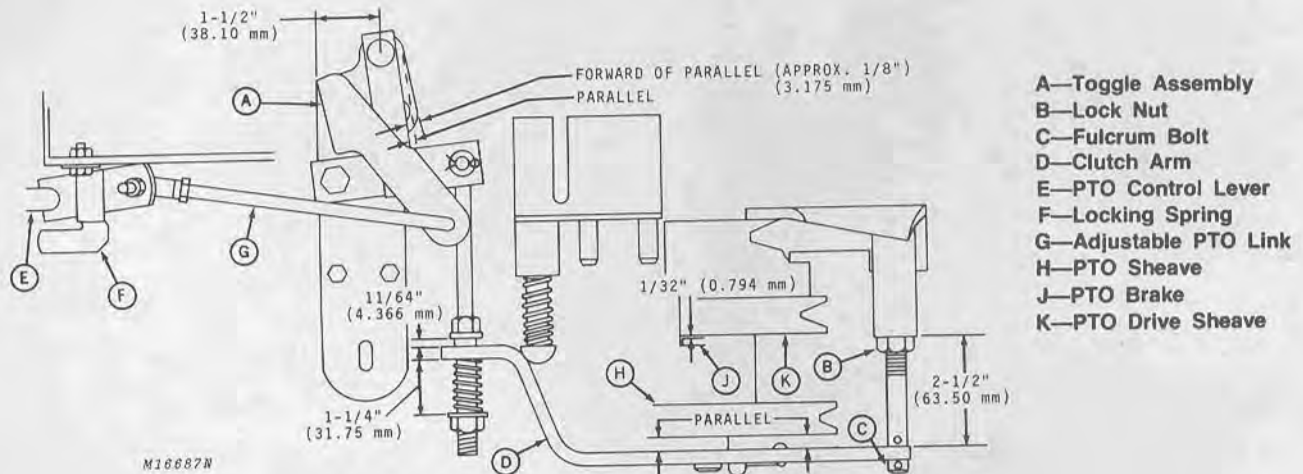

M16687N

Fig. 8-Top View of PTO Linkage—210, 212 and 214 Tractors

Adjust length of PTO link (G) so the PTO lever points forward and the toggle (A) is overcenter approximately 1-1/2 inches (38.10 mm) or 1/8-inch (3.175 mm) forward of parallel as shown, Figs. 7 or 8.

Adjust the fulcrum bolt (C) to a preliminary setting of 2-1/2 inches (63.50 mm) from the back of the lock nut (B) to the inside of clutch arm (D), Fig. 7 or 8.

Adjust the clutch spring so when the PTO is in the engaged position the distance from the clutch arm

(D) to the outside washer is 1-1/4 inches (31.75 mm).

Readjust the fulcrum bolt (C) and clutch spring if necessary to maintain a parallel condition between the clutch arm (D) and PTO sheave (H) with the PTO engaged.

After the clutch adjustments have been made, adjust the PTO brake (J) for a 1/32-inch (0.794 mm) gap between the brake pad and the PTO drive sheave (K) with the PTO engaged.

Section 60
HYDRAULIC SYSTEM
Group 5
GENERAL INFORMATION

CONTENTS

	Page		Page
GROUP 5 - GENERAL INFORMATION		GROUP 15 - PUMP	
Principle of Operation	5-2	Principle of Operation	15-1
Testing System Pressure	5-3	Removal	15-2
Diagnosing Malfunctions	5-4	Disassembly	15-2
GROUP 10 - CONTROL VALVE		Inspection	15-4
Principle of Operation	10-1	Assembly	15-5
Removal	10-2	GROUP 20 - CYLINDER	
Disassembly	10-3	Principle of Operation	20-1
Inspection	10-3	Removal	20-2
Assembly	10-4	Installation	20-3

PRINCIPLE OF OPERATION

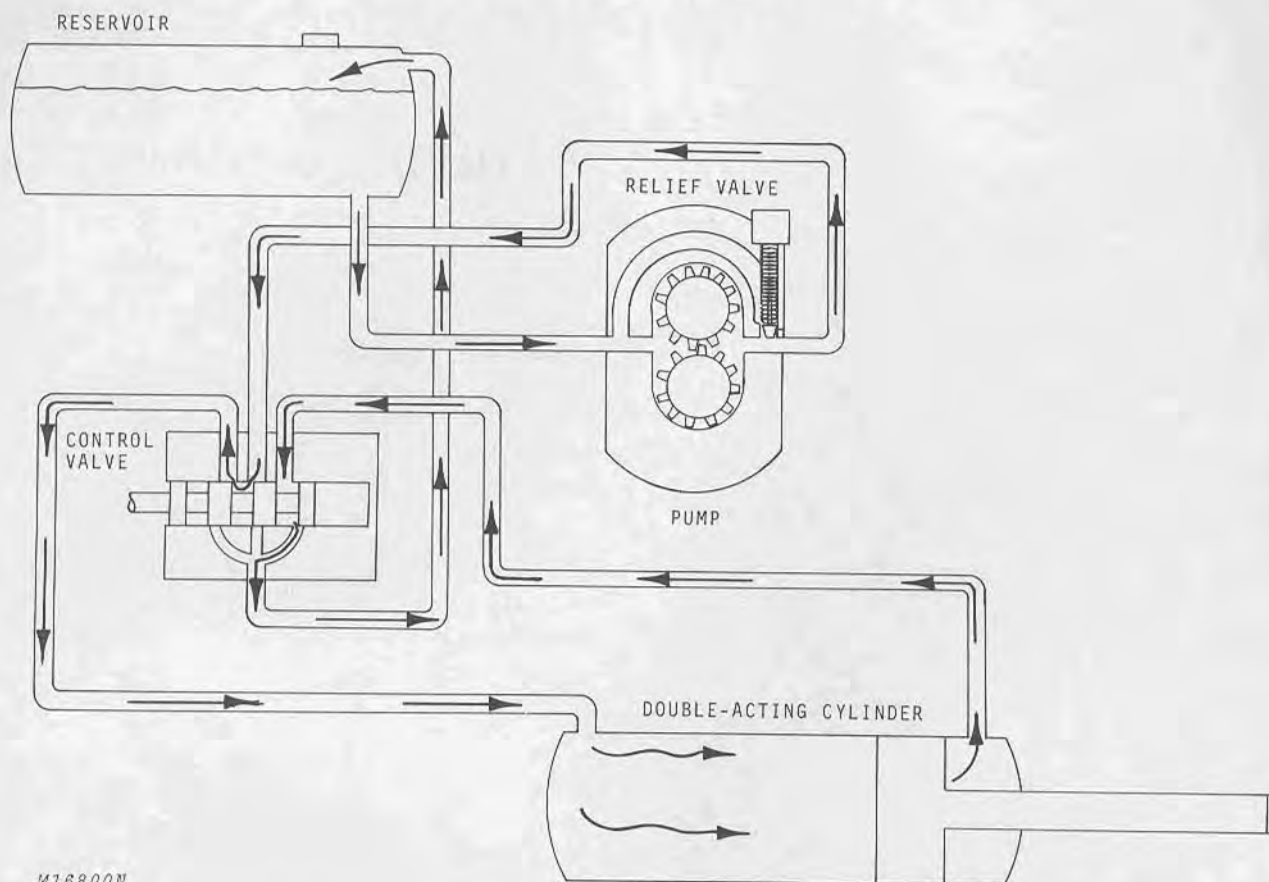

M18800N

Fig. 1-Open-Center Hydraulic System

A hydraulic lift system is available for 210, 212, and 214 Tractors as a dealer installed accessory. The hydraulic lift consists of a positive displacement pump (Parker Hannifin), control valve, double-acting cylinder, reservoir and hoses.

With this open-center system there is a continuous flow of oil from the reservoir to pump through the control valve back to the reservoir in the neutral position.

When the control valve is actuated, pressure oil from the pump is directed to either side of the double acting cylinder. As pressure oil moves the piston through its stroke, oil from the other side of the piston leaves the cylinder and enters the control valve and is directed back to the reservoir.

The direction of oil flow is changed in the control valve. The lift lever moves the spool and close the correct parts to direct the oil to the cylinder. When the lever is released, it will return to the neutral position. At this time the oil at either side of the piston is trapped, locking the piston rod in place.



Fig. 2-Reservoir

The reservoir mounted inside the pedestal has a one quart capacity.

When servicing the hydraulic system, remove the filler cap and check the fluid level. The fluid level should be 1 inch (24.4 mm) from the top of the reservoir. When required, add John Deere All-Weather Hydrostatic Fluid or Type "F" Automatic Transmission Fluid.

The hydraulic system lubricant does not require periodic changing. However, if the unit is disassembled for service, add one quart of new oil.

IMPORTANT: Never allow dirt to enter the hydraulic system.

CAUTION: Escaping fluid under pressure can have sufficient force to penetrate the skin, causing serious personal injury. Before disconnecting lines, be sure to relieve all pressure. Before applying pressure to the system, be sure all connections are tight and that lines, pipes and hoses are not damaged. Fluid escaping from a very small hole can be almost invisible. Use a piece of cardboard or wood, rather than hands, to search for suspected leaks.

If injured by escaping fluid, see a doctor at once. Serious infection or reaction can develop if proper medical treatment is not administered immediately.

TESTING SYSTEM PRESSURE

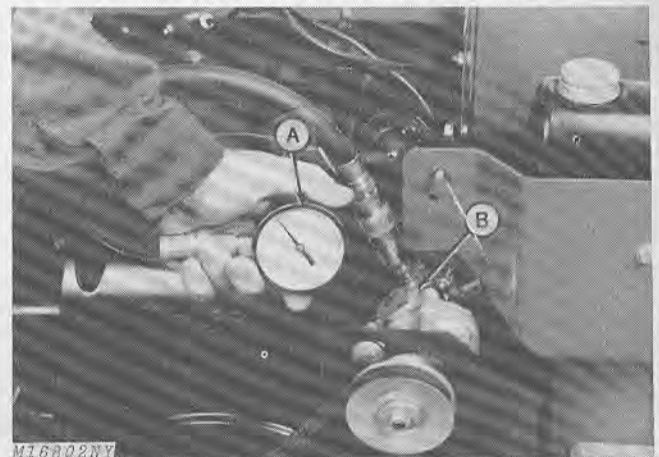

A—Pressure Gauge

B—Pump Outlet

Fig. 3-Testing Pressure at Pump Outlet

A pressure gauge (A) is attached directly to the outlet side of the hydraulic pump (B) to check pump output. Pump output pressure should be 500 to 600 psi.

IMPORTANT: Do not maintain relief valve pressure longer than 2 minutes. Sustained relief valve pressure causes heat build-up and possible damage to the pump.

If pressure does not reach 500 psi, check these possible causes:

Cause	Remedy
Drive belt loose.	Adjust for 1/2-inch deflection
Low oil supply.	Add oil.
Air leak in inlet line.	Check for leaks.
Partially blocked inlet line	Check for obstruction and clean
Defective relief valve.	Replace relief valve.
Contaminated oil.	Change oil.
Worn pump.	Repair pump.

Other hydraulic malfunctions are diagnosed on the next page.

DIAGNOSING MALFUNCTIONS

Problem	Cause	Remedy
Noisy pump (caused by cavitation)	Fluid low in reservoir. Improper viscosity oil. Plugged or kinked inlet line to pump. Plugged outlet on reservoir.	Fill reservoir. Change oil. Straighten and/or clean inlet line. Clean reservoir.
System gets hot.	Fluid low in reservoir. Contaminated oil. Relief valve set too high. Improper oil. Hose restricted (crimped or pinched). Leaks.	Fill reservoir. Change oil. Replace relief valve. Change oil. Straighten hoses. Check fittings, lines and hoses.
Foaming oil.	Improper oil.	Change oil.
Low system pressure.	Fluid low in reservoir. Loose, worn or damaged belt. Loose drive sheave (key missing). Weak relief valve. Worn pump.	Fill reservoir. Replace or adjust belt. Replace key. Replace relief valve. Repair pump
External leakage.	Loose screws. Damaged O-rings. Damaged hoses or loose connections. Valve spool worn or damaged.	Tighten. Replace O-rings. Check fittings, lines and hoses. Replace control valve.
Work load lowers with spool in slow raise position.	Damaged lift check plunger. Damaged lift check seat in body. Damaged O-rings. Damaged lines or loose connections.	Replace lift check plunger. Replace control valve. Replace O-rings. Check fittings, lines and hoses.
Work load drops with spool in neutral position.	Damaged cylinder packing. Line to cylinder leaking. Internal leakage between spool and valve body.	Replace cylinder. Tighten or replace hose. Replace control valve.
Sticky valve spool.	Misaligned control linkage. Foreign material in spool bore.	Correct alignment. Remove spool. Clean spool and bore.

Group 10 CONTROL VALVE

PRINCIPLE OF OPERATION

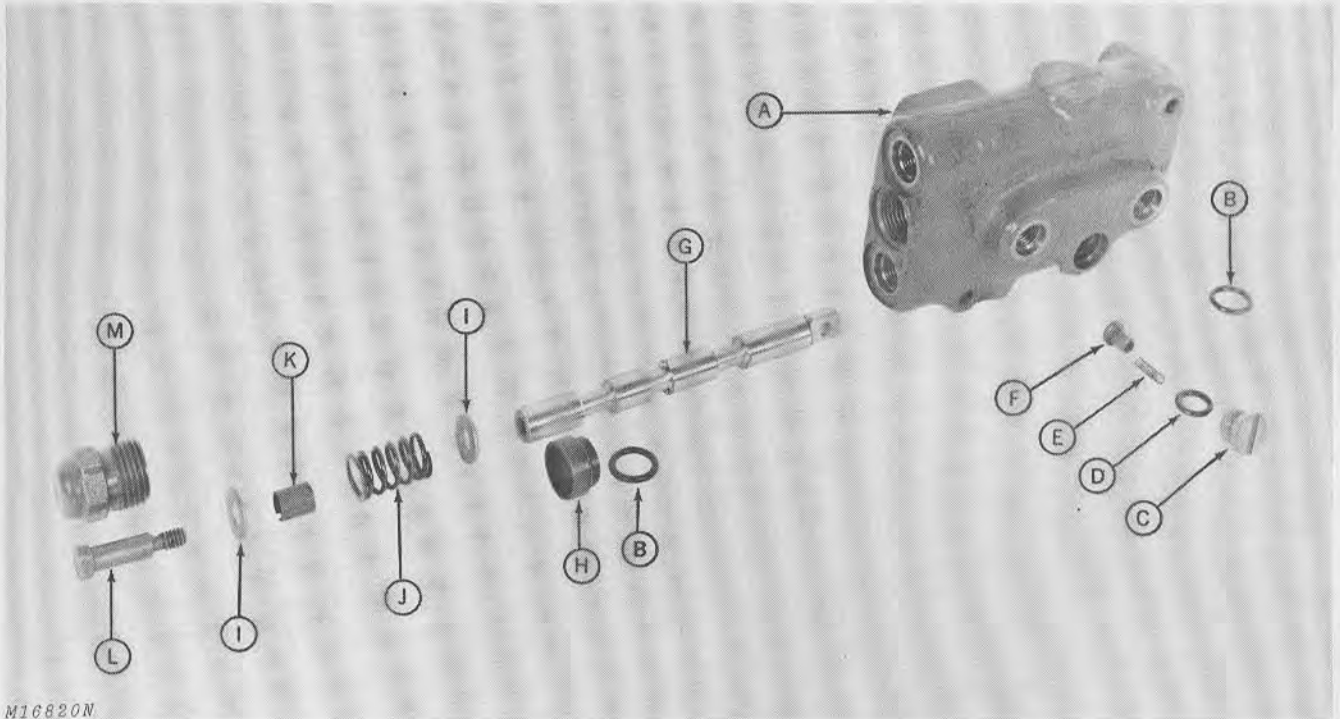

M16820N

- | | |
|----------------------|-------------------|
| A—Valve Body | H—Sleeve |
| B—O-Ring (2 used) | I—Washer (2 used) |
| C—Lift Check Plug | J—Spring |
| D—O-Ring | K—Spacer |
| E—Lift Check Spring | L—Shoulder Bolt |
| F—Lift Check Plunger | M—Cap |
| G—Spool | |

Fig. 1-Control Valve Components

The control valve consists of a valve body, spool, two work ports and a lift check valve. The lift check valve prevents the load or attachment from lowering when lifted from a partially raised position. The control valve is an open center design, in that with the lift lever in neutral position and the engine running, oil flows continuously from the reservoir to the pump through the control valve and back to the reservoir. Oil from the work ports to the cylinder is trapped, locking the cylinder in position.

Before removing and disassembling the control valve, be sure to check "Diagnosing Malfunctions," page 60-5-4, for all possible causes of difficulty.

REMOVAL



Fig. 2-Relieving System Pressure

Lower equipment to the ground. With the engine stopped, move the control lever forward and back to relieve all pressure in the system.

Remove the battery and battery box.

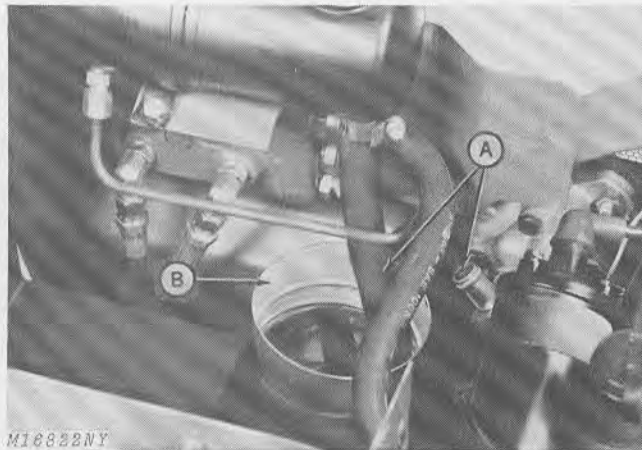

A—Hose

B—Can

Fig. 3-Draining Oil from Reservoir

Wipe all hoses and connections clean. Disconnect hose (A) from reservoir to pump. Drain oil into can (B), Fig. 3.

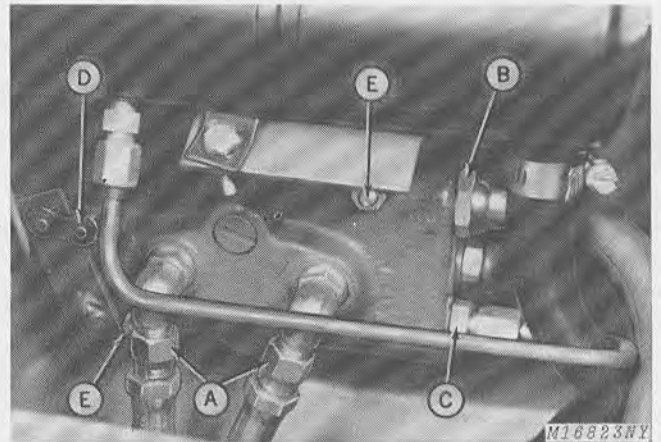

A—Hoses to Cylinder
B—Hose from Pump

C—Line from Reservoir
D—Link
E—Mounting Bolts

Fig. 4-Removing Control Valve

Disconnect hoses to cylinder (A). Disconnect hose from pump (B).

Remove the two bolts and nuts holding the left-hand pedestal side. Remove the pedestal side with reservoir and valve.

Disconnect link (D) between lift lever arm and control valve.

Disconnect line from reservoir at valve (C).

Remove mounting bolts (E) from the control valve and remove valve from side pedestal.

Plug hydraulic lines and hoses to prevent dirt from entering.

DISASSEMBLY

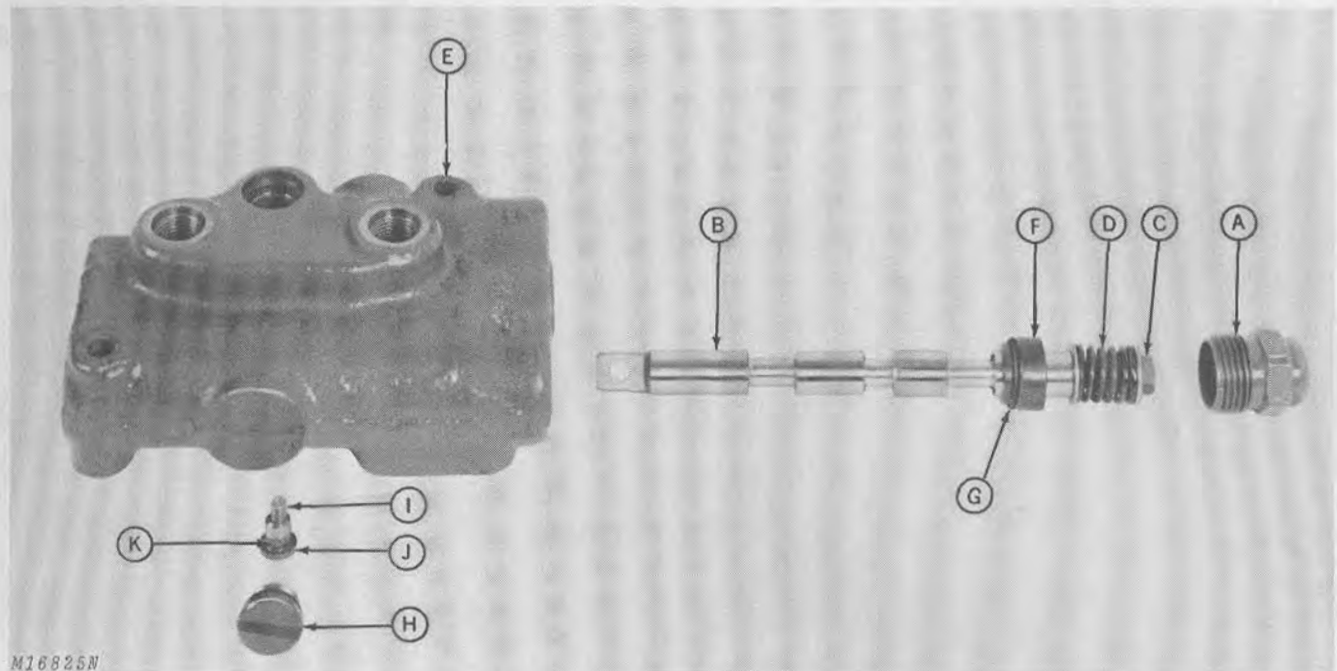

A—Spool Cap
B—Spool
C—Cap Screw

D—Spring
E—Valve Body
F—Sleeve

G—O-Ring
H—Lift Check Plug
I—Lift Check Spring

J—Plunger
K—O-Ring

Fig. 5-Removing Spool and Lift Check Plug

Plug all ports and clean outside of valve thoroughly.

Remove the spool cap (A) and spool (B). Do not remove the cap screw (C) unless the spring (D) needs to be replaced. The spring need not be replaced unless it is broken.

Remove the spool (B) from the valve body (E).

NOTE: Spool (B) and valve body (E) are matched sets. If one is damaged, both must be replaced.

Remove the sleeve (F) and O-ring (G) from the spool (B).

Remove lift check plug (H), spring (I) and plunger (J) from the valve body. Remove the O-ring (K) from the plug (H).

Remove O-ring from control valve body, Fig. 6, using a small wire or paper clip. Discard all O-rings.

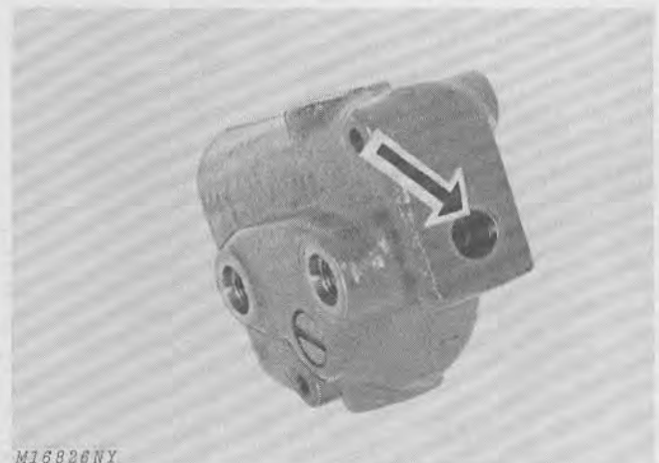

Fig. 6-Removing O-Ring from Valve Body

INSPECTION

Remove all nicks and burrs from ports and inspect the spool (B) and valve body (E) for excessive wear, Fig. 5.

Inspect the spool spring (D) and lift check spring (I) for breakage, Fig. 5.

Do not inspect O-rings. Replace them.

ASSEMBLY

Thoroughly clean and dry all parts. Metal parts should be lightly oiled prior to assembly.

NOTE: Install all new O-rings.

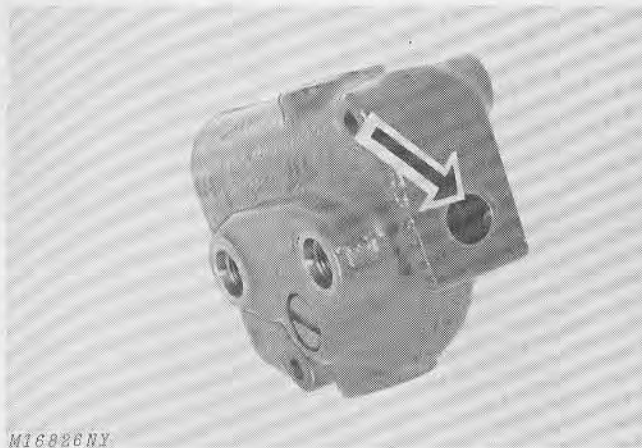

Fig. 7-Installing O-Ring in Valve Body

Position new O-ring in spool bore.

Refer to Fig. 8 and install O-ring (K) on lift check plunger (J). Position spring (I) on plunger (J) and place in valve body (E). Install plug (H).

If spring (D) on spool (B) was removed for replacement, cap screw (C) should be installed with Loctite and tightened to 5 to 8 ft-lbs torque (6.8 to 10.8 Nm).

Slide spool sleeve (F) over spool (B). Place O-ring (G) over spool and position it on sleeve (F). Dip spool in clean oil and insert spool and spring assembly into valve body.

Install the spool cap (A) to secure spool assembly in valve.

Reverse the removal procedure, page 60-10-2, to install the control valve in the tractor.

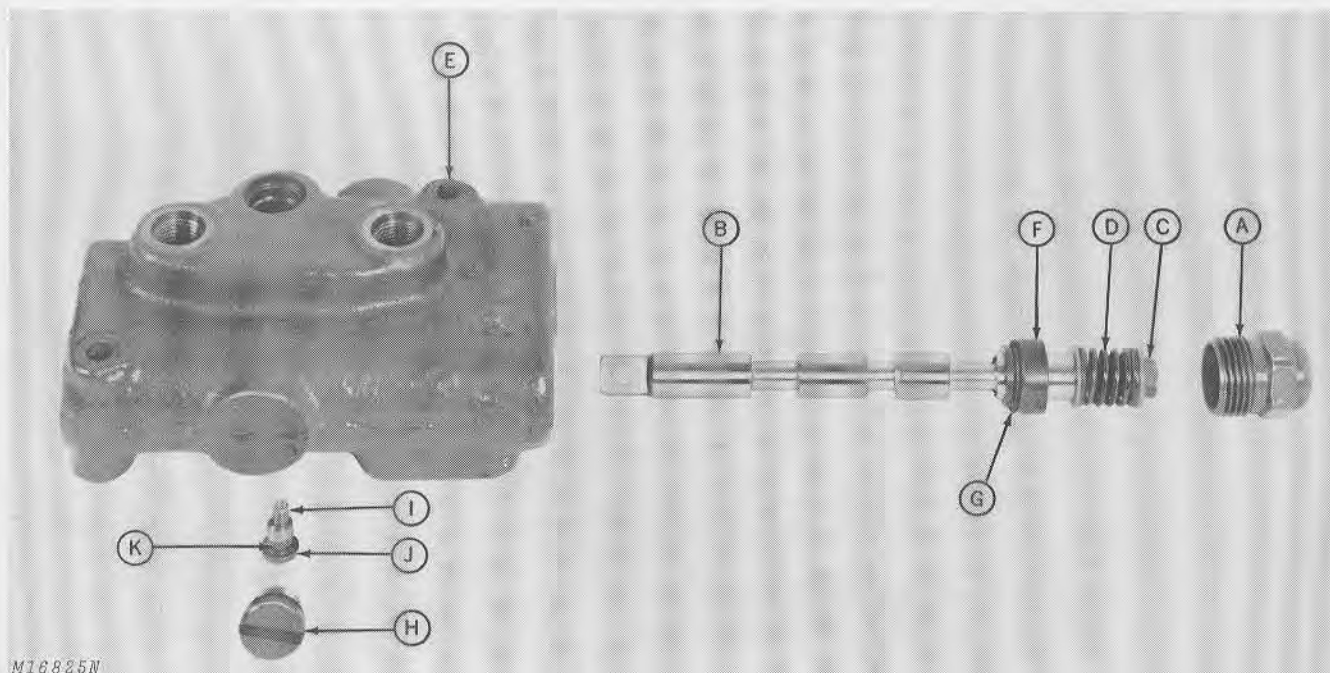

A—Spool Cap
 B—Spool
 C—Cap Screw

D—Spring
 E—Valve Body
 F—Sleeve

G—O-Ring
 H—Lift Check Plug
 I—Lift Check Spring

J—Lift Check Plunger
 K—O-Ring

Fig. 8-Assembling Control Valve

Group 15 PUMP

PRINCIPLE OF OPERATION

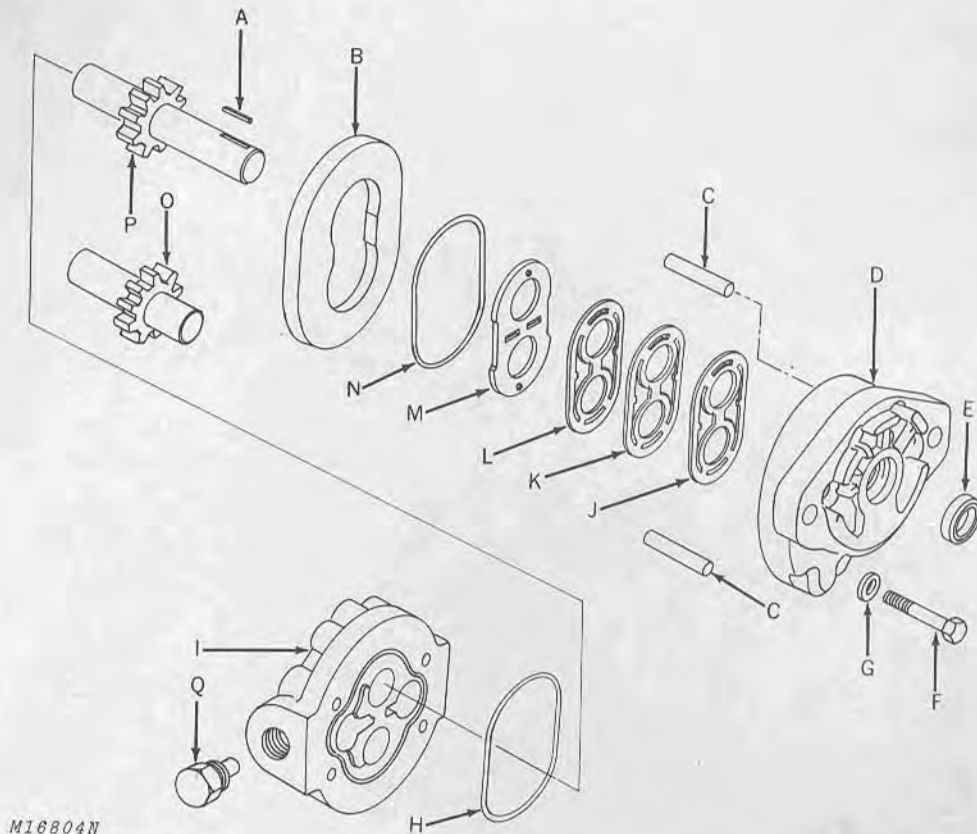

M16804N

- | | | | |
|------------------|-------------|---------------|----------------|
| A—Key | E—Seal | I —Back Cover | M—Wear Plate |
| B—Center Section | F—Cap Screw | J—V-Seal | N—O-Ring |
| C—Dowel Pin | G—Washer | K—Gasket | O—Driven Gear |
| D—Front Cover | H—O-Ring | L—Heat Shield | P—Drive Gear |
| | | | Q—Relief Valve |

Fig. 1-Pump Components

When the pump is in operation, the pump drive gear (P) rotates the driven gear (O). Oil enters the inlet port from the reservoir and is trapped between the gear teeth and the pump housing. As the gears rotate, the oil is displaced and forced out the outlet port of the pump. The volume of oil the pump delivers is dependent upon the speed the pump is driven. The pressure in the system is determined by the relief valve setting and the load applied to the system. When the load is too great, the relief valve will open and channel excess oil to the inlet side of the pump and recycle the oil through the pump.

Gear end clearance is kept at a minimum by means of a bronze-faced steel wear plate (M). The wear plate is kept in contact with the gear ends by hydraulic pressure from the outlet side of the pump. Hydraulic oil is forced through a small hole in the wear plate to the underside of the V-seal (J). This oil pressure pushes the wear plate (M) against the gears, greatly increasing pump efficiency.

REMOVAL

Remove battery and battery box.

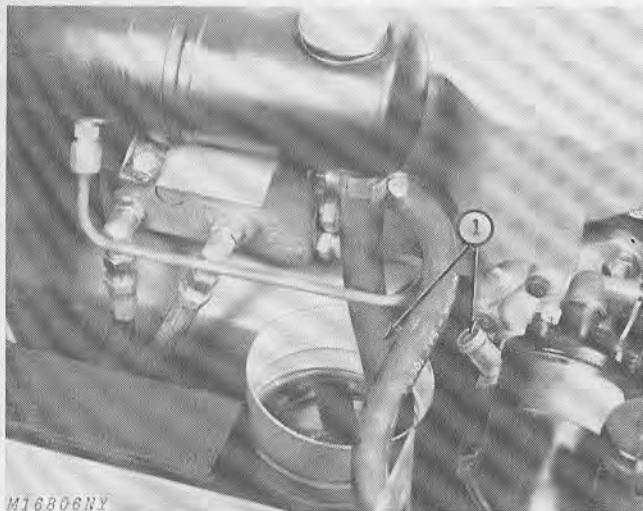

Fig. 2-Draining Hydraulic Oil

1. Disconnect inlet line from pump and drain oil from reservoir into a container.

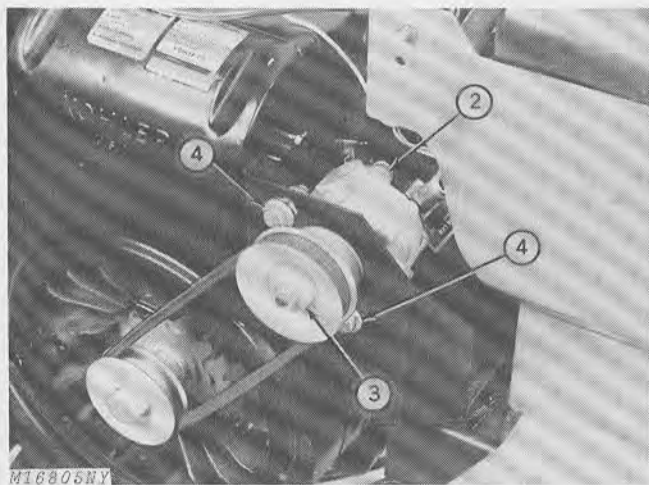

Fig. 3-Removing Pump

2. Disconnect outlet line from pump.

NOTE: Plug hydraulic lines to keep out dirt.

3. Loosen pump mounting cap screws to loosen drive belt. Remove pump drive sheave. Remove key. Do not lose key.

4. Remove pump mounting cap screws, nuts and lock washers and remove pump.

DISASSEMBLY

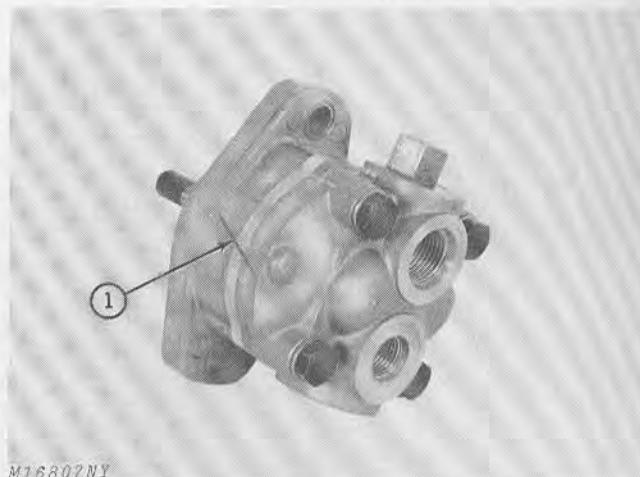

Fig. 4-Disassembling Pump

Clean the exterior of the pump thoroughly with solvent.

1. Scribe a line across the three sections of the pump as a guide for reassembly.

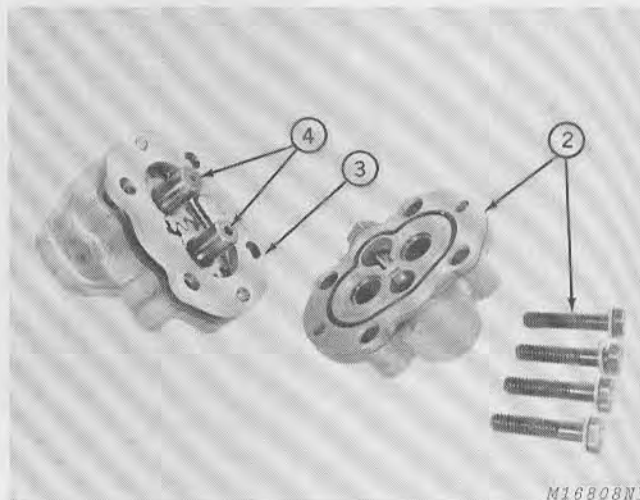

Fig. 5-Disassembling Pump

2. Remove the four cap screws and the front cover. The center section will remain attached to either the front or back cover.

3. Place the drive gear into the unseparated sections; then, remove the center section being careful to avoid cocking it on the dowel pins.

4. Remove the gears.

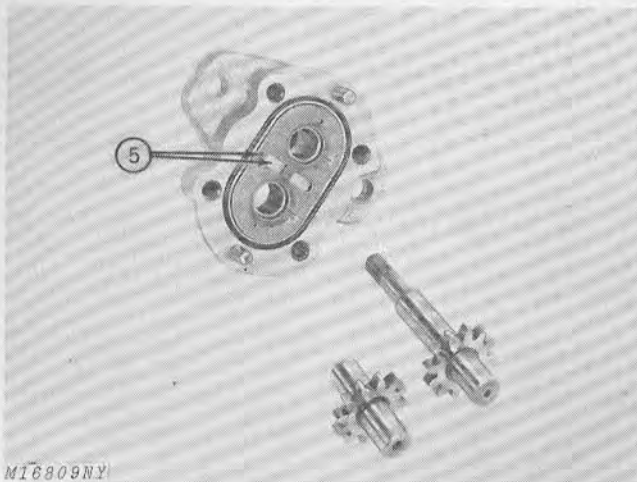

Fig. 6-Marking Pump for Assembly

5. Mark the front cover island next to the pressure vent hole in the wear plate to act as a guide for reassembly. The location of this vent hole determines pump rotation.

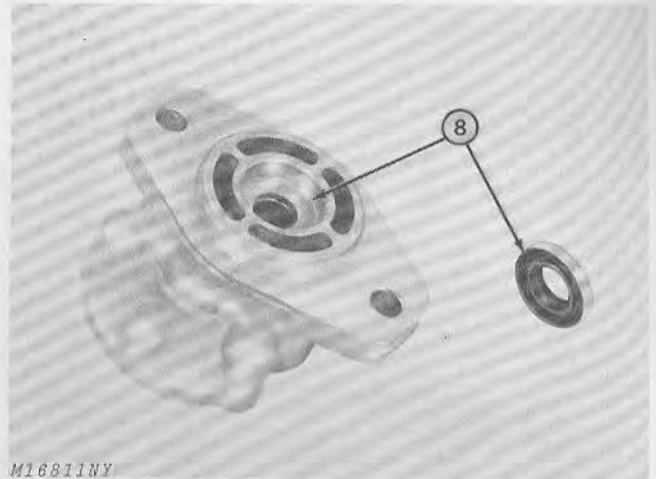

Fig. 8-Removing Shaft Seal

8. Do not remove shaft seal in front cover unless it is damaged or leaking. If the seal is to be replaced be careful not to damage the seal recess, Fig. 8. Heat the cover in an oven to 250°F to reduce the press fit.

9. If the relief valve is defective, replace it as a complete unit, Fig. 7.

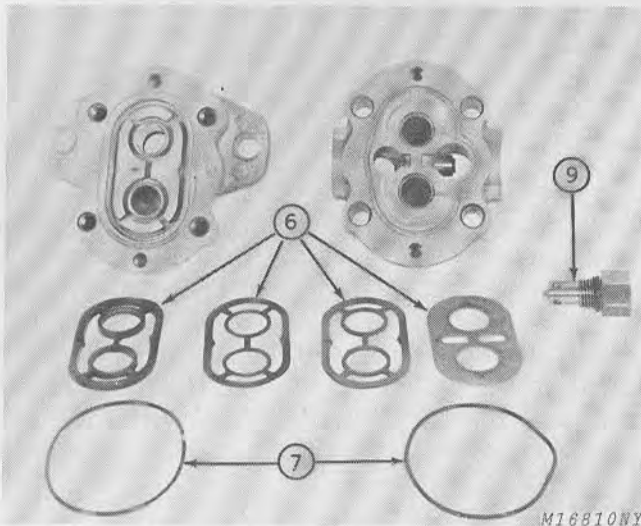

Fig. 7-Pump Disassembly

6. Use a small diameter wire (a paper clip will do) to remove the wear plate, heat shield, gasket and V-seal. Discard these parts. Wear plate wear ridges of more than 0.0005 inch (0.0127 mm) indicates a worn pump in need of repair.

7. Remove and discard both O-rings.

INSPECTION

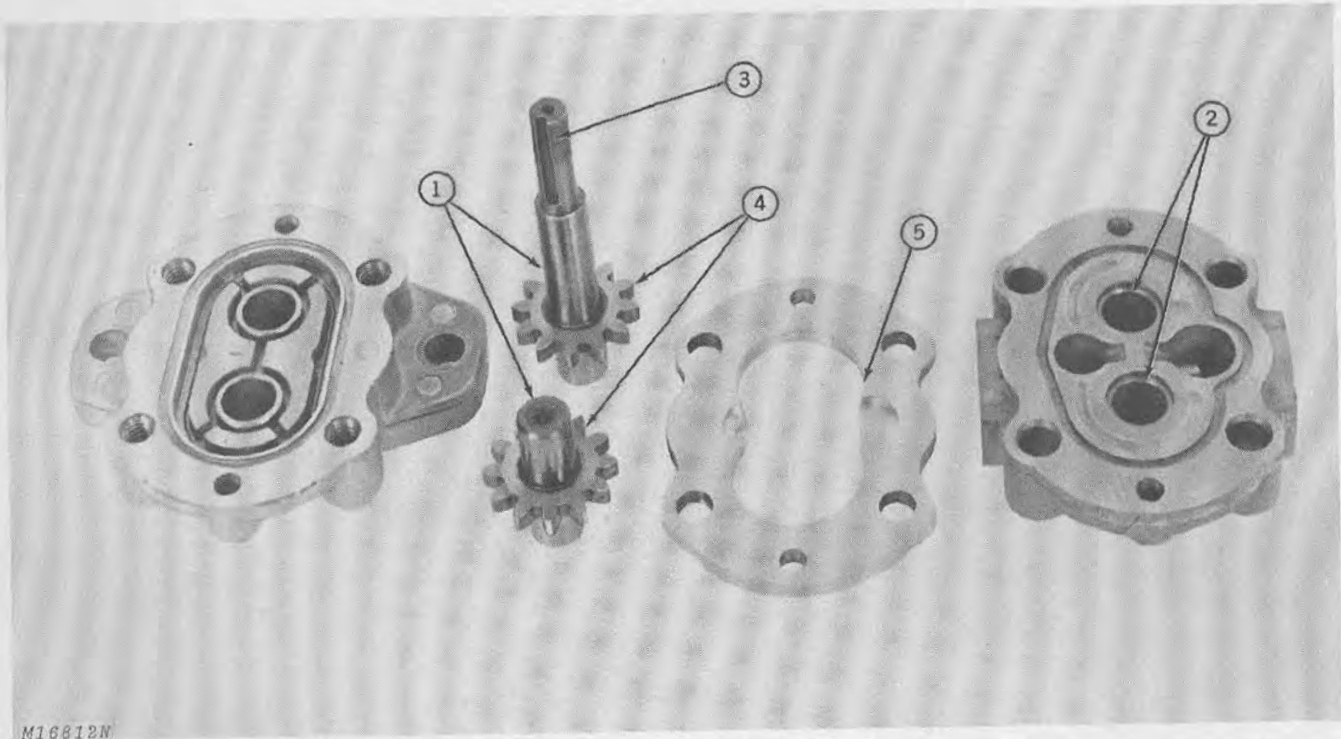

Fig. 9-Inspecting Parts for Wear

1. Inspect shafts for roughness in bearing and sealing areas. Minimum shaft diameter is 0.4998 inch (12.6949 mm).

2. Inspect bearing bore for wear. Maximum bore diameter should not exceed 0.5015 inch (12.7381 mm).

3. Inspect keyway and key for damage or excessive wear.

4. Inspect gear end faces, outside diameter and teeth for roughness and score marks. Minimum gear width is 0.2770 inch (7.0358 mm). Minimum gear outside diameter is 1.2395 inch (31.4833 mm).

5. Inspect the pump center section at the wall of gear bore diameters for excessive wear or score marks. The center section will show wear at the inlet side of the pump. This wear ridge should not exceed 1/32 inch (0.79 mm).

ASSEMBLY

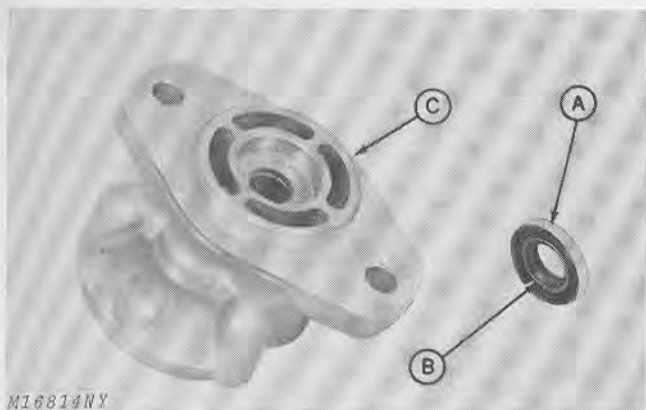

A—Shaft Seal
B—Spring-Loaded Lip
C—Front Cover

Fig. 10-Replacing Shaft Seal

Clean all parts thoroughly before assembly.

If it was removed, install shaft seal (A) into front cover (C) with spring-loaded lip (B) facing inward. Place the front cover (C) on a smooth, flat surface. Use a flat steel rod slightly smaller in diameter than the outside diameter of the seal to force the seal (A) into the front cover (C).

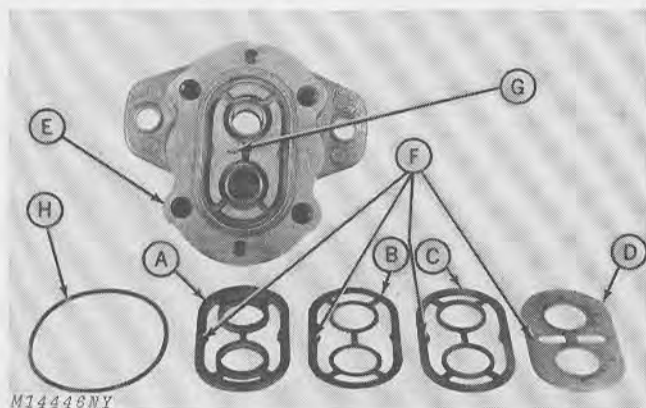

A—V-Seal
B—Gasket
C—Heat Shield
D—Wear Plate
E—Front Cover
F—Vent Holes
G—Scribe Mark
H—O-Ring

Fig. 11-Installing V-Seal, Gasket
Heat Shield and Wear Plate

In this order, install the V-seal (A), gasket (B), heat shield (C) and wear plate (D) into the front cover (E) as follows:

The small vent hole (F) through all these parts must be in line and positioned next to the scribe mark (G) made during disassembly. This locates the vent holes on the outlet side of the pump.

The lips of the V-seal (A) must face toward the cavity. Use a small, dull screwdriver or similar tool to carefully tuck the seal into the groove.

Press the gasket (B) and heat shield (C) firmly toward the bottom of the cavity with your thumbs to provide sufficient space for the wear plate (D).

Install the wear plate (D) with the bronze surface up (toward the gears) and the small vent hole (F) in line with the vent hole in the heat shield.

Install O-ring (H) into front cover (E). If necessary, oil and stretch O-ring slightly so it will remain in its groove.

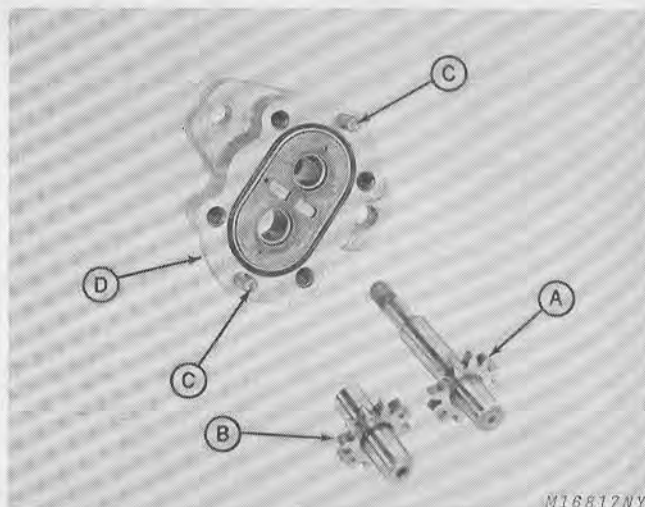

A—Drive Gear
B—Driven Gear
C—Dowel Pins
D—Front Cover

Fig. 12-Installing Gears

Install drive gear (A) and driven gear (B) into the front cover (D). Apply oil to the shaft at the drive end to prevent damage to the shaft seal. Make sure that the shaft seal lip and spring is not pushed out by the shaft.

Install dowel pins (C) into front cover (D).

ASSEMBLY—Continued

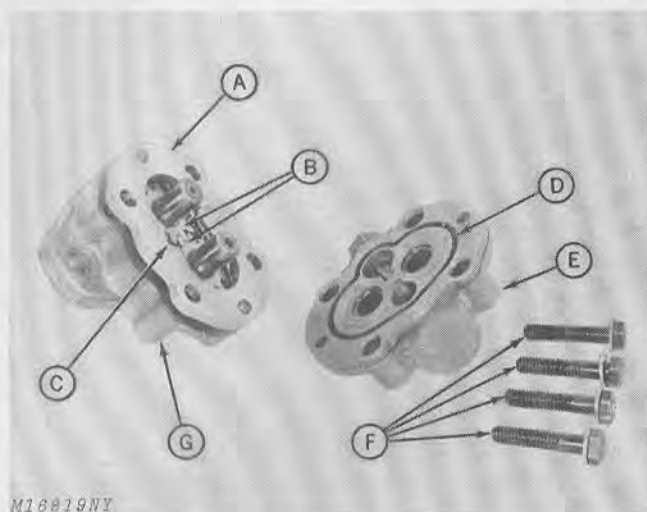

- M16819NY
- A—Center Section
 - B—Gears
 - C—Slot
 - D—O-Ring
 - E—Back Cover
 - F—Cap Screws
 - G—Front Cover

Fig. 13—Installing Center Section and Back Cover

Make sure the wear plate is still seated in its cavity.

Align the scribe mark on the outside of the center section (A) with the scribe mark on the front cover (G) and install the center section (A) over the gears (B). Also, the small slot (C) must align with the small vent hole in the wear plate.

Add a generous amount of oil into the gear cavities. Rotate the gears to distribute the oil.

Install the O-ring (D) in the back cover (E).

Oil the face of the back cover (E).

Align the scribe mark on the back cover (E) with the scribe marks on the center section (A) and front cover (G).

Install the back cover (E) with the four cap screws and washers (F). Tighten the cap screws to 190 to 210 in-lbs (21.467-23.726 Nm) torque.

Add a generous amount of oil to both pump ports to insure adequate lubrication.

Install the pump in the tractor opposite the sequence illustrated on page 60-15-2.

SPECIFICATIONS

Pump Output and Relief Valve Setting	Maximum 4 gallons-per-minute Maximum 500 to 600 pounds-per-square-inch
Wear Tolerances	
Gear Shaft Diameter	Minimum 0.4998 inch (12.6949 mm)
Bearing Bore	Maximum 0.5015 inch (12.6949 mm)
Gear Width	Minimum 0.2770 inch (7.0358 mm)
Gear Outside Diameter	Minimum 1.2395 inch (31.4833 mm)
Center Section Wear Ridge	Maximum 1/32 inch (0.79 mm)
Wear Plate Wear Ridge	Maximum 0.0005 inch (0.0127 mm)
Cap Screw Torque	190 to 210 in-lbs (21.467 to 23.726 Nm)

Group 20 CYLINDER

PRINCIPLE OF OPERATION

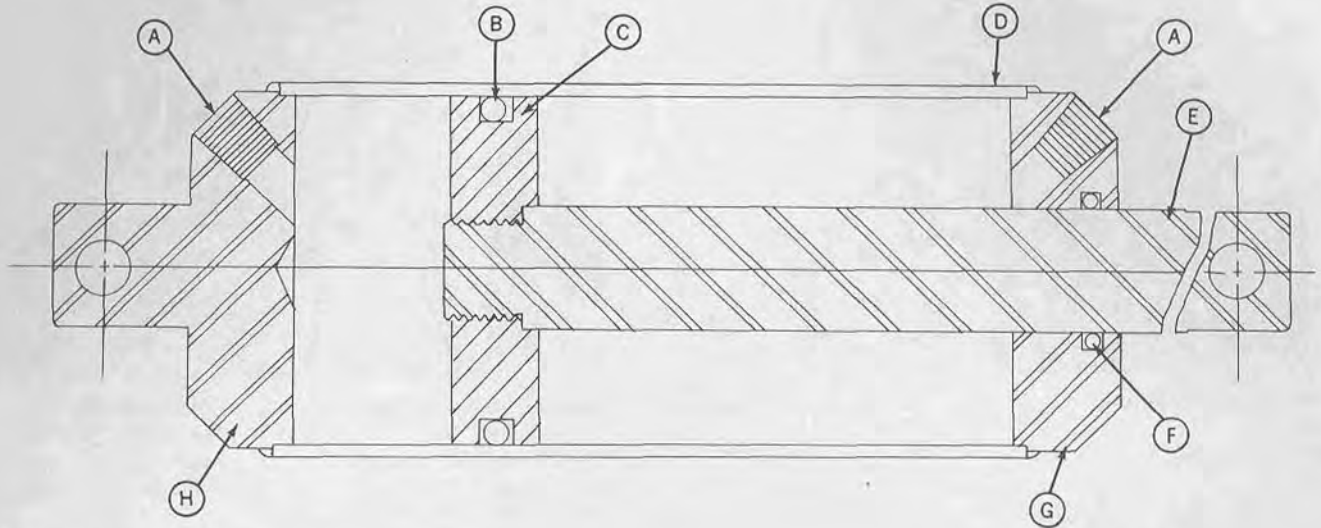

M16829N

A—Oil Port
B—O-Ring
C—Piston
D—Barrel

E—Piston Rod
F—O-Ring
G—Bearing
H—Head

Fig. 1-Cutaway View of Double-Acting Cylinder

The Cessna cylinder is mounted on the underside of the tractor to a pin in the frame and to the lift quadrant. When the hydraulic lift lever is moved forward or back, the lift cylinder is extended or retracted, thus actuating the lift linkage and raising or lowering mounted equipment.

The cylinder is double-acting and connected to the valve body by two high-pressure flexible hoses. Although the hydraulic cylinder is double-acting, slots in the linkage prevent the retracting cylinder from exerting downward forces on front or rear-mounted equipment. This prevents damage to the equipment and allows it to float with ground contours.

The hydraulic cylinder is a welded assembly and is not servicable. A new cylinder must be installed if the old cylinder is defective.

Remove and replace the cylinder as shown on the next page.

REMOVAL

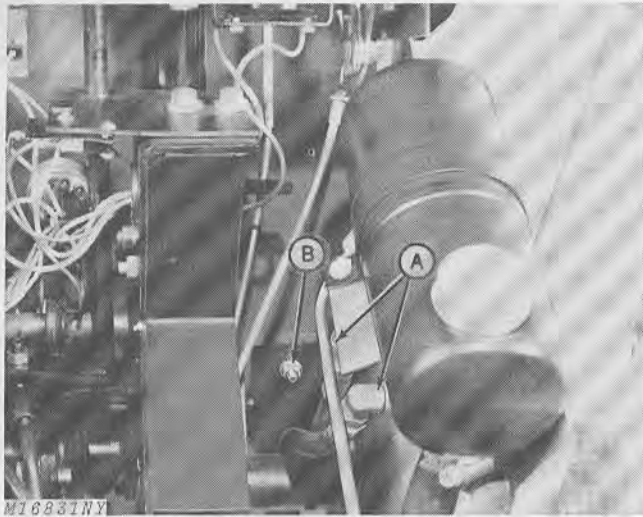

A—Hydraulic Cylinder Hoses **B—Hose Guide Nut**

Fig. 2-Battery and Battery Box Removed for Access

(Not illustrated.) Lower attachment to the ground.

(Not illustrated.) With the engine shut off, move the hydraulic control lever back and forth to relieve all pressure in the system.

(Not illustrated.) Remove the battery and battery box to provide access.

Disconnect the hydraulic cylinder hoses (A) from the control valve, Fig. 2. Plug the ends of the hoses to keep out dirt.

Loosen the hose guide nut (B) and pull the hoses down below the frame.

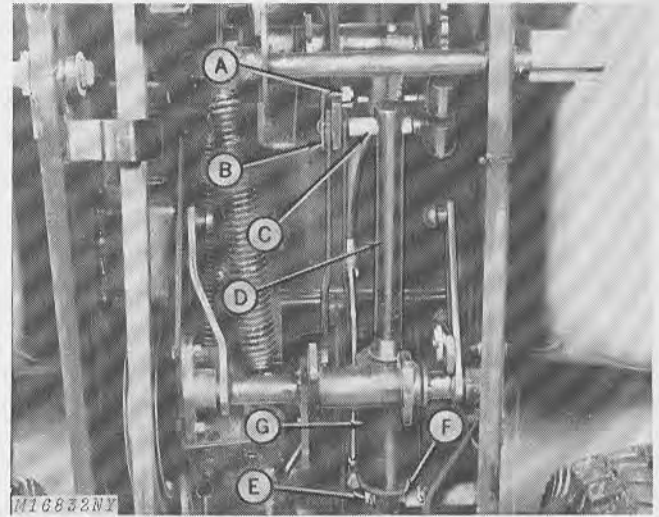

A—Cap Screw, Flat Washer and Hex. Nut **E—Cotter Pin and Flat Washer**
B—Offset Strap and Pin **F—Pivot Pin**
C—Spacer **G—Cylinder**
D—Lift Cylinder Ram

Fig. 3-Removing Hydraulic Lift Cylinder

Remove the cap screw, flat washer and hex. nut (A) holding the offset strap and pin, Fig. 3.

Remove the offset strap and pin (B), Fig. 3.

Remove the spacer (C) from the end of the lift cylinder ram (D), Fig. 3.

Remove the cotter pin and flat washer (E) from the pivot pin, Fig. 3. Slide the rear part of the cylinder (G) off the pivot pin (F). Remove the cylinder (G) with hoses.

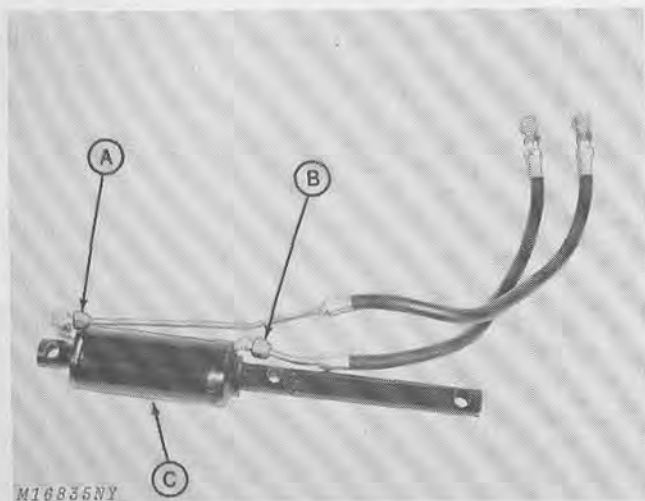

A—Longer Hose and Line B—Shorter Hose and Line
C—Cylinder

Fig. 4-Hydraulic Cylinder Hoses

Disconnect hose lines (A and B) from cylinder (C), Fig. 4. Remove fittings and discard defective cylinder.

INSTALLATION

Install the fittings in the new cylinder and connect the longer hose and line (A), Fig. 4, to the cylinder rear port. Connect the shorter hose and line (B) to the cylinder front port.

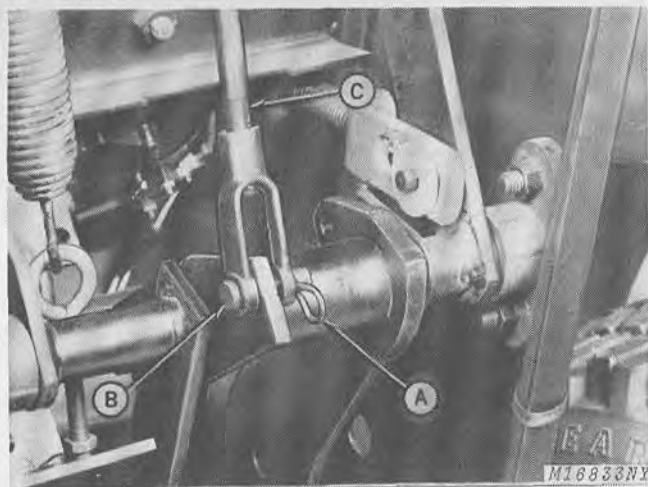

A—Spring Locking Pin B—Drilled Pin
C—Lift Link

Fig. 5-Disconnecting Lift Link

Pull the spring locking pin (A) and remove the drilled pin (B) to disconnect the lift link (C), Fig. 5.

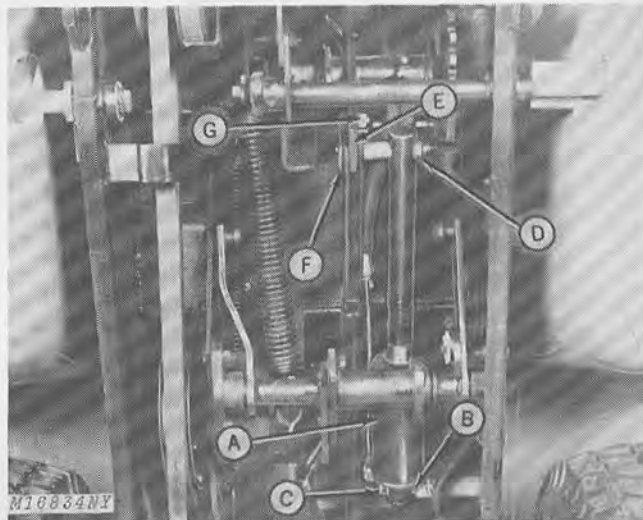

A—Cylinder D—Spacer
B—Pivot Pin E—Primary Lift Arm
C—Flat Washer and F—Offset Strap and Pin
Cotter Pin G—Cap Screw, Flat
Washer and Hex. Nut

Fig. 6-Installing Hydraulic Lift Cylinder

Position cylinder (A) and hoses in tractor. Slide rear of cylinder (A) on pivot pin (B). Secure cylinder (A) to pivot pin (B) with a flat washer and cotter pin (C), Fig. 6.

Slide spacer (D) through hole in cylinder ram, Fig. 6.

Manually rotate primary lift arm (E) rearward.

NOTE: Remove plugs from ends of hoses. The cylinder ram can then be moved in and out to make installing the cylinder easier. However, be sure to keep dirt from entering hoses.

Attach ram to quadrant with offset strap and pin (F) through spacer (D), Fig. 6. Bolt offset strap and pin (F) to primary lift arm (E) with a 5/16 x 7/8-inch cap screw, flat washer and hex. nut (G), Fig. 6.

Refer to Fig. 5 and connect lift link (C) with drilled pin (B) and spring locking pin (A).

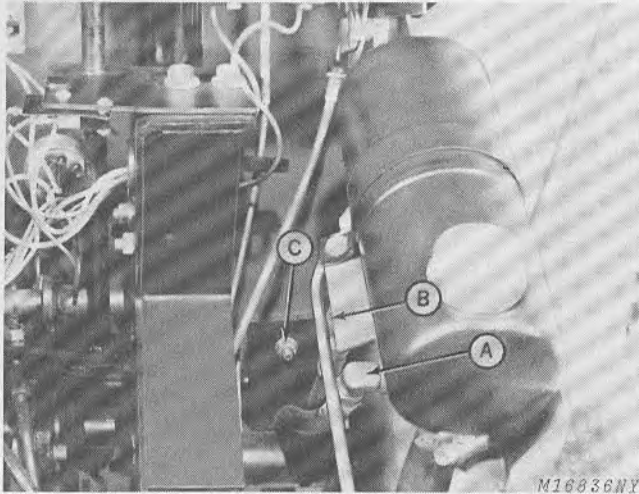

- A—Hose from Rear Cylinder Port
- B—Hose from Front Cylinder Port
- C—Hose Guide Nut

Fig. 7-Connecting Hoses to Control Valve

Connect the hose from the cylinder rear port to the control valve front port (A), Fig. 7.

Connect the hose from the cylinder front port to the control valve rear port (B), Fig. 7.

Position hoses in hose guide slot. Push down on hose guide and tighten nut (C).

IMPORTANT: Make sure hydraulic hoses clear all linkage.

(Not illustrated.) Install battery box and battery.

Section 70

MISCELLANEOUS

Group 5

STEERING LINKAGE

CONTENTS

	Page		Page
Group 5 - Steering Linkage		Group 10 - Front Wheels and Axles	
General Information	5-2	Introduction	10-1
Steering Analysis	5-3	Repair	10-1
Seal and Retainer	5-3	Removing Front Wheels	10-2
Housing	5-3	Removing Spindles from Axle	10-2
Spindle	5-4	Installation	10-2
Ball joints	5-4	Installing Axle	10-2
Diagnosing Malfunctions	5-5	Installing Spindles	10-3
Repair	5-6	Installing Bearings and Wheels	10-3
Removing Steering Wheel and Steering Gear	5-6	Group 15 - Lift Linkage	
Disassembling Steering Gear	5-7	General Information	15-1
Inspecting Steering Gear Parts	5-7	Manual Lift	15-1
Assembly	5-7	Connecting Link	15-1
Assembling Steering Gear	5-7	Helper Spring Kit	15-1
Installing Steering Gear	5-8	Depth Control	15-1
Adjustments	5-9	Diagnosing Malfunctions	15-2
Steering Gear	5-9	Group 20 - Attachments	
Adjusting Toe-In	5-10	Preparing Tractor	20-1
Adjusting Steering Linkage	5-10	Adjusting Lift Connecting Link	20-1
Torque for Hardware	5-11	Adjusting Rear Wheel Tread	20-1
		Checking Electric Lift	20-1
		Adjusting Attachment Lift	20-2
		37A Snow Thrower	20-2
		43 Front Blade	20-2
		43 Center Blade	20-3
		39 and 47 Rotary Mowers	20-3
		31 Tiller	20-3
		Trouble Shooting	20-4
		Service Interval Chart	20-5

GENERAL INFORMATION

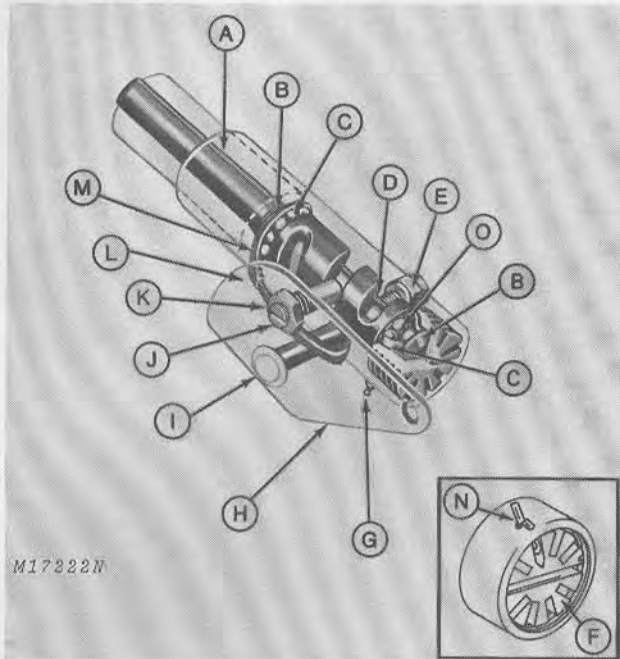

M17222N

- | | |
|------------------|-----------------|
| A—Housing | H—Lever Arm |
| B—Spring Washer | I—Pivot Bolt |
| C—Cup | J—Tapered Stud |
| D—Cam | K—Lock Nut |
| E—Jam Nuts | L—Seal |
| F—Adjusting Plug | M—Seal Retainer |
| G—Grease Fitting | N—Cotter Pin |
| | O—Bearing Balls |

Fig. 1-Ross Steering Gear

The steering linkage consists of the steering gear assembly, drag link, spindles and tie rod.

The steering gear has a 14:1 steering ratio. It is a cam and lever type steering gear, utilizing the cam (D), lever arm (H), pivot bolt (I) and tapered stud (J) shown in Fig. 1.

The lever arm (H) is actuated whenever the cam is rotated. This in turn, pulls or pushes the drag link connected to the left steering spindle, turning the wheels left or right.

The left and right-hand steering spindles are connected by a tie rod (C, Fig. 2) to give equal movement on both spindles.

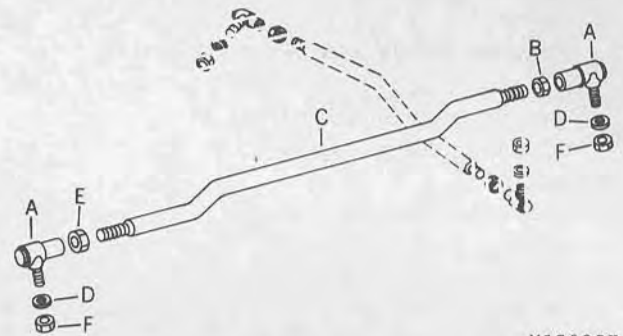

M17223N

- | | |
|----------------------|----------------------|
| A—Ball Joint | D—Lock Washer |
| B—Nut (L.H. Threads) | E—Nut (R.H. Threads) |
| C—Tie Rod | F—Jam Nuts |

Fig. 2-Tie Rod

STEERING ANALYSIS

Listed below are some difficulties that might occur with the steering system. Familiarize yourself with this information before proceeding to "Diagnosing Malfunctions" on page 70-5-5.

Seal and Retainer

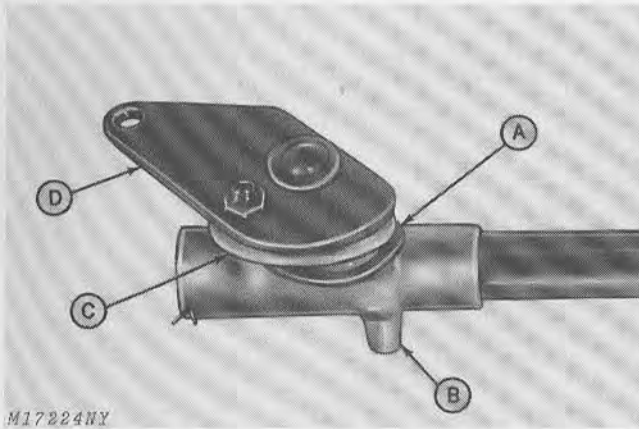

A—Seal
B—Housing
C—Seal Retainer
D—Lever Arm

Fig. 3-Damaged Seal

A damaged seal (A), Fig. 3, is caused by over-greasing the housing (B), or improperly adjusting the cross bolt in the lever arm (D).

Housing

A broken steering gear housing, Fig. 4, is most commonly caused by the wheels striking a solid object when the tractor is traveling at fast speed. It can also be caused by applying excessive pressure on the steering wheel with a heavy load on the front of the tractor.

To reduce steering effort, the tractor should be in motion when turning the front wheels, especially with heavy ballast on the front of the tractor.

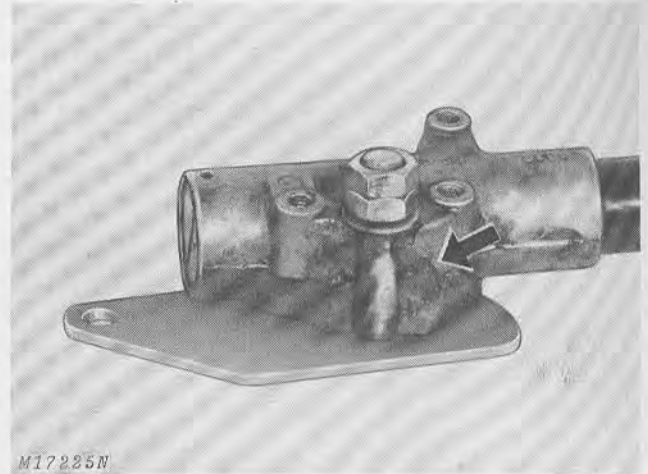

Fig. 4-Broken Steering Gear Housing

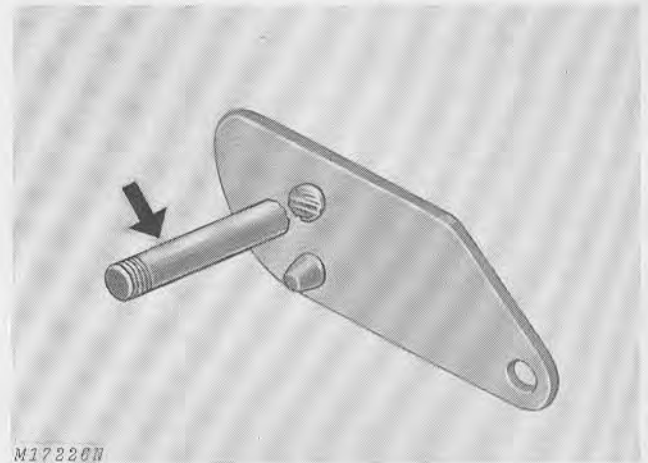

Fig. 5-Broken Lever Arm Cross Bolt

A broken lever arm cross bolt, Fig. 5, is caused by excessive force being applied either by the steering wheel or excessive weight on the front end.

STEERING ANALYSIS—Continued

Spindle

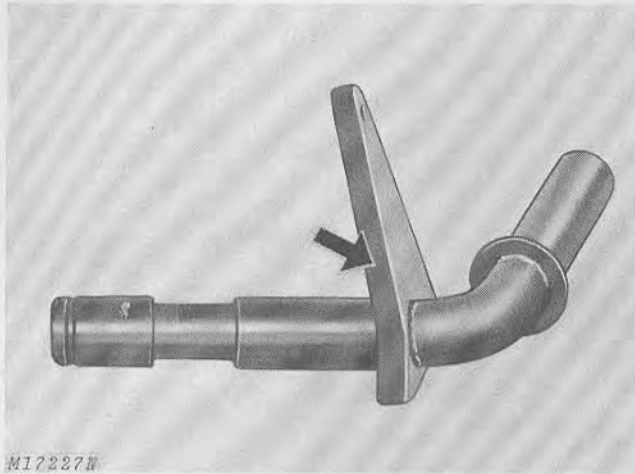
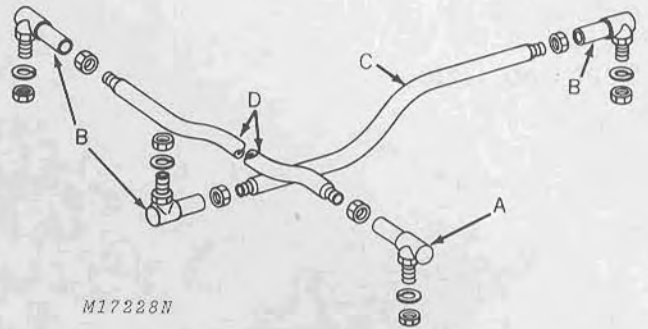

Fig. 6-Bent Spindle Arm

A bent spindle arm, as shown in Fig. 6, is usually the result of the front wheel striking a solid object.

Ball Joints



A—Ball Joints with L.H. Threads
B—Ball Joints with R.H. Threads

C—Drag Link
D—Tie Rod

Fig. 7-Ball Joints

Replace ball joint assembly (A) or (B), Fig. 7, whenever excessive looseness or other damage is noticed.

DIAGNOSING MALFUNCTIONS

Loose Steering

- Steering gear out of adjustment.
- Cracked steering gear housing.
- Loose ball joint nuts.
- Worn ball joints.

Hard Steering

- Tires not properly inflated.
- Steering gear not properly adjusted (too tight).
- Tight spindles.
- Drag link installed incorrectly.
- Bent spindle arm.
- Tight ball joints.
- Incorrect toe-in.

Tractor Turns Shorter in One Direction

- Spindle arm striking axle stop.
- Drag link installed and/or adjusted incorrectly.
- Bent spindle and/or spindle arm.

Leaky Steering Gear Housing

- Damaged seal.
- Damaged retainer.
- Steering gear over-lubricated.

Tire Strikes Tractor on Turns

- Drag link not properly adjusted.
- Bent spindle and/or spindle arm.
- Bent axle.
- Tires not properly inflated.
- Drag link not properly adjusted.

Steering Column Squeaks When Steering Wheel is Turned

- Lack of lubrication.

Excessive End Play

- Loose adjusting plug.

REPAIR

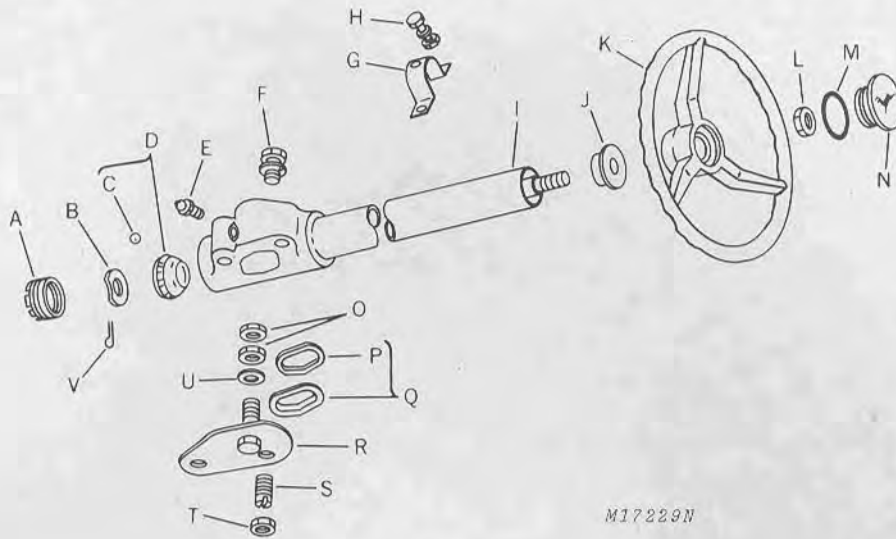

A—Adjusting Plug
B—Spring Washer
C—Ball
D—Bearing Kit
E—Grease Fitting
F—Cap Screw
G—Clamp

H—Cap Screw
I—Steering Gear Assembly
J—Bearing
K—Steering Wheel
L—Jam Nut
M—O-Ring
N—Cap

O—Jam Nut
P—Seal
Q—Seal and Retainer Kit
R—Lever Arm
S—Stud
T—Jam Nut
U—Washer
V—Cotter Pin

Fig. 8—Exploded View - Steering Linkage

Removing Steering Wheel and Steering Gear

Remove steering wheel with a puller (A, Fig. 9).

IMPORTANT: The wrong puller will damage the steering wheel. See page 80-15-2 for correct puller.

Remove battery and battery box.

Remove clamp securing steering column to pedestal.

Disconnect drag link from lever arm.

Remove cap screws holding housing to frame and slip steering gear out from below tractor.

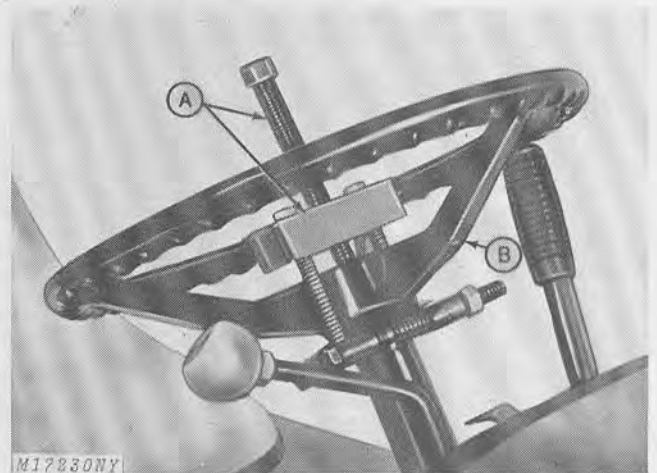

A—Puller

B—Steering Wheel

Fig. 9—Removing Steering Wheel

Disassembling Steering Gear

Loosen jam nut on tapered stud (I) in lever arm (H), Fig. 10.

Turn stud (I) in until resistance is felt.

Remove nuts (B) from lever arm cross bolt (A), and remove cross bolt from housing.

Remove cotter pin (K) and plug (F) in steering gear housing (J) and slide shaft with cam and bearings from column.

Inspecting Steering Gear Parts

Wash parts in clean solvent. Dry them with compressed air and a clean cloth.

Inspect cam, housing, and plug for cracks, scoring, and other damage especially in the bearing area.

Replace parts showing excessive wear or damage.

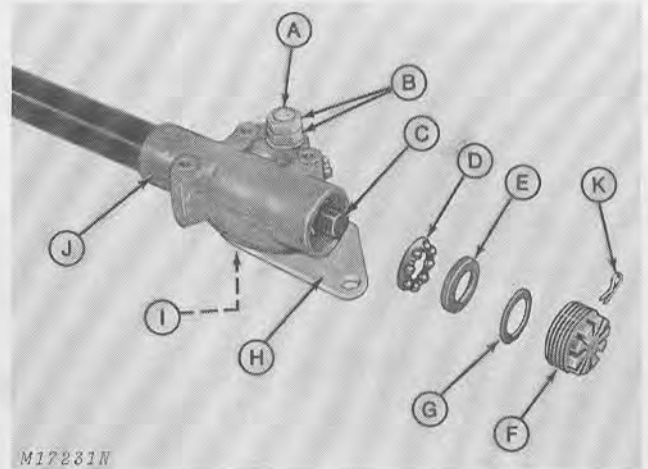

- | | | |
|------------------|------------------|-----------------|
| A—Cross Bolt | D—Bearing | G—Spring Washer |
| B—Lock Nuts | E—Bearing Cup | H—Lever Arm |
| C—Steering Shaft | F—Adjusting Plug | I—Tapered Stud |
| | | J—Housing |
| | | K—Cotter Pin |

Fig. 10-Disassembling Steering Gear

ASSEMBLY

Assembling Steering Gear

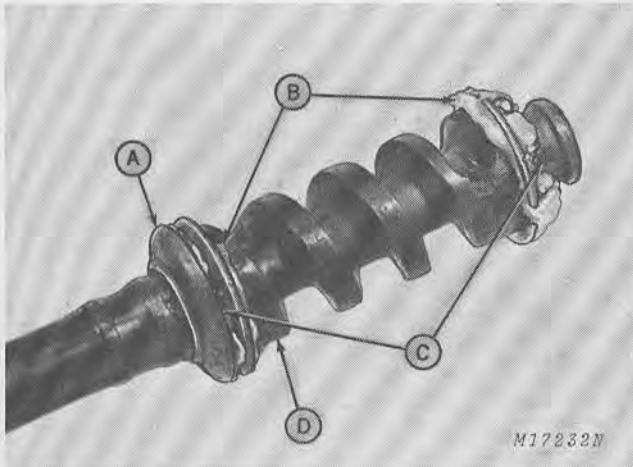

- | | |
|-------------------|-----------------|
| A—Retaining Rings | C—Bearing Balls |
| B—Grease | D—Cam |

Fig. 11-Installing Bearings

Apply grease (John Deere Multipurpose Lubricant or equivalent) and place bearing balls (C), ball cups and retaining rings (A) on both ends of cam (D), Fig. 11.

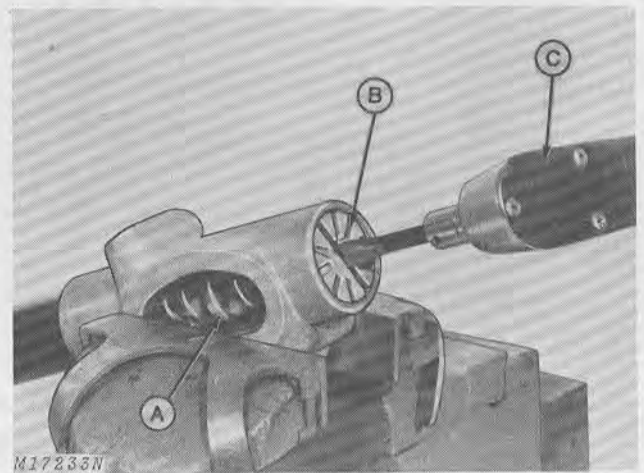

- | | | |
|-------|--------|-----------------|
| A—Cam | B—Plug | C—Torque Wrench |
|-------|--------|-----------------|

Fig. 12-Installing Cam Assembly in Housing

Grease cam (A, Fig. 12) lightly with John Deere Multipurpose Lubricant or an equivalent SAE multi-purpose-type grease.

Slide cam and shaft assembly into housing. Install plug (B, Fig. 12) and tighten to 10 to 14 ft-lbs (13.6 to 17.6 Nm) torque.

Assembling Steering Gear—Continued

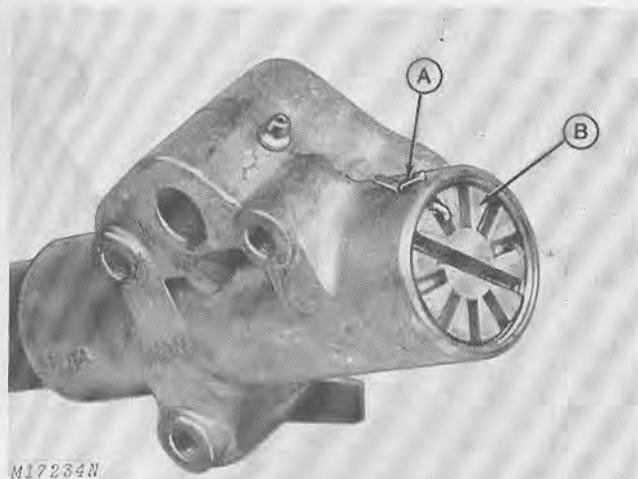

A—Cotter Pin B—Adjusting Plug

Fig. 13-Cotter Pin Through Housing

After tightening adjusting plug (B) torquing to 10 to 14 ft-lbs (13.6 to 17.6 Nm) torque, lock adjusting plug (B) with a cotter pin (A), Fig. 13. Be sure steering shaft turns freely after torquing.

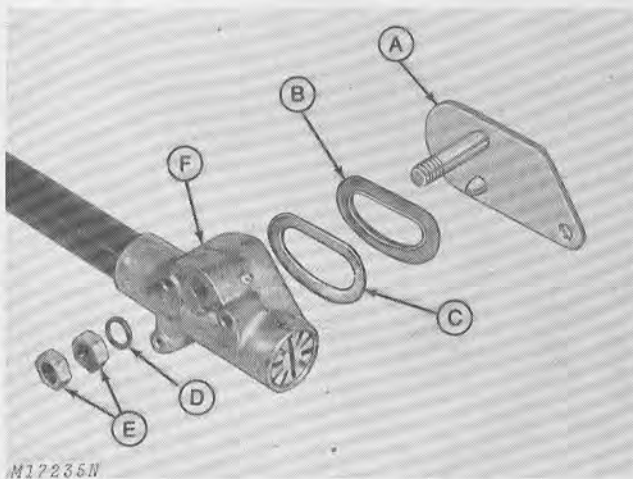

A—Lever Arm B—Retainer
C—Seal D—Washer
E—Jam Nuts F—Housing

Fig. 14-Attaching Lever Arm to Steering Gear

Install new seal (C) and retainer (B) from repair kit. Attach lever arm (A) to steering gear housing (F) with washer (D) and jam nuts (E), Fig. 14.

Installing Steering Gear

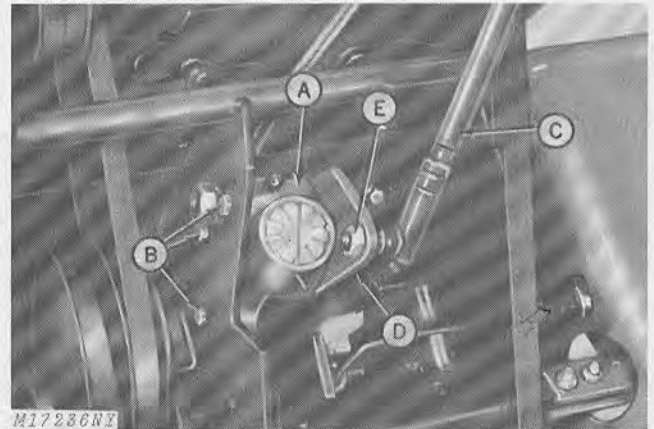

A—Steering Gear Assembly
B—Cap Screws
C—Drag Link
D—Lever Arm
E—Nut

Fig. 15-Installing Steering Gear

Position steering gear assembly (A) in tractor. Install steering gear with cap screws (B) as shown, Fig. 15. Apply Loctite or equivalent to threads of cap screws.

Connect drag link (C) to lever arm (D), Fig. 15, and tighten nut (E) firmly.

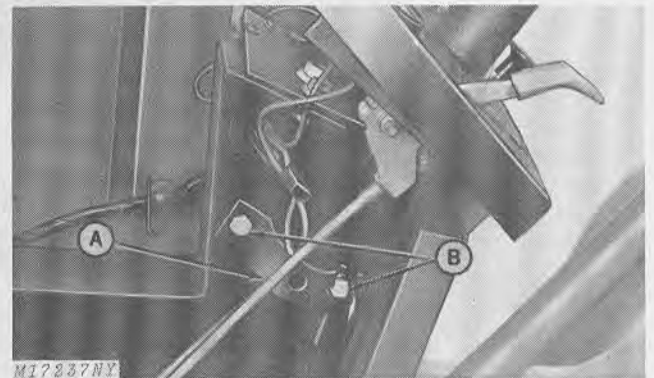

A—Clamp B—Cap Screw

Fig. 16-Installing Steering Column

Place clamp (A) over upper part of steering column inside pedestal. Secure clamp with two cap screws (B) and nuts.

Install steering wheel. Tighten steering wheel retaining nut to 10 to 12 ft-lbs (13.6 to 16.3 Nm) torque.

Insert O-ring into slot in steering wheel cap and press cap into steering wheel.

Adjust the steering gear according to the sequence on page 70-5-9.

ADJUSTMENTS

Steering Gear

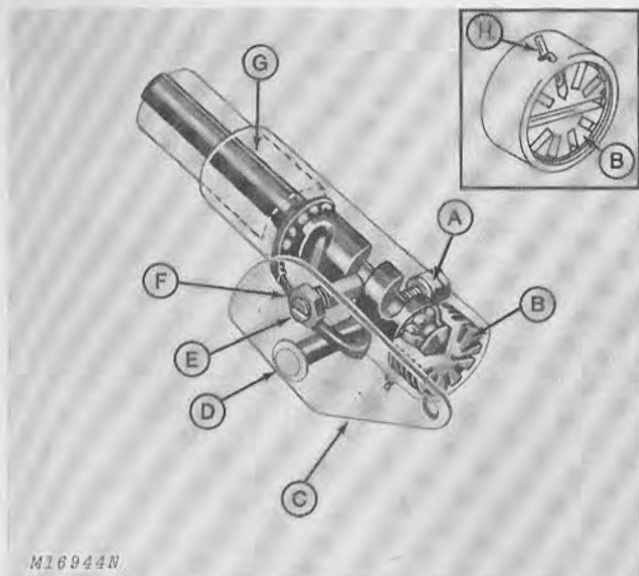

- A—Jam Nuts
B—Adjusting Plug
C—Lever Arm
D—Cross Bolt
E—Tapered Stud
F—Jam Nut
G—Housing
H—Cotter Pin

Fig. 17-Adjusting Bearings

Disconnect drag link (not illustrated) from lever arm (C), Fig. 17.

Loosen jam nuts (A) on cross bolt (D).

Loosen jam nut (F) and tapered stud (E) several turns.

Remove cotter pin (H) from adjusting plug.

Tighten adjusting plug (B) into housing (G) to 10 to 14 ft-lbs (13.6 to 17.6 Nm) torque.

Install cotter pin (H).

Connect drag link to lever arm.

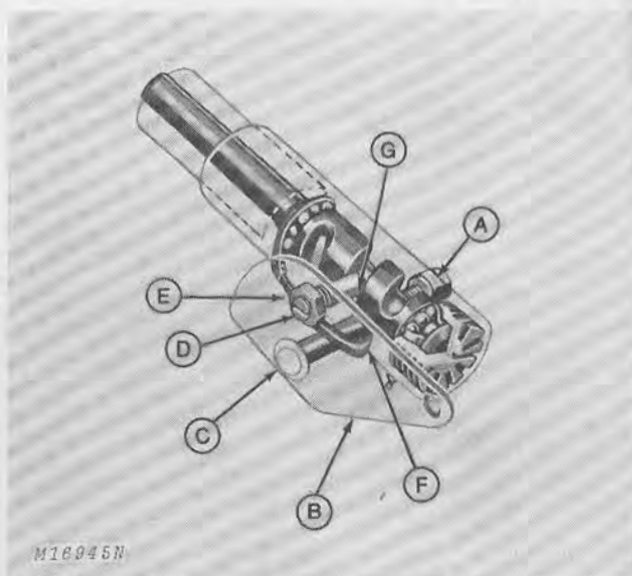

- A—Jam Nuts
B—Lever Arm
C—Cross Bolt
D—Tapered Stud
E—Jam Nut
F—Housing Face
G—Mid-Point on Gear

Fig. 18-Adjusting Backlash

Adjust the steering gear so there is a slight drag at mid-point (G), Fig. 18, as the steering wheel is turned through its full range of travel.

To find mid-point (G), count the number of turns from one extreme to the other.

Turn steering wheel one-half the total number of turns. Adjust at this point.

Loosen tapered stud (D) two or three turns.

To adjust backlash, place a 0.100-inch (2.54 mm) thick spacer between lever arm (B) and housing face (F).

Tighten inside jam nut (A) until spacer is held tight.

Then loosen inside jam nut just enough to remove spacer.

Tighten outside jam nut (A) to 40 ft-lbs (54.23 Nm) torque.

Turn tapered stud (D) into housing until it is snug.

Tighten jam nut (E) to 40 ft-lbs (54.23 Nm) torque.

Turn steering wheel through full range of travel, for final test.

Adjusting Toe-In

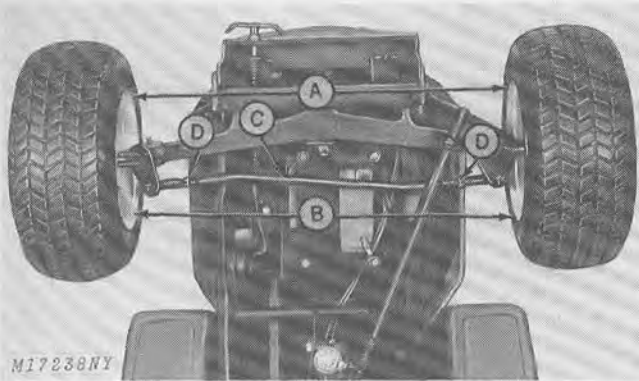

A—Distance at Front
of Wheel
B—Distance at Rear
of Wheel

C—Tie Rod
D—Jam Nuts

Fig. 19-Adjustable Tie Rod Viewed
from Underneath Tractor

Measure distances (A) and (B), Fig. 19. The tractor has proper toe-in or alignment when dimension (A) is 3/16-inch less than dimension (B).

When required, loosen jam nuts (D) and turn tie rod (C) until proper toe-in is obtained. Tighten jam nuts (D) firmly.

Adjusting Steering Linkage

Adjust the steering linkage to obtain the following.

1. Adequate clearance (A) between the drag link (B) and tire (C) as shown, Fig. 20.
2. To provide equal left and right turning radius.
3. To provide maximum clearance between mower deck and drag link when mower deck is raised.

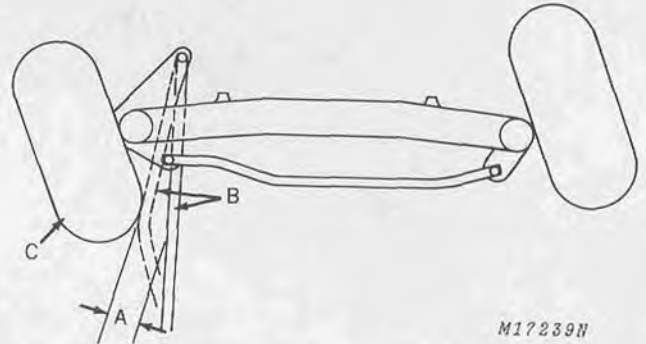

A—Clearance Between Drag Link and Tire
B—Drag Link Positions
C—Tire

Fig. 20-Steering Linkage Adjustment
Viewed from Top of Tractor

The overall length of the drag link determines left and right turning radius.

To equalize turning radius, disconnect the drag link from lever arm. Point wheels straight ahead.

Turn steering wheel through its full range, counting the number of turns. Turn wheel half-way back. Loosen jam nuts at the drag link. Then lengthen or shorten drag link until it can be attached to lever arm.

If drag link interferes with left front tire, loosen drag link ball joint jam nuts. Rotate drag link inward (toward center of the tractor). Lock ball joint jam nuts and re-test for equal turning.

TORQUE FOR HARDWARE

Location	Torque
Steering gear plug	10 to 14 ft-lbs (13.6 to 17.6 Nm)
Lever arm cross bolt	22 to 25 ft-lbs (29.8 to 33.9 Nm)
Jam nut on lever arm stud	40 ft-lbs (54.2 Nm)
Steering wheel retaining nut	10 to 12 ft-lbs (13.6 to 16.3 Nm)

Group 10 FRONT WHEELS AND AXLES

INTRODUCTION

Refer to Group 5, "Steering Linkage" for service and adjustment of all linkage related to the front wheels. Group 5 includes service of ball joints,

drag link, tie rod, toe-in adjustment, etc. This group covers only front wheel spindles, bearings and axle.

REPAIR

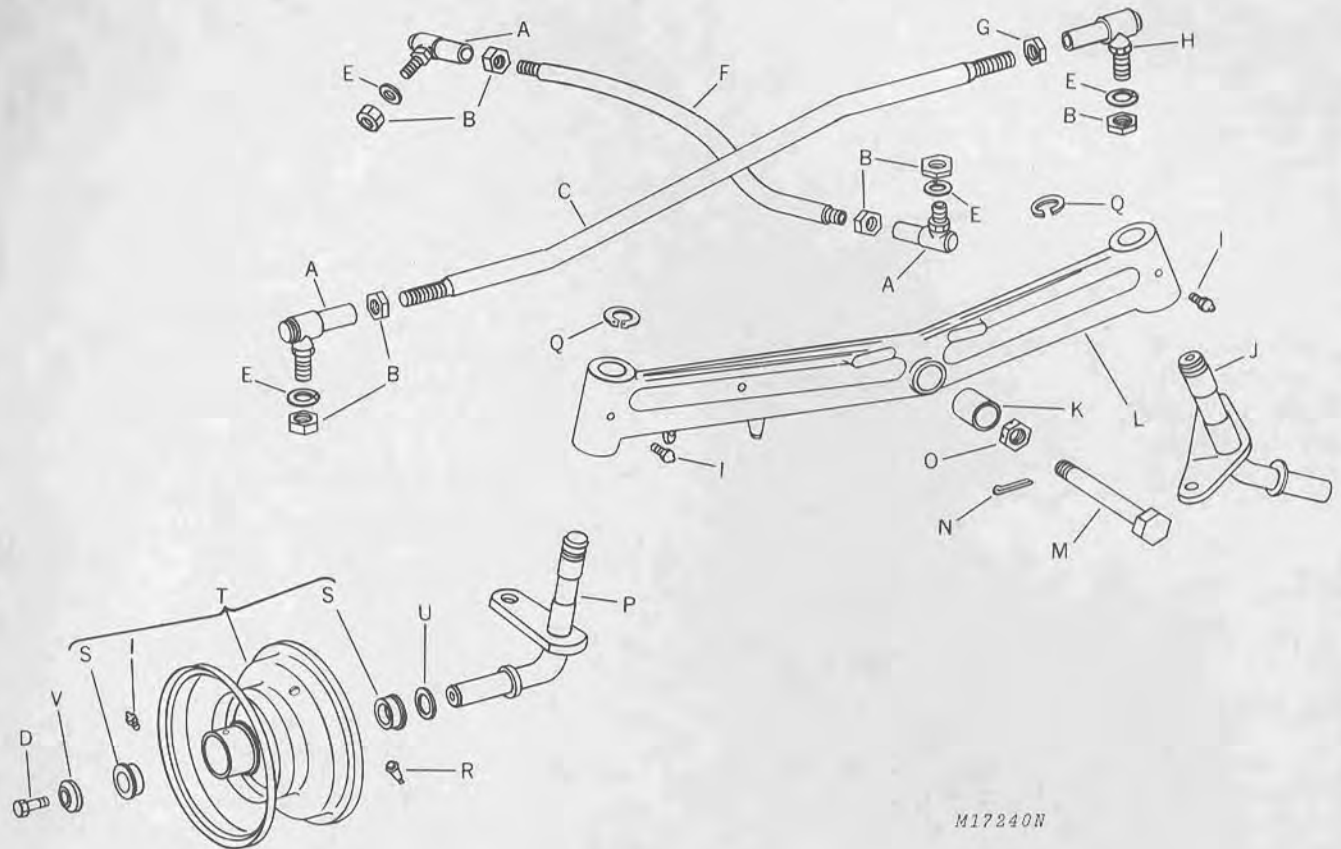

M17240N

- | | | |
|-----------------------------|-----------------------------|----------------------------|
| A—Ball Joint Assembly | I —Grease Fitting | P—R.H. Front Wheel Spindle |
| B—Jam Nut with R.H. Threads | J —L.H. Front Wheel Spindle | Q—Snap Ring |
| C—Tie Rod | K—King Pin Bushing | R—Valve Stem |
| D—Cap Screw | L—Axle with Bushing | S—Bearing |
| E—Lock Washer | M—King Pin Bolt | T—Front Wheel Disk |
| F—Drag Link | N—Cotter Pin | U—Spring Washer |
| G—Jam Nut with L.H. Threads | O—Slotted Nut | V—Spindle Cap |
| H—Ball Joint Assembly | | |

Fig. 1-Exploded View of Front Wheels and Axles

Removing Front Wheels

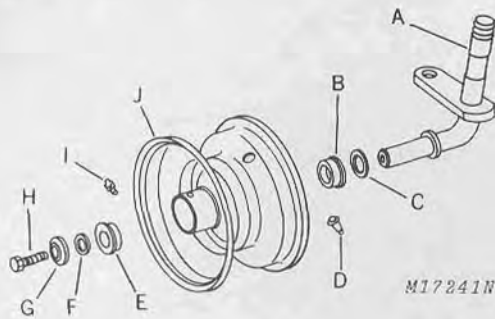

- | | |
|-----------------|------------------|
| A—Spindle | F—Washer |
| B—Inner Bearing | G—Spindle Cap |
| C—Spring Washer | H—Cap Screw |
| D—Valve Stem | I—Grease Fitting |
| E—Outer Bearing | J—Wheel |

Fig. 2—Removing Front Wheel Components from Spindle

Jack up tractor until wheel clears the ground. Remove cap screw (H), Fig. 2. Remove spindle cap (G), outer bearing (E), wheel (J), inner bearing (B) and spring washer (C).

Removing Spindle From Axle

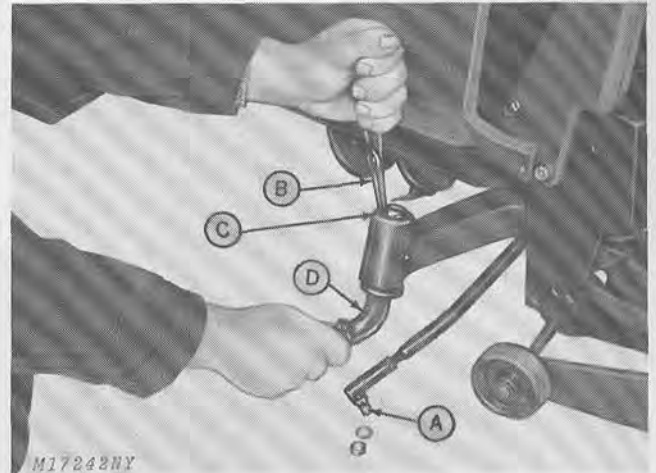

- | | |
|--------------------|-------------|
| A—Tie Rod End | C—Snap Ring |
| B—Snap Ring Pliers | D—Spindle |

Fig. 3—Removing Snap Ring

To remove spindle (D), disconnect tie rod end (A), and using a snap ring pliers (B), remove snap ring (C) from spindle (D), Fig. 3. Slip spindle (D) out of axle.

Inspecting Bearings

Refer to page 20-20-11, to determine bearing condition. Service as necessary.

INSTALLATION

Installing Axle

Grease king pin assembly and install axle (A), Fig. 4. Tighten king pin bolt (B) until it takes 25 to 75 lbs (11.34 to 34.02 kg) force at the end of the axle to rotate it up or down. Secure slotted nut (C) with cotter pin (D).

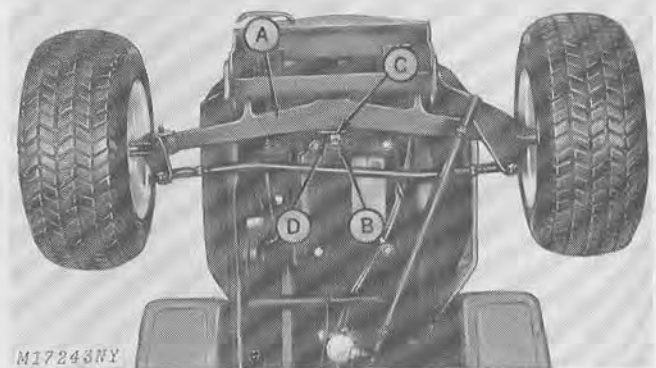

- | | |
|-----------------|---------------|
| A—Axle | C—Slotted Nut |
| B—King Pin Bolt | D—Cotter Pin |

Fig. 4—Installing Axle on Tractor

Installing Spindles

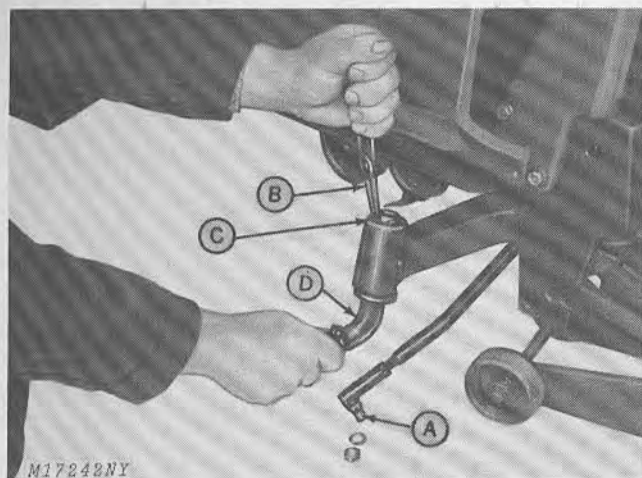

- | | |
|--------------------|-------------|
| A—Tie Rod End | C—Snap Ring |
| B—Snap Ring Pliers | D—Spindle |

Fig. 5—Installing Front Axle Spindles and Front Wheels

Apply a light coat of grease on upper spindle shaft. Install spindle (D) into axle, Fig. 5. Secure with snap ring (C).

Installing Bearings and Wheels

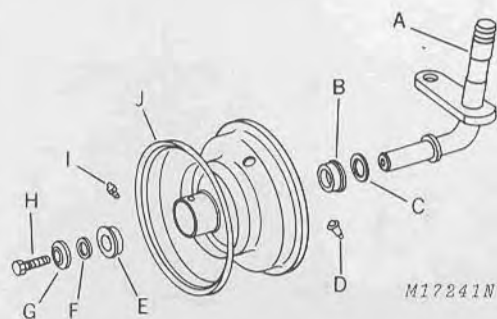

- | | |
|-----------------|------------------|
| A—Spindle | F—Washer |
| B—Inner Bearing | G—Spindle Cap |
| C—Spring Washer | H—Cap Screw |
| D—Valve Stem | I—Grease Fitting |
| E—Outer Bearing | J—Wheel |

Fig. 6—Installing Bearings and Wheels

Pack wheel bearings with John Deere Multipurpose Lubricant or an equivalent SAE multipurpose-type grease.

Install spring Washer (C), inner bearing (B), wheel (J), outer bearing (E), washer (F), spindle cap (G) and cap screw (H), Fig. 6.

NOTE: There is no adjustment necessary on the front wheel bearings.

Group 15 LIFT LINKAGE

GENERAL INFORMATION

Manual Lift

The manual lift linkage, for the 200 Series Tractors, normally doesn't require adjustment or service other than lubrication.

If parts become worn or damaged, they must be replaced.

Connecting Link

If correct lifting or lowering travel cannot be achieved with attachment linkage, adjust the length of the connecting link (E). This will change the travel up or down on the manual lift.

The proper link length is 11.9 inches (302.3 mm) from the center of each yoke.

Helper Spring Kit

The helper spring (H) is available for mounted equipment such as the snow thrower, front blade, rotary tiller, and integral hitch.

When installed, the helper spring decreases the effort required to raise heavy equipment with the manual lift lever.

Depth Control

Proper adjustment of the depth control (I) allows the mower or center blade to return to the same pre-set height each time it is raised and lowered.

The depth control allows the operator to lock the mower or center blade in the raised position while using the manual lift lever to operate front- or rear-mounted equipment.

NOTE: Front- or rear-mounted equipment cannot be locked in the raised position with the depth control knob.

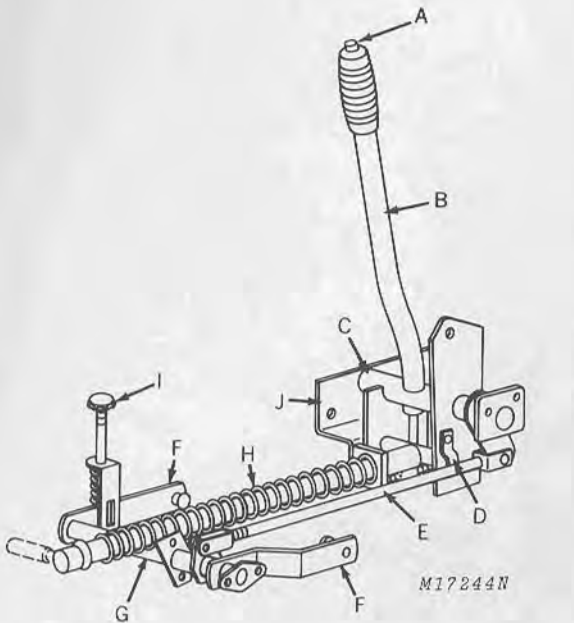

- | | |
|----------------------|------------------------|
| A—Thumb Release | F—Mower Lift Link |
| B—Lift Lever | G—Secondary Lift Shaft |
| C—Primary Lift Shaft | H—Helper Spring |
| D—Offset Pin | I—Depth Control |
| E—Connecting Link | J—Quadrant |

Fig. 1—Manual Lift Linkage

DIAGNOSING MALFUNCTIONS

Hard Lifting.

No helper spring (extra equipment) or improper spring tension. Install spring or increase tension to reduce lift effort.

Lift shaft and/or lift shaft hub needs lubrication.

Lift Lever Breakage.

No helper spring (extra equipment) or improper spring tension. Install spring or increase tension to reduce lift effort.

Lift lever not properly seated in lever hub.

Very Little Lift.

Lift rod not properly adjusted (rod from secondary lift shaft arm to front-mounted equipment).

Turn yoke onto lift rod.

Connecting link not properly adjusted (rod between primary and secondary lift shaft).

Turn yoke onto link.

No Lift When Lift Lever is in Fully Raised Position.

Connecting link not properly adjusted (rod between primary and secondary lift shaft) for mower, integral hitch and tiller.

Lift rod not properly adjusted for front-mounted equipment.

Broken weld on primary lift shaft (in pedestal).

Lift Lever Will Not Stay in Raised Position.

Weak or broken release rod spring.

Thumb release not properly seated on release rod.

Very Little Down Travel.

Depth control screw turned all the way down.
Turn depth control counterclockwise.

Lift rod not properly adjusted for front-mounted equipment.

Connecting link not properly adjusted (rod between primary and secondary lift shaft).

Lift Lever Hard to Move Forward.

Helper spring too tight.

Loosen spring tension (release all tension when using mower).

Lift shaft and/or lift shaft hub needs lubrication.

Lift lever not properly seated in lift lever hub.

Group 20 ATTACHMENTS

PREPARING TRACTOR

Before installing any attachment on tractors, inspect tractor to be sure it is in proper running order. Check all tractor adjustments.

Adjusting Lift Connecting Link

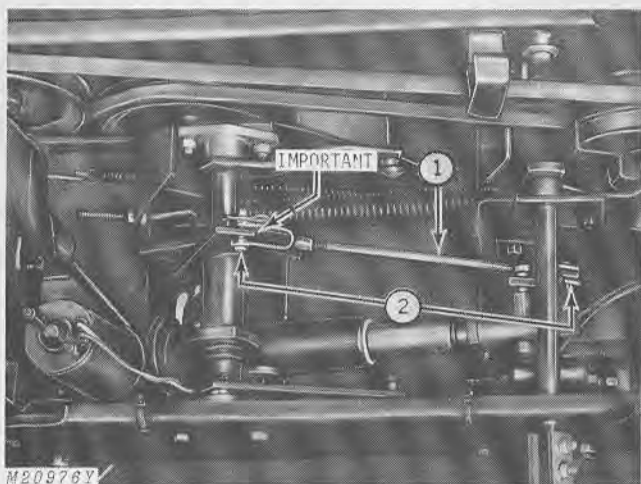

Fig. 1-Adjusting Connecting Link

1. Especially when using a power lift such as the electric lift or hydraulic lift, adjust the connecting link between the primary and secondary lift shafts. Make the connecting link adjustment as follows before making any adjustments to the attached equipment.

2. Disconnect the connecting link and adjust by turning the clevis until the proper length of 11.9 inches (302.26 mm) between the centers of the clevis pin holes is obtained. Reinstall connecting link.

IMPORTANT: When reinstalling the connecting link, be sure the stop on the secondary lift shaft is toward the front so the lift arms must be raised slightly to connect the link.

Adjusting Rear Wheel Tread

If the tractor is to be used on steep hills, move the rear wheels to the wide wheel tread position for increased tractor stability.

Tractors with GT-3 or GT-5 High-Flotation Tires

Remove wheel bolts; turn wheel around with valve stem inward, and reassemble wheel on hub.

Tractors with GT-4 or GT-8 Traction Tires

Remove wheel bolts, turn wheel around with valve stem inward and reassemble each wheel on the opposite side of the tractor. Interchanging right-hand and left-hand rear wheels is required to maintain the proper direction of rotation for traction tires. Tread (and arrow) on tire must point forward in direction of travel.

Checking Electric Lift (Extra Equipment)

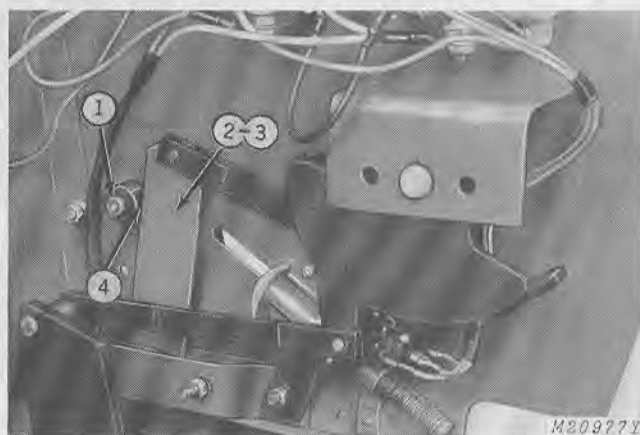

Fig. 2-Adjusting Stop Screw

On tractors with an electric lift, check the electric lift stop spacer on the left-hand pedestal side.

To check, pull the control lever all the way to the rear.

After the lift has traveled to its fully raised position, turn the key switch off. If the lift solenoid clicks, adjustment is necessary.

1. To adjust, loosen the stop spacer bolt.
2. Pull control lever to the rear.
3. Move the lever forward until the key switch can be turned on and off without activating the lift solenoids.
4. Move the spacer forward until it touches the control switch arm and tighten.

ADJUSTING ATTACHMENT LIFT

37A Snow Thrower

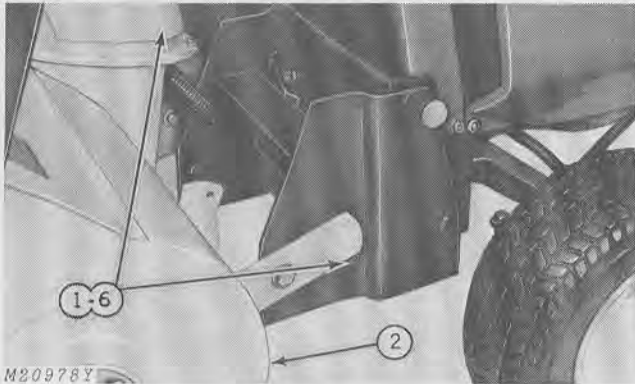

Fig. 3-Raising Snow Thrower

1. On snow throwers, (Serial No. 30,001-) raise until the stop arm touches the stop on the mounting plate. On snow throwers (Serial No. -30,000) raise until the chute just clears the hood.

2. Block the snow thrower in this position.

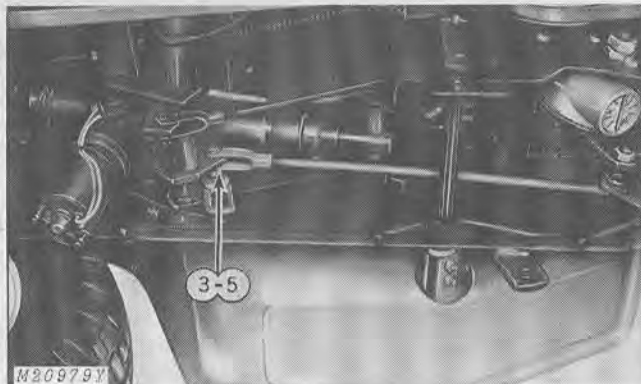

Fig. 4-Adjusting Lift Link

3. Disconnect the clevis on the lift rod at the secondary lift shaft.

4. Pull the lift lever all the way to the rear (or raised position).

NOTE: (Electric lift equipped tractors.) When the lift stops, check that the control switches have returned to neutral position by turning the key switch on and off. If the lift solenoids click, the switches have not returned to neutral position. Correct by adjusting the stop spacer.

5. Adjust the clevis on the lift rod until the rod can be reattached to the secondary lift shaft.

At this point, turn the clevis onto the rod approximately four complete turns (this will allow for slack in the linkage). Move the lift control lever forward and attach the lift rod clevis to the secondary lift shaft.

6. Move the control lever to the rear and check that the arm on snow throwers (Serial No. 30,001-) just touches the stop or the chute clears the hood on snow throwers (Serial No. -30,000), Fig. 3.

43 Front Blade

Attach the front blade to the tractor.

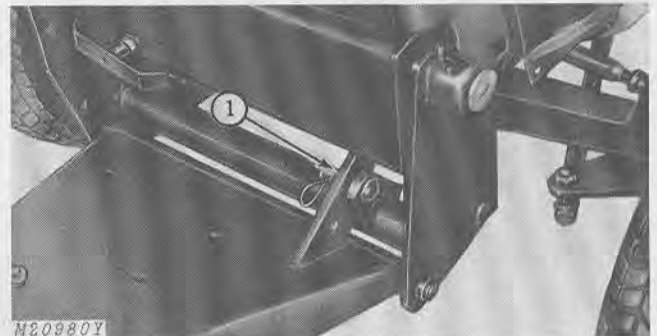

Fig. 5-Lift Blade in Transport Position

1. Lift the blade to transport position and pin it in this position.

2. Disconnect the rear lift rod clevis at the secondary lift shaft. Pull the lift control lever all the way to the rear. When the tractor is equipped with an electric lift, check that the control switches have reached neutral position. (See "Checking Electric Lift," page 70-20-1).

3. Turn the clevis on the lift rod until it can be attached, then turn the clevis approximately four complete turns further onto the lift rod, Fig. 4.

Move the control lever forward until the lift rod can be attached to the secondary shaft.

4. After attaching the lift rod, pull the lift lever to the rear, then check the following conditions.

A. The transport pin can be removed by hand.

B. When tractor is equipped with an electric lift, the control switches must reach a neutral position.

43 Center Blade also 39 and 47 Rotary Mowers



Fig. 6-43 Center Blade

1. When these attachments are on the tractor, the lift should be able to operate to its full stroke without interfering with the fender-deck or frame.

2. If interference is observed, the connecting link between the primary and secondary lift shaft is too short. The proper length is 11.9 inches (302.26 mm) between the center of the clevis pin holes. (Refer to "Adjusting Lift Connecting Link", page 70-20-2).

31 Tiller



Fig. 7-31 Tiller

1. Attach the tiller to the tractor. Raise tiller to a transport height of 14 inches (356 mm) from the ground to the top of the tine shaft. Block the tiller in this position.

NOTE: The lift link should be attached to the upper hole in the pivot arm on the tractor.

TROUBLE SHOOTING

Machine	Problem	Possible Cause
43 Front Blade	Ground will not grade level.	Skid shoe out of adjustment.
	Blade does not lift properly.	Lift rod disconnected. Lift rod not properly adjusted or bent.
31 Tiller	Tine shaft does not rotate.	Foreign material wrapped around tine shaft. Drive belts slipping. Drive pin sheared. Broken drive shaft.
	Tine shaft rotates but tiller does not till ground.	Foliage prevents tiller penetration. Tine shaft rotating in reverse. (Drive belt improperly installed.) Tractor speed too fast for conditions. Chain jumps on sprocket.
	Tiller lifts hard.	Position lift link in upper hole. Tractor helper spring needs adjustment. Foliage wrapped around shaft. Mud or dirt caked onto housing and tine shaft.
	Erratic tiller operation.	Broken tine. Foreign material wrapped around tine shaft.
37A Snow Thrower	Rotor does not rotate.	Drive belt worn or broken. Drive chain tension needs adjustment. Drive chain needs replacement.
	Snow thrower operates erratically.	Scraper blade damaged (reverse it). Adjust rotor drive chain tension. Lubricate snow thrower.
	Rear wheels slip.	Install rear wheel weights.
39 and 47 Rotary Mower	Mower cuts unevenly or scalps.	Ruff terrain. Gauge wheels not properly adjusted. Mower blade bent or damaged. Spindle damaged. Lift linkage not properly adjusted.

SERVICE INTERVAL CHART

Attachment	Service Interval		
	At start of season	Hours of operation	At end of season
39 and 47 Rotary Mowers	<ol style="list-style-type: none"> Sharpen, balance, and straighten blades. Check spindles for wear or damage. Check blade alignment. Check mower deck belt for cracks or wear. Check idler spring for wear or fatigue. Check PTO drive belt for cracks or wear. 	At beginning and end of each mowing season.	<ol style="list-style-type: none"> Clean mower deck and under belt shield. Repaint chipped areas to prevent rust.
37A Snow Thrower	<ol style="list-style-type: none"> Check rotor drive chain tension. Check drive belt for cracks or wear. 	<ol style="list-style-type: none"> Lubricate counter-shaft every 5 hours of operation. Apply several drops of SAE 30 oil to all pivot points every 5 hours of operation. 	<ol style="list-style-type: none"> Check scraper blade for damage. Clean snow thrower and repaint chipped or rusted areas.
43 Front Blade 43 Center Blade	No special maintenance required except each year. Repaint chipped or rusting parts and repair or replace worn or damaged parts.		
31 Rotary Tiller	<ol style="list-style-type: none"> Check drive chain. Check external drive chain. Check primary drive belt. Check tiller drive belt. 	<ol style="list-style-type: none"> Oil bushings lightly every 8 hours of operation. Every 50 hours of operation grease grease fittings on lower pivot and pivot plate. Repack needle bearings every 50 hours of operation. 	<ol style="list-style-type: none"> Repack tiller drive sheave needle bearings. Replace upper bearings in chain case. Replace lower bearings in chain case.

Section 80

SPECIAL SERVICE TOOLS

Group 5

ENGINE CONVENIENCE SERVICE TOOLS

CONTENTS

GROUP 5 - ENGINE CONVENIENCE SERVICE TOOLS	5-2
GROUP 10 - TRACTOR ESSENTIAL SERVICE TOOLS	10-1
GROUP 15 - TRACTOR CONVENIENCE SERVICE TOOLS	15-1

NOTE: No engine essential service tools are required to service 200 Series Tractor engines. Engine convenience service tools are listed in Group 5. They are not required either, but will make the job quicker and easier.

ENGINE CONVENIENCE SERVICE TOOLS

The engine convenience service tools listed in this group are strictly for the convenience of the mechanic. They are not required, but they will make the job quicker and easier.

They can be ordered from:

Service Tools
Division of Owatonna Tool Company
P.O. Box 314
Owatonna, Minnesota 55060

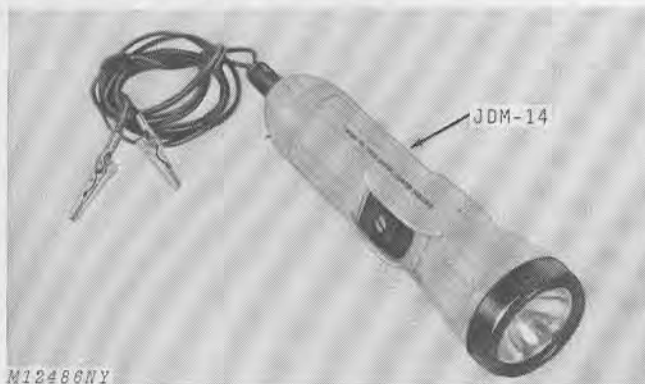

M12488NY

Fig. 1-JDM-14 Continuity Tester

JDM-14 Continuity Tester, Fig. 1, is used to locate open or closed electrical circuits.

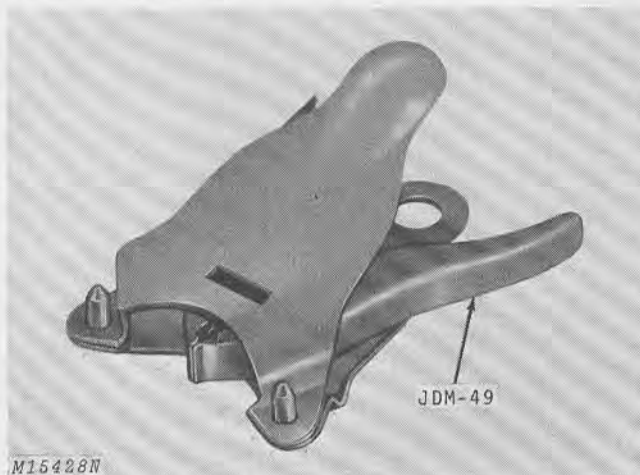

M15428N

Fig. 2-JDM-49 Piston Ring Expander

For Kohler, Briggs & Stratton and Tecumseh Engines.

JDM-49 Piston Ring Expander, Fig. 2, removes or installs rings on pistons up to 4 inches (1.01 cm) in diameter.

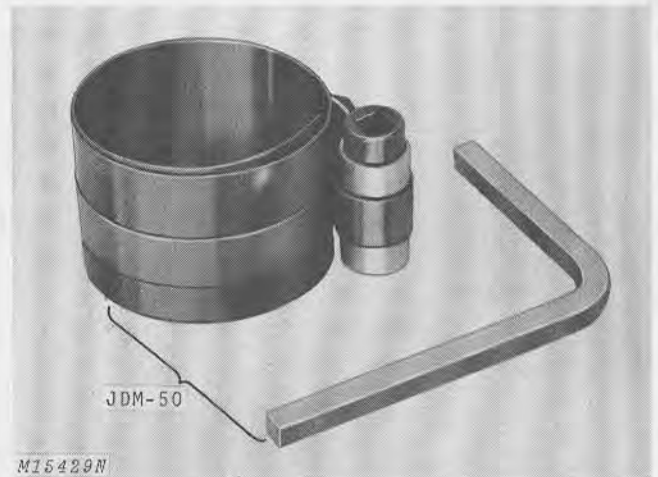

M15429N

Fig. 3-JDM-50 Piston Ring Compressor

For Kohler, Briggs & Stratton and Tecumseh Engines.

JDM-50 Piston Ring Compressor, Fig. 3, compresses rings on piston from 1-3/4 inches to 3-1/2 inches (44.45 to 88.90 mm) in diameter for installation in aluminum or cast iron cylinders.

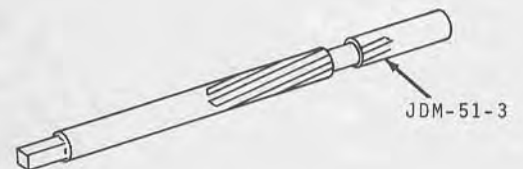

M17252N

Fig. 4-JDM-51-3 Valve Guide Reamer

JDM-51-3 Valve Guide Reamer, Fig. 4, is used on both Kohler or Tecumseh engines to clean carbon from standard size valve guides or to enlarge standard guides to accept oversize valve stems.

Size is 0.312-inch (7.92 mm) diameter.

NOTE: If you also service Tecumseh engines, you may want to order the JDM-51 Valve Guide Reamer Set which includes the JDM-51-3 Reamer plus the following:

- JDM-51-1 Valve Guide Reamer 0.0250 in. (6.35 mm)
- JDM-51-2 Valve Guide Reamer 0.0281 in. (7.13 mm)
- JDM-51-4 Valve Guide Reamer 0.343 in. (8.71 mm)

The above reamers can be purchased separately by ordering the individual number.

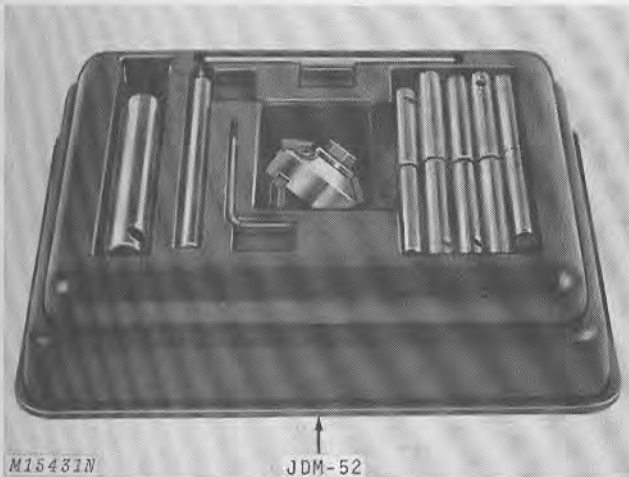
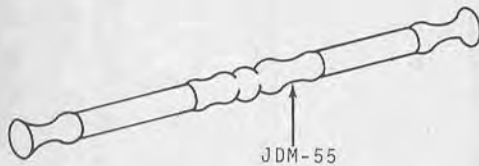

Fig. 5-JDM-52 Valve Seat Service Set

For Kohler, Briggs & Stratton and Tecumseh Engines.

JDM-52 Valve Seat Service Set, Fig. 5, is a complete hand-operated, precision valve seat reconditioning kit.



M15433N

Fig. 6-JDM-55 Valve Lapper

For Kohler Engines.

JDM-55 Valve Lapper, Fig. 6, permits hand-lapping flat-head unslotted valves. Valve lapper has 15/16-inch (23.82 mm) and 1-1/16-inch (26.97 mm) cups.

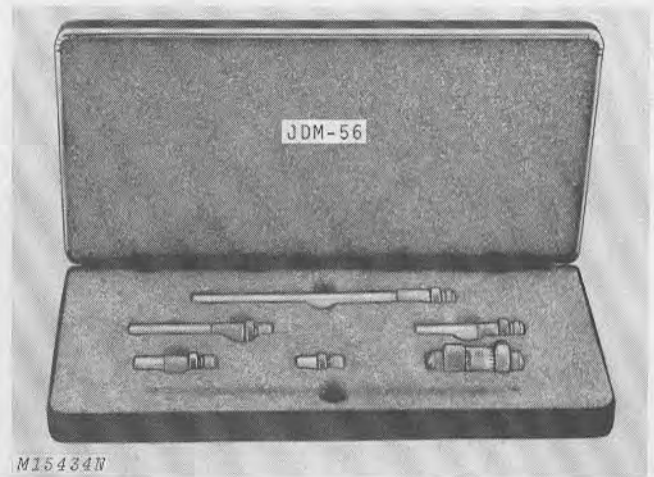

Fig. 7-JDM-56 Inside Micrometer Set

For Kohler, Briggs & Stratton and Tecumseh Engines.

JDM-56 Inside Micrometer Set, Fig. 7, has six micrometers for checking inside diameters ranging from 1-1/2 inches to 8 inches.

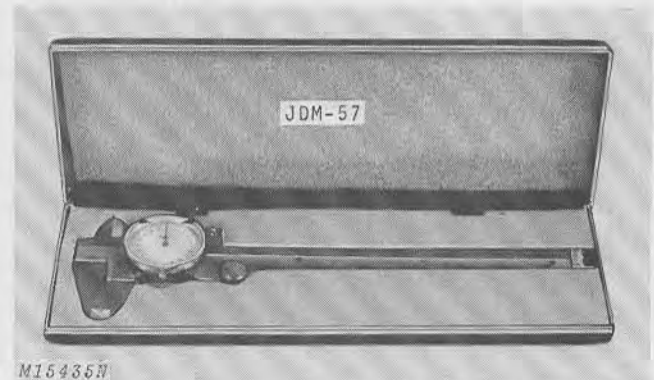

Fig. 8-JDM-57 Dial Caliper

For Kohler, Briggs & Stratton and Tecumseh Engines.

JDM-57 Dial Caliper, Fig. 8, measure outside or inside dimensions from 0 to 6 inches in increments of 0.001 inch.

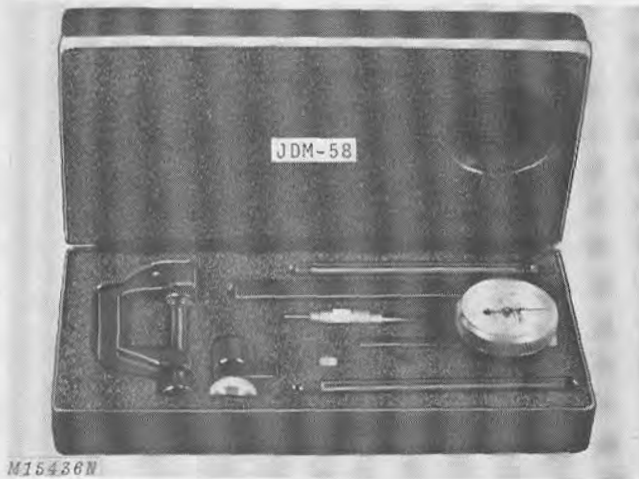

Fig. 9-JDM-58 Dial Indicator Set

For Kohler, Briggs & Stratton and Tecumseh Engines.

JDM-58 Dial Indicator Set, Fig. 9, measure end play or out-of-round conditions. Set includes holder, clamp, hole attachment, connector, rods, contacts, and dial with 0.200-inch range in increments of 0.001-inch reading from 0 to 100.

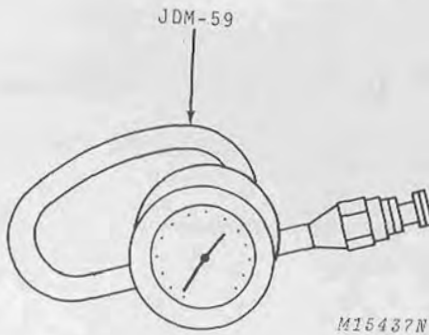

Fig. 10-JDM-59 Compression Gauge

For Kohler and Tecumseh Engines.

JDM-59 Compression Gauge, Fig. 10 is capable of measuring up to 300 lbs. pressure. Use in 14 mm and 18 mm spark plug holes.

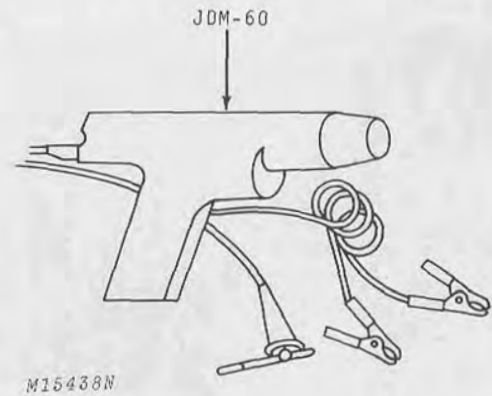

Fig. 11-JDM-60 Power Timing Light

For Kohler Engines

JDM-60 Power Timing Light, Fig. 11, is used to quickly and accurately establish timing.

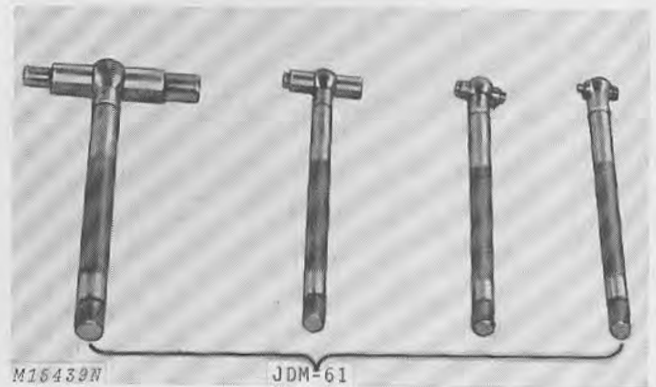

Fig. 12-JDM-61 Telescoping Gauge Set

For Kohler, Briggs & Stratton and Tecumseh Engines.

JDM-61 Telescoping Gauge Set, Fig. 12, measures inside dimensions from 5/16 inch to 2-1/8 inches.

Dial Caliper JDM-57 is used to read the dimension.

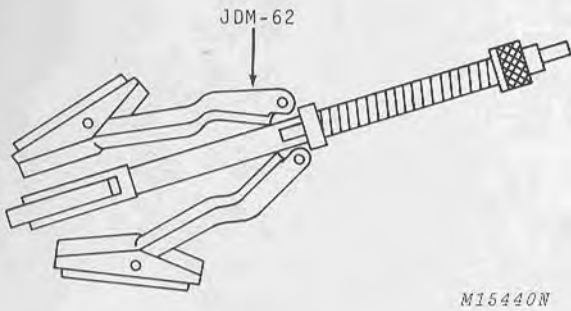

Fig. 13-JDM-62 Glaze Breaker

For Kohler Engines

JDM-62 Glaze Breaker, Fig. 13, is used with an electric drill to deglaze case iron cylinder walls to assure positive ring seating. It fits all cast iron cylinders from 2 to 5-1/4 inches (50.80 mm to 1.33 cm).

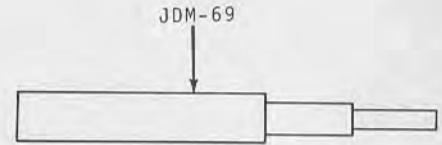

Fig. 15-JDM-69 Valve Guide Driver

JDM-69 Valve Guide Driver, Fig. 15, is used to remove old valve guides and install new guides.

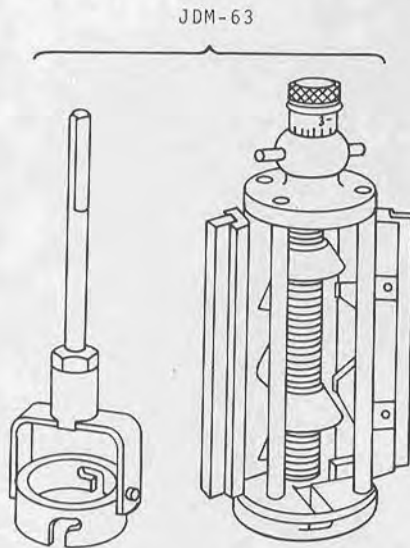

Fig. 14-JDM-63 Cylinder Hone Set

For Kohler and Tecumseh Engines.

JDM-63 Cylinder Hone Set, Fig. 14, hones cylinder bore in case iron engines. Set includes the following:

- Roughing Stone Set
- Medium Stone Set
- Fine Stone Set
- 12 Ounces of Honing Oil

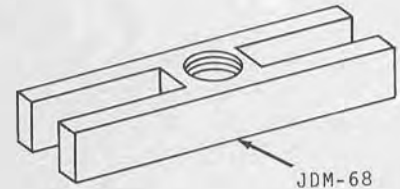

Fig. 16-JDM-68 Flywheel Puller

JDM-68 Flywheel Puller, Fig. 16, allows easy removal of flywheel. Can be adapted for many other uses.

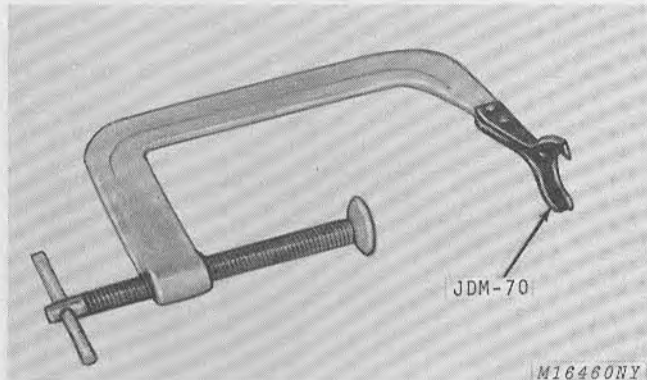

Fig. 17-JDM-70 Valve Spring Compressor

For Kohler and Briggs & Stratton Engines

JDM-70 Valve Spring Compressor, Fig. 17, compresses valve springs to remove or install intake and exhaust valves.

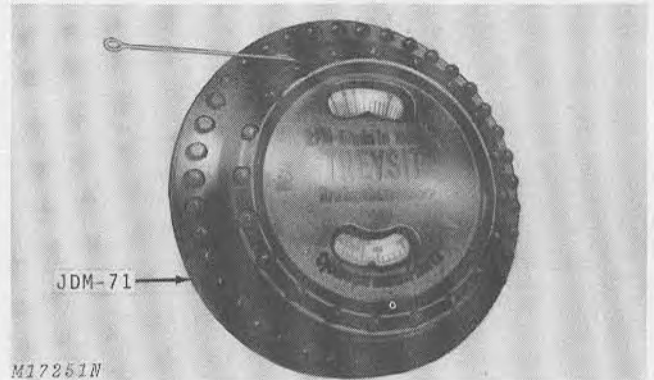

Fig. 18-JDM-71 Vibration Tachometer

JDM-71 Vibration Tachometer, Fig. 18, is a multi-purpose precision instrument. It measures speeds from 800 to 25,000 rpm. It also measures oscillations and vibrations from 14 to 400 per second.

Group 10 TRACTOR ESSENTIAL SERVICE TOOLS

TRACTOR ESSENTIAL SERVICE TOOLS

These essential tools are required for all consumer products dealers.

They can be ordered from:

Service Tools, Inc.
1901 Indiana Avenue
Chicago, Illinois 60616

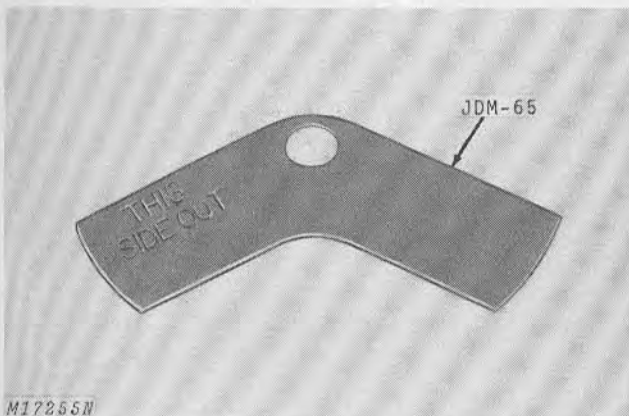

Fig. 1-JDM-65 Electric Lift Cam Template

JDM-65 Electric Lift Cam Template, Fig. 1, is used to adjust the electric lift cam on 200 Series Tractors.

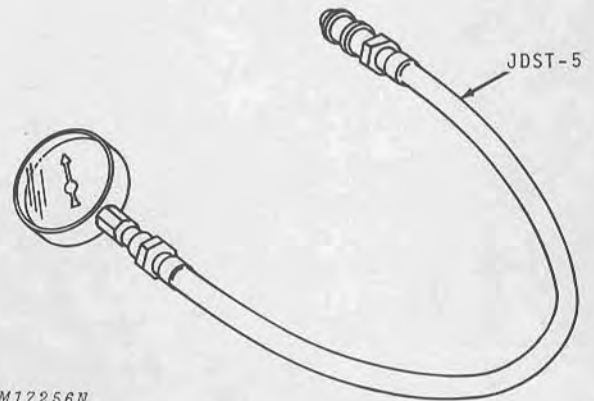

Fig. 2-JDST-5 Hydraulic Pressure Gauge

JDST-5 Test Gauge Assembly, Fig. 2, is used for checking hydraulic system pressure on 200 Series Tractors.

It can also be used to check charge pressure and implement operating pressure on the 300 and 400 Hydrostatic Tractors.

Group 15

TRACTOR CONVENIENCE SERVICE TOOLS

TRACTOR CONVENIENCE SERVICE TOOLS

The tractor convenience service tools listed in this group are strictly for the convenience of the

mechanic. They are not required, but they will make the job quicker and easier.

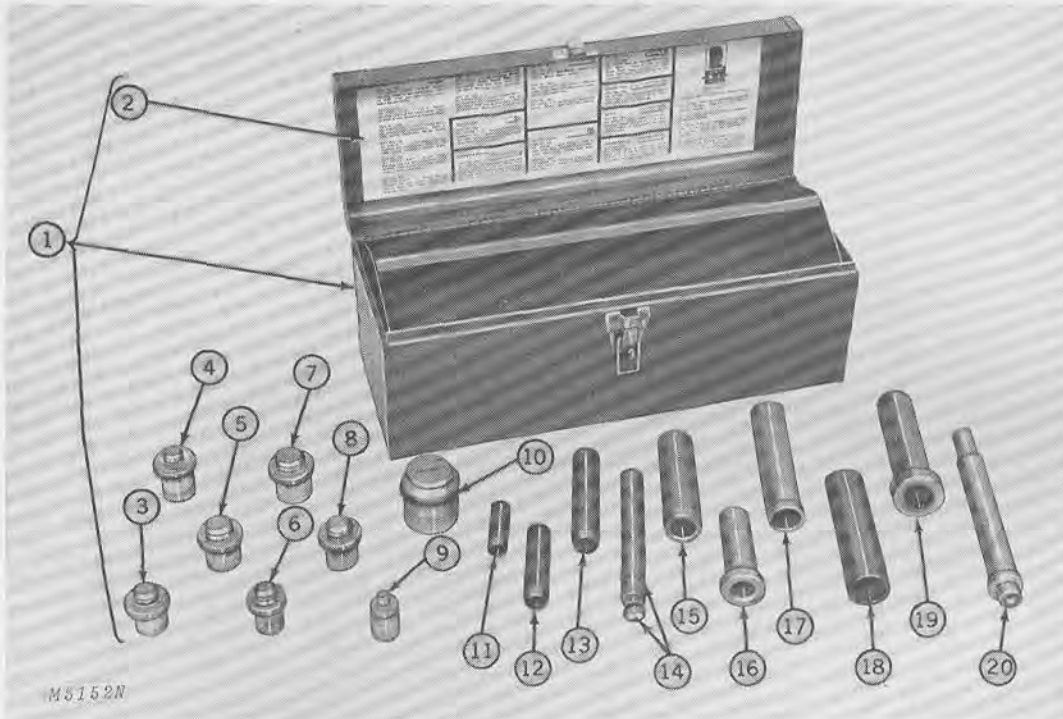

Fig. 1-Tools for Servicing Transaxle

Key	Part No.	Description
1	670188	Transaxle Tool Kit (Includes all parts listed below)
2	691246	Instructions Sheet
3	670173	Tool, 1" - 1-1/4" Bearing Assembly and Disassembly
4	670176	Tool, 3/4" - 1-1/4" Bearing Assembly and Disassembly
5	670171	Tool, 15/16" - 1-3/16" Bearing Assembly and Disassembly
6	670175	Tool, 3/4" - 1" Bearing Assembly and Disassembly
7	670170	Tool, 1-1/8" - 1-3/8" Bearing Assembly and Disassembly
8	670172	Tool, 7/8" - 1-1/8" Bearing Assembly and Disassembly
9	670194	Shifter Shaft Bearing Driver Tool
10	670194	Tool, 1-3/4" - 2-1/8" Bearing Assembly and Disassembly
11	670182	Oil Seal Installation Cone, 3/4"
12	670185	7/8" Seal Sleeve
13	670179	Oil Seal Installation Cone, 1"
14	670177	Burnishing Rod and 7/8" Ball
15	670186	7/8" Shaft Seal Driver
16	670184	Oil Seal and Ball Bearing Installation Tool
17	670180	Oil Seal Installation Tool, 1"
18	670162	Bearing Support
19	28679	1" Ball Bearing Driver
20	670183	Bushing Assembly and Disassembly Tool, 7/8"

Individual items or replacements may be ordered from the above list.

ORDER DIRECT FROM: Lauson-Power Products Parts Depot, Grafton, Wisconsin 53024



Fig. 2-OTC-1340 Snap Ring Pliers

OTC-1340 Snap Ring Pliers, Fig. 2, removes and installs retaining rings.

Order from your Owatonna Tool Company Distributor.

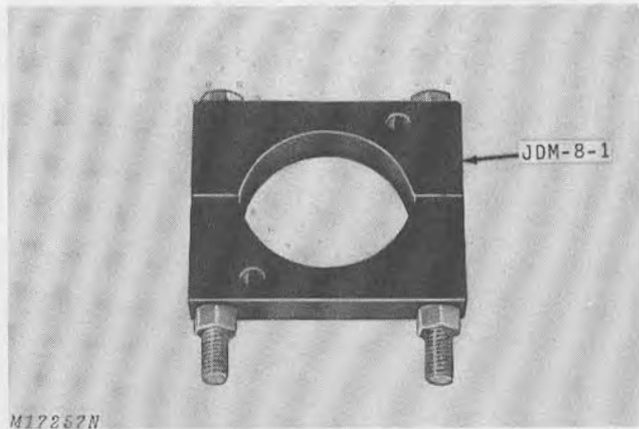

Fig. 3-JDM-8-1 Puller

JDM-8-1 Puller, Fig. 3, is used with OTC 515-A Puller, Fig. 4, to remove steering wheel.

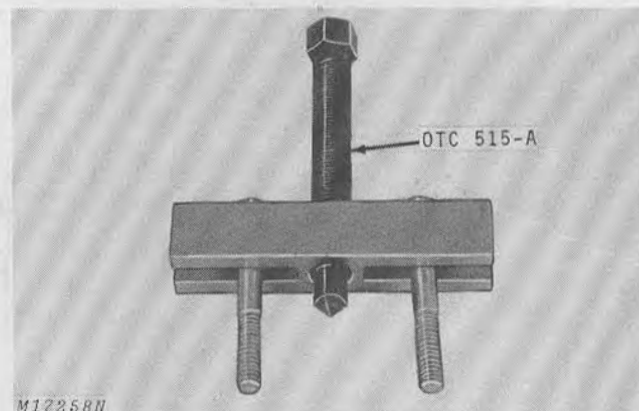

Fig. 4-OTC 515-A Puller

OTC 515-A Puller, Fig. 4, is used in conjunction with JDM-8-1 Puller, Fig. 3, to remove steering wheel. It is also used to pull small gears and pulleys.

PC

Parts Catalog

**John Deere
39 and 47
Rotary Mowers**

PC-1082



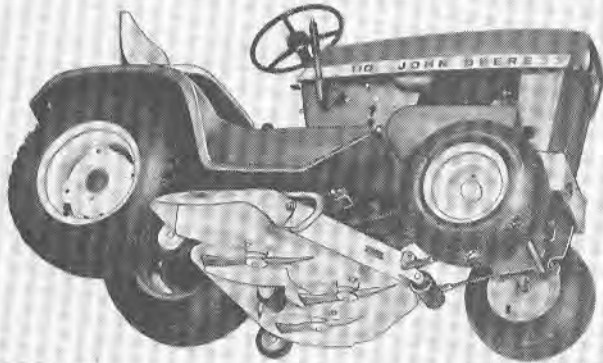

39 Rotary Mower

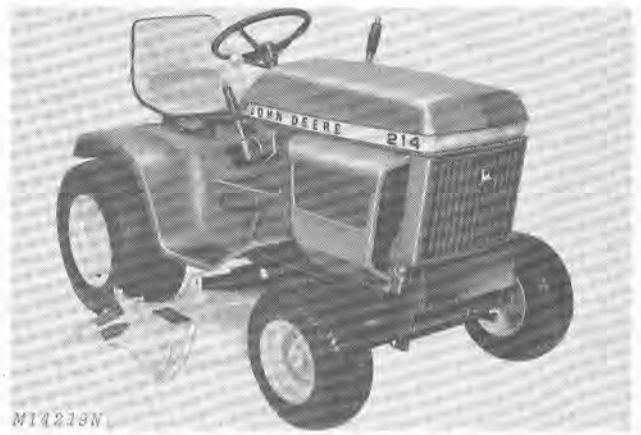

47 Rotary Mower

ALPHABETICAL INDEX

	Page		Page
Decals	7	Guard, chute	2-3
Deck (39 Mower)	2	Rollers (39 Mower)	2
Deck (47 Mower)	3	Rollers (47 Mower)	3
Deck drive	4	Straps, lift	5-6
Draft plate	5-6	Wheels, gauge (39 Mower)	2
Guard, anti-wrap	7	Wheels, gauge (47 Mower)	3

EXPLANATION OF SERIAL NUMBER LISTING

An individual serial number is assigned to each mower. On machines built after June 1974, this number consists of thirteen letters, numbers, or spaces. The first letter indicates the "family of machine" (mower); the next three numbers or letters, the "model or machine designation"; the letter in the fifth position indicates the "model year". This is followed by a space (for computer purposes) and a six-digit serial number and the letter "M" denoting Horicon as the factory of manufacture. When ordering parts, use only the six-digit serial number. When writing about of filling out warranty claims, use all thirteen numbers, letters and spaces shown on the mower serial number plate.

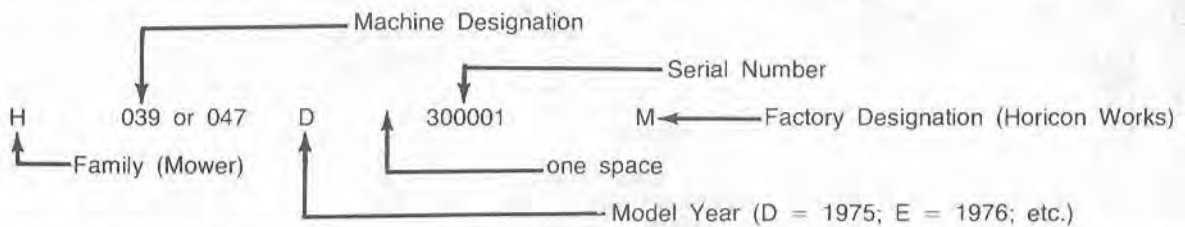

Serial number information is listed parenthetically to show on which machines each part can be used. These listings are explained by the following examples.

- () The part can be used on all machines.
- (000000-) The part can be used on all machines beginning with the serial number listed.
- (-000000) The part can be used on all machines up to and including serial number listed.
- (000000-000000) The part can be used on all machines between and including the serial numbers listed.

Where XXXXXX's are listed in place of a serial number it indicates a serial number change was made but the exact serial number had not been established when the catalog went to press.

EXPLANATION OF PARTS LISTED AS "SERVICE ONLY"

Certain parts in this catalog are listed in the description column as "Service Only". These parts serve as a replacement or additional part for service instead of the part originally furnished. The serial numbers shown lists the machines on which the "Service Only" part may be used.

EXPLANATION OF CHANGE INDICATOR LINE

New and revised information is identified by vertical lines marked in the left-hand margin of revised pages. These lines indicate changes affecting the ordering of parts.

SI (INTERNATIONAL SYSTEM) UNITS OF MEASURE

Metric equivalents have been included, where applicable, throughout this parts catalog.

(Specifications and design subject to change without notice.)

DECK, GAUGE WHEELS AND ROLLERS (39 Rotary Mower)

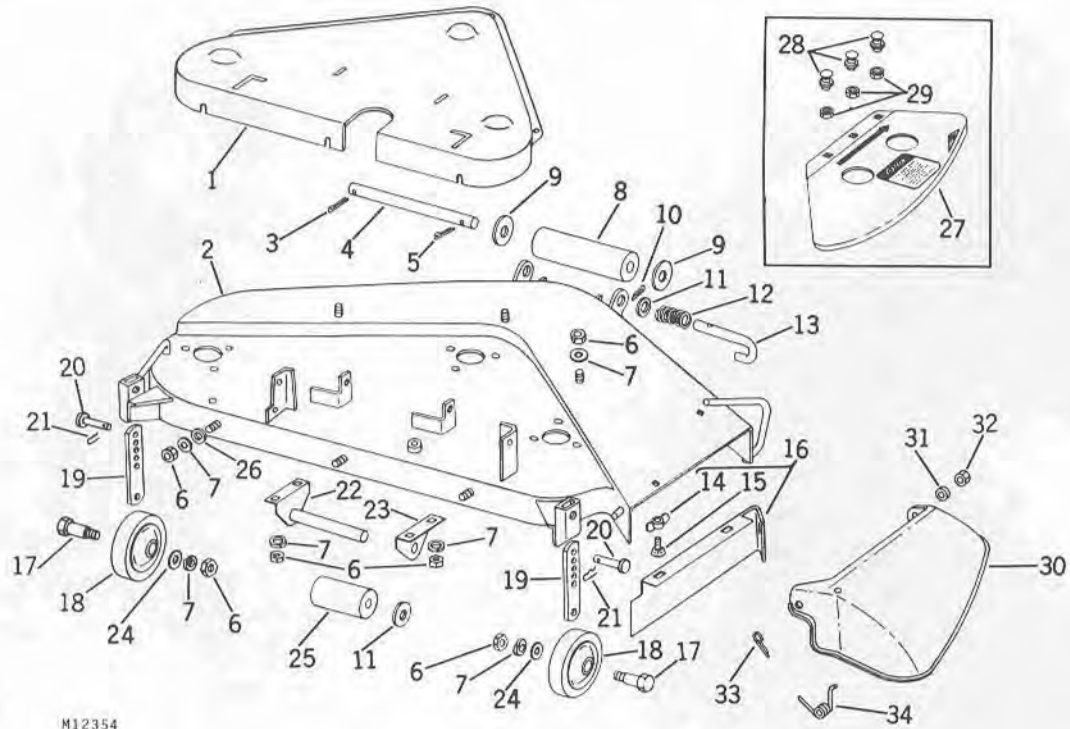

M12354

Key	Part No.	Serial No.	Description
1	M 42778	(-)	Shield
2	AM 31371	(- 190000)	Deck with decals (sub. AM34667)
	AM 34667	(190001 -)	Deck (includes all parts marked with an asterisk on pages 2, 4 and 5)
3	11H 283	(-)	Pin, cotter, 7/32" x 1"
4	M 42276	(-)	Shaft, roller, front
5	11H 284	(-)	Pin, cotter, 7/32" x 1-1/2"
6	14H 812	(-)	Nut, 3/8" (8 used)
7	12H 304	(-)	Washer, lock, 3/8" (8 used)
8	M 41644	(-)	Roller, front, 7"
9	24H 1375	(-)	Washer, 11/16" x 1-1/8" x 0.060" (2 used)
10	11H 280	(-)	Pin, cotter, 5/32" x 3/4" (2 used)
11	24H 1261	(-)	Washer, 9/16" x 1-1/8" x 0.060" (2 used)
12	R 26079	(-)	Spring (2 used)
13	M 42286	(-)	Pin, draft front (2 used)
14	14H 844	(-)	Nut, wing, 1/4" (3 used)
15	3H 1893	(-)	Bolt, cge., 1/4" x 1/2" (3 used)
16	AM 31081	(- 190000)	Plate, leaf mulcher, with hardware (sub. AM34454)
	AM 34454	(190001 -)	Plate, leaf mulcher, with hardware
17	M 40659	(-)	Bolt, gauge wheel (2 used)
18	AM 33718	(-)	Wheel, gauge, 5" (2 used) (sub. for AM30981)
19	M 40653	(-)	Arm, gauge wheel (2 used)
20	M 40569	(-)	Pin, drilled, 3/8" x 1" (2 used)
21	J 16931	(-)	Pin, spring locking (2 used)
22	AM 31011	(-)	Bracket, roller, rear, L.H. with shaft welded
23	M 41981	(-)	Bracket, roller, rear, R.H.
24	24H 1308	(-)	Washer, 13/32" x 1" x 0.090" (2 used)
25	M 40213	(-)	Roller, rear, 4"
26	24H 1305	(-)	Washer, 13/32" x 13/16" x 0.060" (3 used)
27	M 44444	(- 190000)	Guard, chute, with decals
28	3H 1539	(- 190000)	Bolt, cge., 5/16" x 5/8" (3 used)
	12H 303	(- 190000)	Washer, lock, 5/16"
29	M 40699	(- 190000)	Nut, elastic, stop, 5/16" (3 used)
30	AM 34523 *	(190001 -)	Guard, chute, with decals
31	24H 1305 *	(190001 -)	Washer, 13/32" x 13/16" x 0.060"
32	M 47031 *	(190001 -)	Nut, 3/8"
33	11H 236 *	(190001 -)	Pin, cotter, 1/8" x 1"
34	M 47030 *	(190001 -)	Spring

*See Key 2.

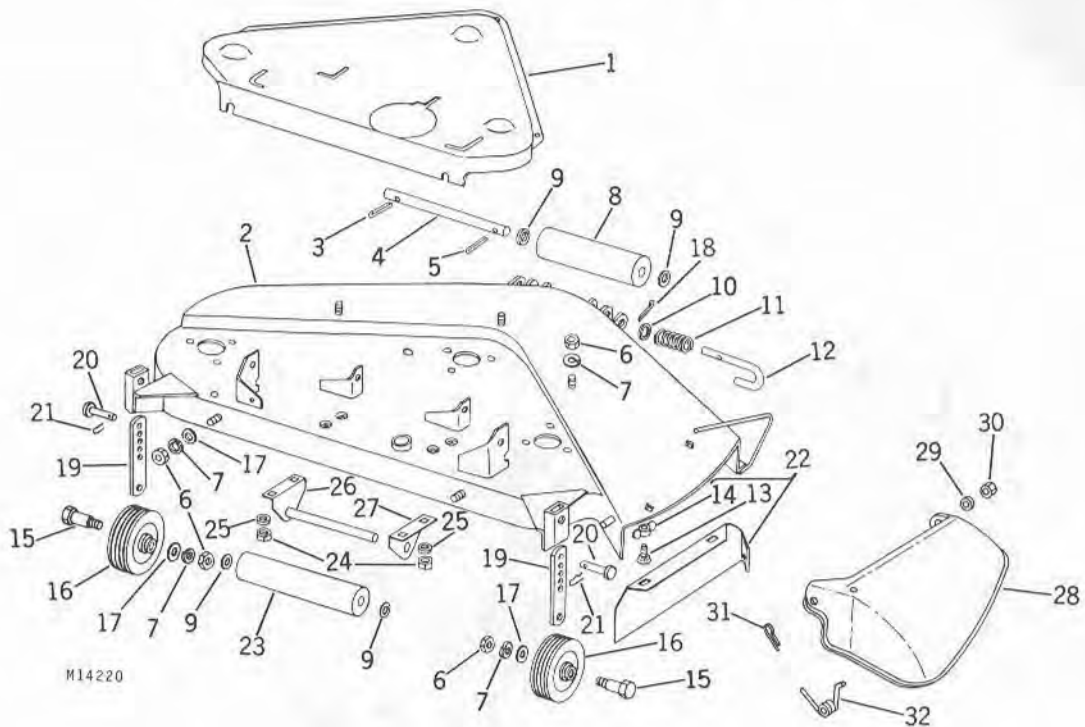
DECK, GAUGE WHEELS AND ROLLERS (47 Rotary Mower)

Key	Part No.	Serial No.	Description
1	M 42796	{ - }	Shield
2	AM 31383	{ - 190000 }	Deck with decals (sub. AM34668)
	AM 34668	{ 190001 - }	Deck (includes all parts marked with an asterisk on this page)
3	11H 283	{ - }	Pin, cotter, 7/32" x 1"
4	M 42276	{ - }	Shaft, roller, front
5	11H 284	{ - }	Pin, cotter, 7/32" x 1-1/2"
6	14H 812	{ - }	Nut, 3/8" (7 used)
7	12H 304	{ - }	Washer, lock, 3/8" (7 used)
8	M 41644	{ - }	Roller, 7"
9	24H 1375	{ - }	Washer, 11/16" x 1-1/8" x 0.060" (4 used)
10	24H 1261	{ - }	Washer, 9/16" x 1-1/8" x 0.060" (2 used)
11	R 26079	{ - }	Spring (2 used)
12	M 42286	{ - }	Pin, draft, front (2 used)
13	3H 1893	{ - }	Bolt, cge., 1/4" x 1/2" (3 used)
14	14H 844	{ - }	Nut, wing, 1/4" (3 used)
15	M 40659	{ - }	Bolt, gauge wheel (2 used)
16	AM 32639	{ - }	Wheel, gauge, 6" (2 used) (sub. for AM31009)
17	24H 1308	{ - }	Washer, 13/32" x 1" x 0.090" (4 used)
18	11H 280	{ - }	Pin, cotter, 5/32" x 3/4" (2 used)
19	M 41979	{ - }	Arm, gauge wheel (2 used)
20	M 40569	{ - }	Pin, drilled, 3/8" x 1" (2 used)
21	J 16931	{ - }	Pin, spring locking (2 used)
22	AM 31013	{ - }	Plate, leaf mulcher, with hardware (sub. AM34455)
23	M 42798	{ - }	Roller, 10"
24	14H 785	{ - }	Nut, 5/16" (4 used)
25	12H 303	{ - }	Washer, lock, 5/16" (4 used)
26	AM 31390	{ - }	Bracket, roller, rear, welded
27	M 42797	{ - }	Bracket, roller, rear
28	AM 34524 *	{ 190001 - }	Guard, chute, with decals
29	24H 1305 *	{ 190001 - }	Washer, 13/32" x 13/16" x .060"
30	M 47031 *	{ 190001 - }	Nut, 3/8"
31	11H 236 *	{ 190001 - }	Pin, cotter, 1/8" x 1"
32	M 47030 *	{ 190001 - }	Spring

* See Key 2

DECK DRIVE ASSEMBLY

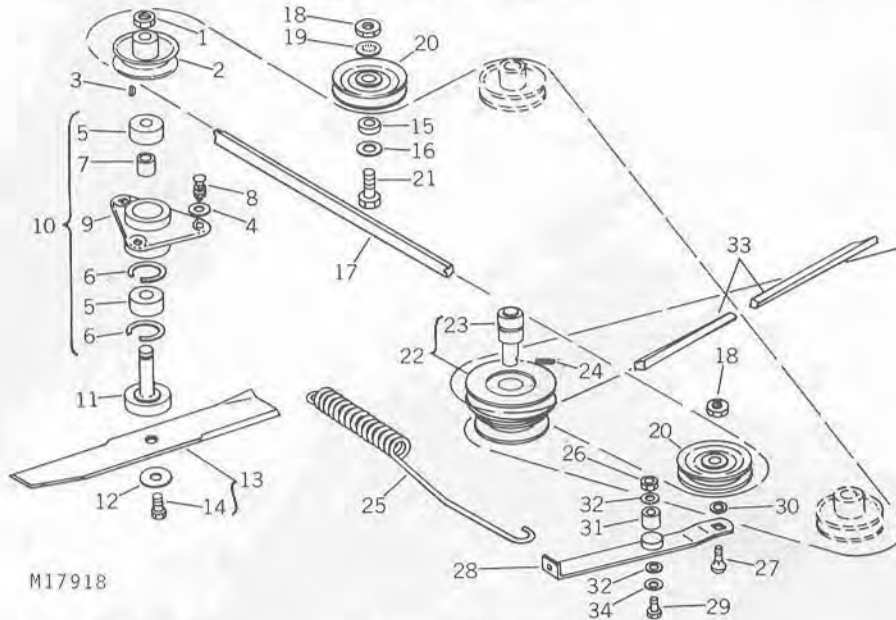

M17918

Key	Part No.	Serial No.	Description
1	P 48362	(-)	Nut, lock, 3/4" (3 used)
2	M 41628	(-)	Sheave, driven (4" [10.16 cm] O.D.) (3 used) (39 Mower)
	AM 31004	(-)	Sheave, driven (4-1/2" [11.43 cm] O.D.) (3 used) (47 Mower)
3	26H 14	(-)	Key, Woodruff, 3/16" x 3/4" (3 used)
4	24H 1294	(-)	Washer, 11/32" x 1-1/8" x 0.060" (9 used)
5	JD 9296	(-)	Bearing, ball (6 used)
6	J 2376 M	(-)	Ring, snap (6 used)
7	M 40636	(-)	Spacer, hub, center (3 used)
8	3H 2126	(-)	Bolt, cge., 5/16" x 1" (9 used)
	14H 785	(-)	Nut, 5/16" (9 used)
	12H 303	(-)	Washer, lock, 5/16" (9 used)
9	M 11031	(-)	Hub, flange (3 used)
10	AM 30302	(-)	Hub, flange, with bearings and snap rings assembled (3 used)
11	AM 30301	(-)	Spindle, blade (3 used) (sub. AM33098)
12	M 40634	(-)	Washer, drive (3 used)
13	AM 30698	(-)	Blade, cutting, with cap screw (3 used) (39 Mower)
	AM 31100	(-)	Blade, cutting, with cap screw (3 used) (47 Mower)
14	19H 1822	(-)	Screw, cap, 7/16" x 1" (3 used)
15	M 40509	(-)	Spacer, idler
16	24H 1351	(-)	Washer, 9/16" x 1-1/2" x 0.164" (2 used)
17	M 40223	(-)	V-belt, drive, deck (39 Mower)
	M 41960	(-)	V-belt, drive, deck (47 Mower)
18	14H 826	(-)	Nut, jam, 1/2" (2 used)
19	12H 292	(-)	Washer, internal-tooth, 1/2"
20	AM 30194	(-)	Sheave, idler (2 used) (sub. AM35862)
21	19H 1777	(-)	Screw, cap, 1/2" x 1-3/4"
22	AM 31373	(-)	Sheave, jack, with bearing assembled (5-1/2" [13.97 cm] O.D.) (39 Mower)
	AM 31384	(-)	Sheave, jack, with bearing assembled (6" [15.24 cm] O.D.) (47 Mower)
23	M 42786	(-)	Bearing, jack sheave
24	34H 284	(-)	Pin, spring, 3/16" x 1-1/4"
25	M 44810	(-)	Spring, idler (sub. for M41101 or M44086)
26	14H 812	(-)	Nut, 3/8"
27	3H 2307	(-)	Bolt, cge., 1/2" x 1-1/8"
28	AM 31374	(-)	Arm, idler
29	19H 1800	(-)	Screw, cap, 3/8" x 1-1/2"
30	12H 301	(-)	Washer, lock, 1/2"
31	M 41966	(-)	Spacer, idler arm, bronze
32	24H 1187	(-)	Washer, 25/64" x 7/8" x 0.075"
33	M 45998	(- 176558)	V-belt, drive, primary (39 Mower)
	M 47043	(176559 - 212088)	V-belt, drive, primary (39 Mower)
	M 47766 *	(212089 -)	V-belt, drive, primary (39 Mower)
	M 45998	(- 205468)	V-belt, drive, primary (sub. for M43693 and M42779) (47 Mower)
	M 47765	(205469 -)	V-belt, drive, primary (47 Mower)
34	24H 1176	(-)	Washer, 13/32" x 1-1/4" x 0.090"

*See Key 2, page 2.

DRAFT PLATE AND LIFT STRAPS

39 and 47 Mowers on 110-112 Tractors (SN100,001-) and 200, 210, 212 and 214 Tractors

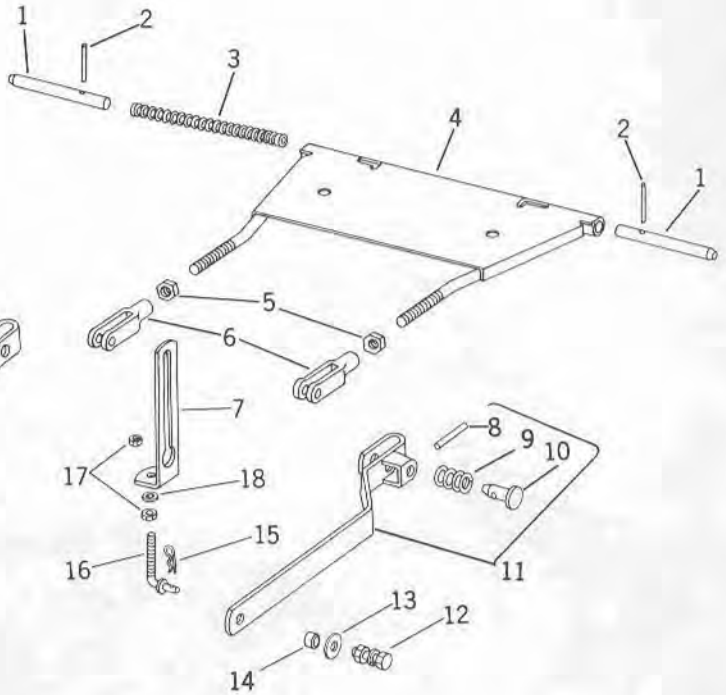
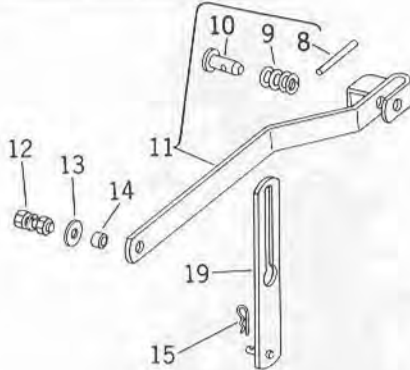
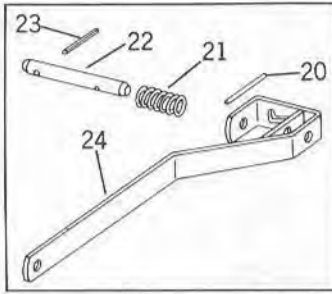

M17168

Key	Part No.	Serial No.	Description
1	M 42788	(-)	Pin, draft, front (2 used)
2	34H 316	(-)	Pin, spring, 1/4" x 1-1/2" (2 used)
3	M 42809	(-)	Spring
4	AM 31376	(-176558)	Plate, draft, front (39 Mower)
	AM 31387 *	(176559 -)	Plate, draft, front (39 Mower)
	AM 31387	(-)	Plate, draft, front (47 Mower)
5	14H 856	(-)	Nut, jam, 1/2" (2 used)
6	M 40211	(-)	Yoke, adjusting (2 used)
7	M 42792	(-)	Strap, lift, R.H.
8	34H 316 †	(see - below)	Pin, spring, 1/4" x 1-1/2" (2 used)
9	M 42578 †	(see - below)	Spring (2 used)
10	M 42579 †	(see - below)	Pin, coupler (2 used)
11	AM 34049 *	(176559 -)	Arm, draft, rear (39 Mower) (2 used)
	AM 34051	(142027 -)	Arm, draft, rear (47 Mower) (2 used)
12	19H 1731	(-)	Screw, cap, 3/8" x 1" (2 used)
	14H 812	(-)	Nut, 3/8"
	12H 304	(-)	Washer, lock, 3/8"
13	24H 1176	(-)	Washer, 13/32" x 1-1/4" x .090" (2 used)
14	M 40463	(-)	Bushing (2 used)
15	J 16931	(-)	Pin, spring locking (2 used)
16	M 42254	(-)	Rod, adjusting
17	14H 774	(-)	Nut, jam, 3/8" (2 used)
18	12H 304	(-)	Washer, lock, 3/8"
19	AM 31379	(-)	Strap, lift, L.H.
20	34H 388 †	(see - below)	Pin, spring, 5/32" x 2-1/4" (2 used)
21	R 26079 †	(see - below)	Spring (2 used)
22	M 42791 †	(see - below)	Pin, draft, rear (2 used)
23	34H 386 †	(see - below)	Pin, spring, 1/4" x 2" (2 used)
24	AM 31380	(-176558)	Arm, draft, rear (39 Mower) (2 used)
	AM 31389	(-142026)	Arm, draft, rear (47 Mower) (2 used)

* See Key 2, Page 2

† 39 Mower serial number (176559-)
 47 Mower serial number (142027-)

+ 39 Mower serial number (-176558)
 47 Mower serial number (-142026)

DRAFT PLATES AND LIFT STRAPS
39 and 47 Mowers on 110-112 Tractors (SN - 100,000)

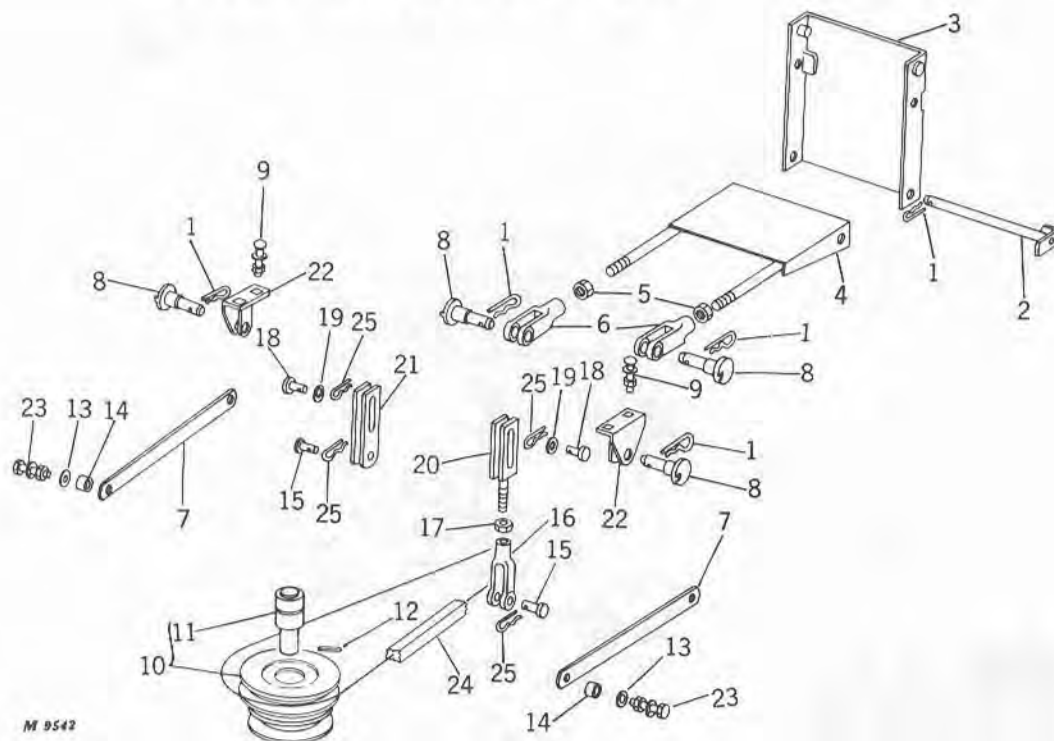

Key	Part No.	Serial No.	Description
1	M 40461	(-)	Pin, spring locking (5 used)
2	AM 30314	(-)	Pin, draft, welded
3	AM 30103	(-)	Plate, draft, front
4	AM 30102	(-)	Arm, draft, front (39 Mower)
	AM 31007	(-)	Arm, draft, front (47 Mower)
5	14H 856	(-)	Nut, jam, hex., 1/2" (2 used)
6	M 40211	(-)	Yoke, adjusting (2 used)
7	M 40639	(-)	Arm, draft, rear (2 used) (39 Mower)
	M 42262	(-)	Arm, draft (13-5/8" long) (2 used) (47 Mower)
8	M 41100	(-)	Pin, draft (4 used) (sub. for AM30110)
9	3H 1268	(-)	Bolt, cge., 5/16" x 3/4" (4 used)
	14H 785	(-)	Nut, 5/16" (4 used)
	12H 303	(-)	Washer, lock, 5/16" (4 used)
10	AM 31469	(-)	Sheave, jack, with bearing (4-1/8" [10.46 cm] O.D.) (39 Mower)
	AM 31427	(-)	Sheave, jack, with bearing (4-1/8" [10.46 cm] O.D.) (47 Mower)
11	M 42786	(-)	Bearing, jack sheave
12	34H 283	(-)	Pin, spring, 3/16" x 1-1/4"
13	24H 1308	(-)	Washer, 13/32" x 1" x 0.134" (2 used)
14	M 40463	(-)	Bushing (2 used)
15	M 40753	(-)	Pin, drilled, 3/8" x 1-1/4"
16	L 324 T	(-)	Yoke, adjusting (sub. for M42228)
17	14H 778	(-)	Nut, jam, hex., 3/8"
18	M 40569	(-)	Pin, drilled, 3/8" x 1" (3 used)
19	24H 1305	(-)	Washer, 25/64" x 7/8" x 0.060" (4 used)
20	AM 30126	(-)	Strap, lift, adjustable, R.H.
21	AM 30101	(-)	Strap, lift, L.H.
22	AM 30100	(-)	Bracket, draft, rear (2 used)
23	19H 1731	(-)	Screw, cap, 3/8" x 1" (2 used)
	14H 812	(-)	Nut, 3/8" (2 used)
	12H 304	(-)	Washer, lock, 3/8" (2 used)
24	M 40224	(-)	V-belt, drive (39 Mower)
	M 42261	(-)	V-belt, drive (47 Mower)
25	J 16931	(-)	Pin, spring locking (4 used)

DECALS



M12357

Key	Part No.	Serial No.	Description
1	M 45845	(-)	Decal, "Caution" (sub. for M40341 and M44102)
2A	M 44103	(- 190000)	Decal, "Width of Cut" (sub. for M40532)
2B	M 47280	(190001 -)	Decal, "Width of Cut"
3	JD 5274	(-)	Decal "Leaping Deer", 4" (sub. for JD262, JD5252, JD5253, JD5303 and JD5331)
4	M 45847	(-)	Decal, "Rotating Blades" (sub. for M41325 and M44106)
5	M 44107	(190001 -)	Decal, "Belt Installation"
..	AM 35074	(-)	Kit, French and English decal

ANTI-WRAP GUARD

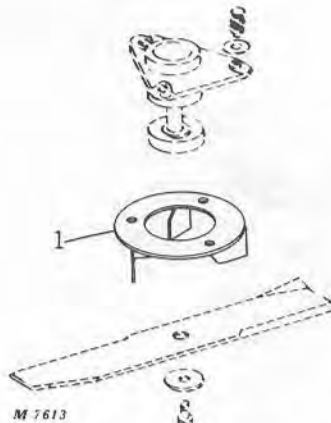

Key	Part No.	Serial No.	Description
1	AM 32179	(-)	Guard, anti-wrap

