

# **130, 160, 165, 175, 180, and 185 Lawn Tractors**

## **TECHNICAL MANUAL**

**John Deere  
Lawn & Grounds Care Division**

**TM1351 (Apr-88)**

# Introduction

## FOREWORD

This manual is written for an experienced technician. Essential tools required in performing certain service work are identified in this manual and are recommended for use.

Live with safety: Read the safety messages in the introduction of this manual and the cautions presented throughout the text of the manual.



This is the safety-alert symbol. When you see this symbol on the machine or in this manual, be alert to the potential for personal injury.

Technical manuals are divided in two parts: repair and diagnostics. Repair sections tell how to repair the components. Diagnostic sections help you identify the majority of routine failures quickly.

Information is organized in groups for the various components requiring service instruction. At the beginning of each group are summary listings of all applicable essential tools, service equipment and tools, other materials needed to do the job, service parts kits, specifications, wear tolerances, and torque values.

Binders, binder labels, and tab sets can be ordered by John Deere dealers direct from the John Deere Distribution Service Center.

This manual is part of a total product support program.

## FOS MANUALS—REFERENCE

### TECHNICAL MANUALS—MACHINE SERVICE

### COMPONENT MANUALS—COMPONENT SERVICE

Fundamentals of Service (FOS) Manuals cover basic theory of operation, fundamentals of troubleshooting, general maintenance, and basic type of failures and their causes. FOS Manuals are for training new personnel and for reference by experienced technicians.

Technical Manuals are concise guides for specific machines. Technical manuals are on-the-job guides containing only the vital information needed for diagnosis, analysis, testing, and repair.

Component Technical Manuals are concise service guides for specific components. Component technical manuals are written as stand-alone manuals covering multiple machine applications.

# Contents

## SECTION 10—General Information

- Group 05—Safety
- Group 10—General Specifications
- Group 15—Cap Screw Torque
- Group 20—Tune-Up
- Group 25—Fuel and Lubrication
- Group 30—Serial Numbers

## SECTION 20—Engine

- Group 05—Remove and Install
- Group 10—Muffler

## SECTION 30—Fuel and Air System

- Group 05—Fuel Pump and Fuel Tank

## SECTION 40—Electrical

- Group 05—Electric PTO Clutch

## SECTION 50—Power Train

- Group 05—Powered Wheels
- Group 10—Traction Drive Clutch
- Group 15—5-Speed Transaxle
- Group 20—Hydrostatic Transmission—Eaton
- Group 21—Hydrostatic Transmission—Sundstrand
- Group 25—Hydrostatic Differential—Peerless
- Group 26—hydrostatic Differential—Kanzaki

## SECTION 60—Steering and Brakes

- Group 05—Steering System
- Group 10—Front Axle
- Group 15—Brakes and Linkages

## Contents

## SECTION 80—MISCELLANEOUS

- Group 05—Mower Spindles
- Group 10—Mower Lift Linkage

## SECTION 210—SPECIFICATIONS/OPERATIONAL CHECKOUT PROCEDURE

- Group 01—Test and Adjustment
- Group 05—Machine Operational Checkout

*All information, illustrations and specifications in this manual are based on the latest information available at the time of publication. The right is reserved to make changes at any time without notice.*

TM1351-19-18APR90

## SECTION 220—ENGINE/FUEL OPERATION AND TESTS

- Group 05—Engine System Checkout
- Group 10—Engine System Diagnosis

## SECTION 240—ELECTRICAL OPERATION AND TESTS

- Group 05—Electrical System Checkout
- Group 10—Electrical System Diagnosis
- Group 15—Electrical System Component Tests
- Group 20—Theory of Operation

## SECTION 250—POWER TRAIN OPERATION AND TESTS

- Group 05—Hydrostatic Power Train System Checkout
- Group 06—Gear Power Train System Checkout
- Group 10—Hydrostatic Power Train System Diagnosis
- Group 11—Gear Power Train System Diagnosis
- Group 15—Hydrostatic Power Train
- Group 16—Gear Drive Power Train

## Index

COPYRIGHT© 1990  
DEERE & COMPANY  
Moline, Illinois  
All rights reserved

A John Deere ILLUSTRATION™ Manual  
Previous Editions  
Copyright 1989, 1988, 1987, 1986 Deere & Company

Contents

10

20

30

40

50

60

80

210

220

240

250

INDX

250

INDX

## TO JOHN DEERE DEALERS

### FILING INSTRUCTIONS

TM-1351 (APR-88)  
130, 160, 165, 175, 180, and 185 Lawn Tractors

Discard TM-1351 dated (Feb-87) and replace with this manual dated (Apr-88).

New information added to this manual includes:

- All repair specifications moved to Section 10, Group 10
- All test and adjustments specifications moved to Section 210, Group 01
- Sunstrand hydrostatic transmission repair and adjustment.
- Kanzaki differential repair
- Engine symptom/problem diagnostic charts in Section 220, Group 10
- New wiring schematic for new ground system.

The following service information bulletins apply to the 130, 160, 165, 175, 180 and 185 tractors:

TY87-70-6	M87-12-6
TY87-70-1	M87-12-5
M87-12-11	M87-12-4
M87-12-10	M87-12-3
M87-12-9	M87-12-2
M87-12-8	M87-12-1

MX,DEALER -19-07JUN89





# Section 10 General Information

## Contents

### Page

**Group 05—Safety** . . . . . 10-05-1

**Group 10—General Specifications**

Repair Specifications . . . . . 10-10-1

Tractor Specifications . . . . . 10-10-3

Mower Specifications . . . . . 10-10-4

**Group 15—Cap Screw Torque**

Inch Series Torque Chart . . . . . 10-15-1

Metric Series torque Chart . . . . . 10-15-2

**Group 20—Tune-Up**

Specifications . . . . . 10-20-1

Adjustments . . . . . 10-20-1

**Group 25—Fuel and Lubrication**

Fuel . . . . . 10-25-1

Engine Oil . . . . . 10-25-2

Peerless Differential Oil . . . . . 10-25-2

Kanzaki Differential Oil . . . . . 10-25-3

Eaton Hydrostatic Transmission Oil . . . . . 10-25-3

Substrand Hydrostatic Transmission Oil . . . . . 10-25-3

General Purpose grease . . . . . 10-25-4

**Group 30—Serial Numbers**

Product Identification Numbers . . . . . 10-30-1

Engine Serial Number . . . . . 10-30-1



## RECOGNIZE SAFETY INFORMATION

This is the safety-alert symbol. When you see this symbol on your machine or in this manual, be alert to the potential for personal injury.

Follow recommended precautions and safe operating practices.



O53,ALERT -19-16JUN87

10  
05  
1  
-UN-07DEC88  
T81389

## UNDERSTAND SIGNAL WORDS

A signal word—DANGER, WARNING, or CAUTION—is used with the safety-alert symbol. DANGER identifies the most serious hazards.

Safety signs with signal word DANGER or WARNING are typically near specific hazards.

General precautions are listed on CAUTION safety signs. CAUTION also calls attention to safety messages in this manual.



O53,SIGNAL -19-07OCT85

-19-30SEP88  
TS187

## HANDLE FUEL SAFELY—AVOID FIRES

Handle fuel with care: it is highly flammable. Do not refuel the machine while smoking or when near open flame or sparks.

Always stop engine before refueling machine. Fill fuel tank outdoors.

Prevent fires by keeping machine clean of accumulated trash, grease, and debris. Always clean up spilled fuel.



O53,FIRE1 -19-23APR87

-UN-23AUG88  
TS202

## WEAR PROTECTIVE CLOTHING

Wear close fitting clothing and safety equipment appropriate to the job.

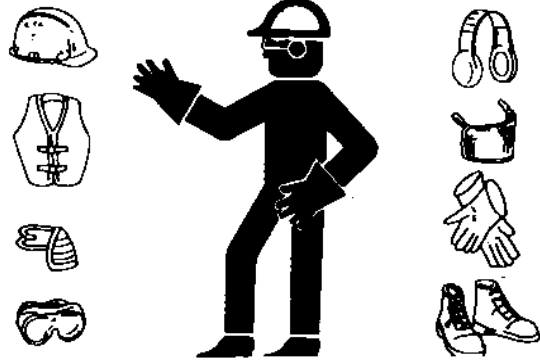

O53,WEAR2 -19-23APR87

TS206 -UN-23AUG88

## PROTECT AGAINST NOISE

Prolonged exposure to loud noise can cause impairment or loss of hearing.

Wear a suitable hearing protective device such as earmuffs or earplugs to protect against objectionable or uncomfortable loud noises.



O53,NOISE -19-23APR87

TS207 -UN-23AUG88

## PRACTICE SAFE MAINTENANCE

Understand service procedure before doing work. Keep area clean and dry.

Never lubricate or service machine while it is moving. Keep hands, feet, and clothing from power-driven parts. Disengage all power and operate controls to relieve pressure. Lower equipment to the ground. Stop the engine. Remove the key. Allow machine to cool.

Securely support any machine elements that must be raised for service work.

Keep all parts in good condition and properly installed. Fix damage immediately. Replace worn or broken parts. Remove any buildup of grease, oil, or debris.

Disconnect battery ground cable (-) before making adjustments on electrical systems or welding on machine.



O53,SERV -19-21DEC87

TS218 -UN-23AUG88

## AVOID HIGH-PRESSURE FLUIDS

Escaping fluid under pressure can penetrate the skin causing serious injury.

Avoid the hazard by relieving pressure before disconnecting hydraulic or other lines. Tighten all connections before applying pressure.

Search for leaks with a piece of cardboard. Protect hands and body from high pressure fluids.

If an accident occurs, see a doctor immediately. Any fluid injected into the skin must be surgically removed within a few hours or gangrene may result. Doctors unfamiliar with this type of injury may call the Deere & Company Medical Department in Moline, Illinois, or other knowledgeable medical source.

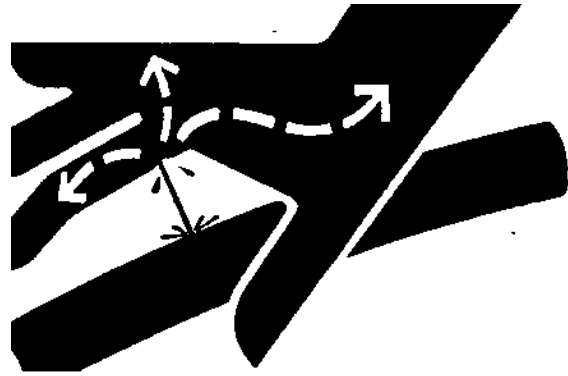

O53,FLUID -19-01DEC88

X9811 -UN-23AUG88

10  
305



**REPAIR SPECIFICATIONS**

**SECTION 20—Engine**

Item	Specification
PTO Mounting Cap Screw Torque . . . . .	56 N·m (45 lb-ft)

**SECTION 40—Electric PTO Clutch**

Item	Specification
PTO Clutch Clearance . . . . .	0.41 mm (0.016 in.)

**SECTION 50—Power Train**

Item	Specification
Powered Wheels	
Wheel Hub-to-Axle Housing Clearance . . . . .	0.25—1.02 mm (0.010—0.040 in.)
Traction Drive Clutch	
Belt Clearance . . . . .	94 mm (3.70 in.)
Belt Guide Clearance . . . . .	5 mm (0.20 in.)
5-Speed Transaxle	
Needle Bearings	
Output Pinion and Input Shaft Depth . . . . .	3.43—3.81 mm (0.135—0.150 in.)
Transaxle Cover Cap Screw Torque . . . . .	12 N·m (100 lb-in.)
Hydrostatic Transmission	
Eaton	
Dump Valve Shaft Torque . . . . .	3 N·m (30 lb-in.)
Body-to-Cover Cap Screw Torque . . . . .	20 N·m (180 lb-in.)
Oil Reservoir Torque . . . . .	14 N·m (124 lb-in.)
Control Arm Clearance . . . . .	0.70—2.50 mm (0.028—0.098 in.)
Control Lever Spring Length . . . . .	42 mm (1.700 in.)
Sundstrand	
Center Section-to-Transmission Cap Screw Torque . . . . .	17 N·m (150 lb-in.)
Drain Plug Torque . . . . .	15 N·m (130 lb-in.)
Transmission Oil Capacity . . . . .	850 cc (28.7 fl oz)
Hydrostatic Differential	
Peerless	
Ring Gear Cap Screw Torque . . . . .	10 N·m (88 lb-in.)
Differential Cover Cap Screw Torque . . . . .	11 N·m (97 lb-in.)
Differential Carrier-to-Case Thrust Surface Maximum Wear . . . . .	1.02 mm (0.040 in.)

M21,1010S,A1 -19-13MAY88

SECTION 50—Power Train (cont'd)

Item	Specification
Hydrostatic Differential (cont'd)	
Kanzaki	
Idle Gear I.D. . . . .	21.01—21.03 mm (0.827—0.828 in.)
Idler Shaft O.D. . . . .	16.99—17.00 mm (0.668—0.669 in.)
Cam Lever Shaft O.D. . . . .	19.97—20.03 mm (0.786—0.788 in.)
Cam Lever Shaft Bore I.D. (Cover) . . . . .	20.10—20.20 mm (0.791—0.795 in.)
Cam Lever Shaft Bore I.D. (Housing) . . . . .	20.05—20.08 mm (0.789—0.790 in.)
Actuator Thickness (Includes Ball) . . . . .	9.10—9.30 mm (0.358—0.366 in.)
Disc Thickness . . . . .	1.90—2.10 mm (0.075—0.083 in.)
Plate Thickness . . . . .	2.40—2.60 mm (0.094—0.102 in.)
Axle Housing (Needle Bearing) O.D. . . . .	24.98—25.00 mm (0.983—0.984 in.)
Counter Gear I.D. . . . .	20.01—20.03 mm (0.788—0.789 in.)
Pinion Drive O.D. . . . .	20.00—20.02 mm (0.787—0.788 in.)
Pinion Shaft O.D. . . . .	13.97—13.98 mm (0.549—0.550 in.)
Pinion Gear I.D. . . . .	14.03—14.05 mm (0.552—0.553 in.)
Differential Case (Axle End) I.D. . . . .	20.08—20.10 mm (0.790—0.791 in.)
Ring Gear Cap Screw Torque . . . . .	26 N·m (230 lb-in.)
Bearing Retainer Tapping Bolts	
New Case Torque . . . . .	29 N·m (22 lb-ft)
Used Case Torque . . . . .	25 N·m (221 lb-in.)
Axle Tapping Bolts	
New Case Torque . . . . .	29 N·m (22 lb-ft)
Used Case Torque . . . . .	25 N·m (221 lb-in.)
Ring Gear-to-Pinion Drive Gear Backlash . . . . .	0.15—0.30 mm (0.006—0.012 in.)
Cam Lever Shaft Tapping Bolt	
New Case Torque . . . . .	29 N·m (22 lb-ft)
Used Case Torque . . . . .	25 N·m (221 lb-in.)
Case Cover Tapping Bolts	
New Case Torque . . . . .	29 N·m (22 lb-ft)
Used Case Torque . . . . .	25 N·m (221 lb-in.)
Drain Plug Torque . . . . .	15 N·m (130 lb-in.)

SECTION 60—Steering and Brakes

Item	Specification
Brake Disk Gap Clearance . . . . .	0.50 mm (0.020 in.)

SECTION 80—Miscellaneous

Item	Specification
Mower Spindle	
Maximum Mower Spindle Rolling Torque . . . . .	0.07 N·m (0.60 lb-in.)
Spindle Mounting Bolt Torque . . . . .	25 N·m (221 lb-in.)
Mower Blade Cap Screw Torque . . . . .	75 N·m (55 lb-ft)
Mower Drive Sheave Nut Torque . . . . .	125 N·m (92 lb-ft)



## TRACTOR SPECIFICATIONS

### ENGINE

Manufacture	KAWASAKI
Engine Model Number	
130	FC290V
160/165	FB460V
175	FC420V
180/185	FC540V
Horsepower	
130	9
160/165	12.5
175	14
180/185	17
Cylinders	One
Cycle	Four
Speeds	
Full throttle, no load	3350 ± 100 rpm
Slow idle, no load	1400 ± 100 rpm
Spark Plug Type	
130	Champion RN11YC
160/165	Champion RCJ8 NGK-BMR4A
175	Champion RN11YC
180/185	Champion RN11YC
Spark Plug Gap	
130, 175, 180/185	0.70—0.80 mm (0.028—0.031 in.)
160/165	0.60—0.70 mm (0.024—0.028 in.)

### ELECTRICAL SYSTEM

Battery, John Deere (TY6109)	12 Volt
255 amp cold cranking capacity capacity at 25 amp	
Alternator Charging Capacity	
130	13 Amp
160/165	13 Amp
175	13 Amp
180/185	15 Amp
Ignition	Solid State

### CAPACITIES

Fuel Tank	8.3 L (2.2 gal)
Engine Oil, Without Filter	
130	1.1 L (2.3 pt)
160/165	1.4 L (3 pt)
175	1.3 L (2.7 pt)
180/185	1.6 L (3.4 pt)
Engine Oil, With Filter	
160/165	1.6 L (3.4 pt)
175	1.7 L (3.6 pt)
180/185	2.0 L (4.2 pt)
Transaxle	
130/160/180	1.1 L (2.3 pt)
Hydrostatic Transmission	
165/175/185	0.7 L (1.5 pt)
Differential	
165/175/185	0.7 L (1.5 pt)

### TRAVEL SPEEDS AT 3300 RPM

First Gear-Transaxle	
130/160/180	2.2 km/h (1.4 mph)
180 w/46 in. Mower	2.4 km/h (1.5 mph)
Second Gear	
130/160/180	3.5 km/h (2.2 mph)
180 w/46 in. Mower	3.8 km/h (2.4 mph)
Third Gear	
130/160/180	5.3 km/h (3.3 mph)
180 w/46 in. Mower	5.6 km/h (3.5 mph)
Fourth Gear	
130/160/180	6.7 km/h (4.2 mph)
180 w/46 in. Mower	7.2 km/h (4.5 mph)
Fifth Gear	
130/160/180	7.8 km/h (4.9 mph)
180 w/46 in. Mower	8.5 km/h (5.3 mph)
Hydrostatic Transmission	
Forward	0-8 km/h (0-5 mph)
Reverse	0-4 km/h (0-2.5 mph)

### APPROXIMATE WEIGHT

130	184 kg (405 lb)
160	202 kg (445 lb)
165 and 175	213 kg (470 lb)
180 with 30 in. Mower	220 kg (485 lb)
180 with 46 in. Mower	236 kg (520 lb)
180 with 38 in. Mower	231 kg (510 lb)

M21,1010S,A3 -19-16MAY88

10  
10  
3

**MOWER SPECIFICATIONS**

10  
10  
4

Item	30-Inch	38-Inch	46-Inch
Type	Rotary	Rotary	Rotary
Cutting Blades	One	Two	Three
Blade Length	762 mm (30 in.)	496 mm (19.50 in.)	407 mm (16 in.)
Cutting Width	762 mm (30 in.)	965 mm (38 in.)	1170 mm (46 in.)
Cutting Height	25.40—102 mm (1.00—4.00 in.)	25.40—102 mm (1.00—4.00 in.)	38.10 . . . . . 102 mm (1.50—4.00 in.)

Specifications and design subject to change without notice.

M21,1010S,A4 -19-16MAY88

## CAP SCREW TORQUE VALUES

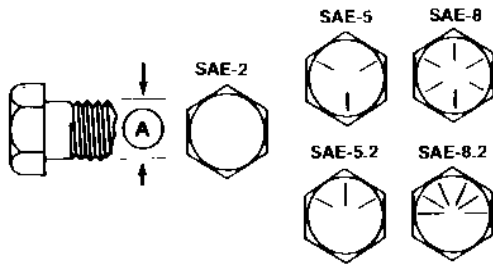

*Inch Cap Screw Head Markings*

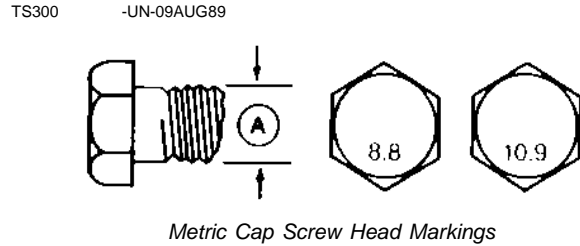

*Metric Cap Screw Head Markings*

### INCH CAP SCREW TORQUE VALUES

Bolt Diameter (A)	Wrench Size	Cap Screw Grade					
		SAE 2		SAE 5		SAE 8	
		N-m	lb-ft	N-m	lb-ft	N-m	lb-ft
1/4"	7/16"	7	(5)	11	(8)	16	(12)
5/16"	1/2"	14	(10)	23	(17)	33	(24)
3/8"	9/16"	24	(18)	41	(30)	54	(40)
7/16"	5/8"	41	(30)	68	(50)	95	(70)
1/2"	3/4"	61	(45)	102	(75)	142	(105)
9/16"	13/16"	88	(65)	142	(105)	203	(150)
5/8"	15/16"	122	(90)	197	(145)	278	(205)
3/4"	1-1/8"	217	(160)	353	(260)	495	(365)
7/8"	1-5/16"	224	(165)	563	(415)	800	(590)
1"	1-1/2"	332	(245)	848	(625)	1193	(880)
1-1/4"	1-7/8"	665	(490)	1492	(1100)	2393	(1765)

**CAUTION:** Use only metric tools on metric hardware. Other tools may not fit properly. They may slip and cause injury.

DO NOT use these values if a different torque value or tightening procedure is listed for a specific application. Torque values listed are for general use only. Check tightness of cap screws periodically.

Shear bolts are designed to fail under predetermined loads. Always replace shear bolts with identical grade.

### METRIC CAP SCREW TORQUE VALUES

Bolt Diameter (A)	Wrench Size	Markings on Cap Screw Heads			
		8.8		10.9	
		N-m	lb-ft	N-m	lb-ft
5 mm	8 mm	6	(4.5)	9	(6.5)
6 mm	10 mm	10	(7.5)	15	(11)
8 mm	13 mm	25	(18)	35	(26)
10 mm	16 mm	50	(37)	75	(55)
12 mm	18 mm	85	(63)	130	(97)
16 mm	24 mm	215	(159)	315	(232)
20 mm	30 mm	435	(312)	620	(457)
24 mm	36 mm	750	(553)	1070	(789)
30 mm	46 mm	1495	(1103)	2130	(1571)

Fasteners should be replaced with the same or higher grade. If higher grade fasteners are used, these should only be tightened to the strength of the original.

Make sure fastener threads are clean and you properly start thread engagement. This will prevent them from failing when tightening.

Tighten plastic insert or crimped steel-type lock nuts to approximately 50 percent of amount shown in chart. Tighten toothed or serrated-type lock nuts to full torque value.

METRIC SERIES TORQUE CHART

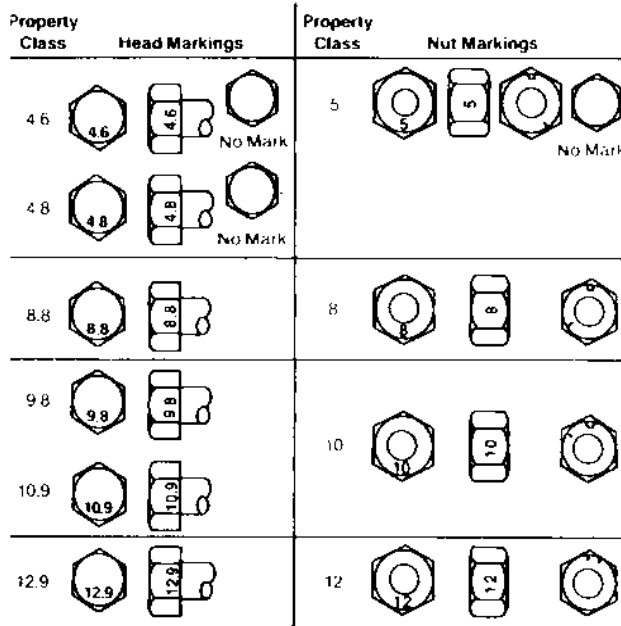

TS234 -19-19DEC88

**CAUTION:** Use only metric tools on metric hardware. Other tools may not fit properly. They may slip and cause injury.

Fasteners should be replaced with the same or higher grade. If higher grade fasteners are used, these should only be tightened to the strength of the original.

Check tightness of cap screws periodically. Torque values listed are for general use only. Do not use these values if a different torque value or tightening procedure is listed for a specific application.

Make sure fastener threads are clean and you properly start thread engagement. This will prevent them from failing when tightening.

Shear bolts are designed to fail under predetermined loads. Always replace shear bolts with identical grade.

Tighten cap screws having lock nuts to approximately 50 percent of amount shown in chart.

DIA.	WRENCH SIZE	4.6		4.8		8.8		9.8		10.9		12.9	
		OIL	DRY	OIL	DRY	OIL	DRY	OIL	DRY	OIL	DRY	OIL	DRY
		N-m(lb-ft)	N-m(lb-ft)	N-m(lb-ft)	N-m(lb-ft)	N-m(lb-ft)	N-m(lb-ft)	N-m(lb-in)	N-m(lb-in)	N-m(lb-ft)	N-m(lb-ft)	N-m(lb-ft)	N-m(lb-ft)
M5	8mm	1.5(1)	2.5(1.5)	2.5(1.5)	3.0(2)	4.5(3.5)	6.0(4.5)	5.0(3.5)	7.0(5)	6.5(4.5)	9.0(6.5)	7.5(5.5)	10.0(7.5)
M6	10mm	3.0(2)	4.0(3)	4.0(3)	5.5(4)	7.5(5.5)	10.0(7.5)	8.5(6)	12.0(9)	11.0(8)	15.0(11)	13.0(9.5)	18.0(13)
M8	13mm	7.0(5)	9.5(7)	10.0(7.5)	13.0(10)	18.0(13)	25(18)	21.0(15)	30(22)	25(18)	35(26)	30(22)	45(33)
M10	16mm	14.0(10)	19.0(14)	20.0(15)	25(18)	35(26)	50(37)	40(30)	55(41)	55(41)	75(55)	65(48)	85(63)
M12	18mm	25(18)	35(26)	35(26)	45(33)	65(48)	85(63)	70(52)	100(74)	95(70)	130(97)	110(81)	150(111)
M14	21mm	40(30)	50(37)	55(41)	75(55)	100(74)	140(103)	115(85)	155(114)	150(111)	205(151)	175(129)	240(177)
M16	24mm	60(44)	80(59)	85(63)	115(85)	160(118)	215(159)	180(133)	245(180)	235(173)	315(232)	275(203)	370(273)
M18	27mm	80(59)	110(81)	115(85)	160(118)	225(166)	305(225)			320(236)	435(321)	375(277)	510(376)
M20	30mm	115(85)	160(118)	165(122)	225(166)	320(236)	435(321)			455(356)	620(457)	535(395)	725(535)
M22	33mm	160(118)	215(159)	225(167)	305(225)	435(321)	500(435)			620(457)	840(620)	725(535)	985(726)
M24	36mm	200(148)	275(203)	285(210)	390(288)	555(409)	750(553)			790(583)	1070(789)	925(682)	1255(926)
M27	41mm	295(218)	400(295)	415(306)	565(417)	810(597)	1100(811)			1155(852)	1565(1154)	1350(996)	1835(1353)
M30	46mm	400(295)	545(402)	565(417)	770(568)	1100(811)	1495(1103)			1570(1158)	2130(1571)	1835(1353)	2490(1837)
M33	51mm	545(402)	740(546)	770(568)	1050(774)	1500(1106)	2035(1500)			2135(1575)	2900(2139)	2500(1840)	3390(2500)
M36	55mm	700(516)	950(700)	990(730)	1345(992)	1925(1420)	2610(1925)			2740(2021)	3720(2744)	3205(2364)	4355(3212)

-19-08MAY95

TM1351 (18APR90)

10-152

130 - 185 LAWN TRACTORS

**TUNE-UP SPECIFICATIONS**

Spark Plug Gap	
130, 175, 180/185 .....	0.70—0.80 mm (0.028—0.031 in.)
160/165 .....	0.60—0.70 mm (0.024—0.028 in.)
Spark Plug Torque .....	15 N·m (133 lb-in.)
Idle Speed .....	1400 rpm
High Speed .....	3350 rpm

M21,1020S,A2 -19-16MAY88

**TUNE-UP SPECIFICATIONS**

Perform tune-up adjustments in the following order to improve the efficiency and operation of the tractor.

Tune-Up Adjustment	Section	Group
1. Clean engine and cooling system.		
2. Clean air cleaner.		
3. Check or replace fuel filter.		
4. Check battery electrolyte level.		
5. Check spark.	220	10
6. Check spark plug.	220	10
7. Check compression.	220	10
8. Adjust carburetor and engine speeds.	220	10
9. Check crankcase breather.	CTM-5	
10. Check crankcase vacuum.	220	10
11. Check and adjust governor.	220	10
12. Check and adjust brakes.	60	15
13. Check and adjust hydrostatic control lever linkage.	250	10
14. Check hydrostatic control lever friction adjustment.	250	10
15. Adjust steering axle.	60	10
16. Check tire pressure.		05

M21,1020S,A1 -19-18APR88



## FUEL

 **CAUTION:** Handle fuel carefully. Always stop engine before refueling. Fill fuel tank outdoors. If engine is hot, let engine cool several minutes before you add fuel. Do not smoke while you fill the fuel tank or service the fuel system. Fill fuel tank only to bottom of filler neck.

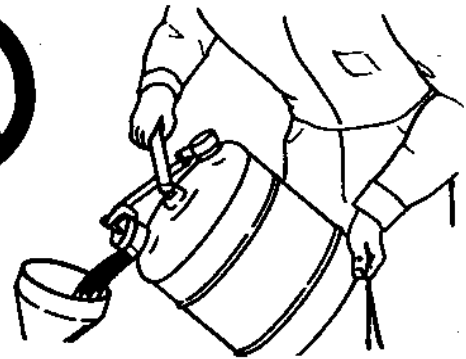

10  
25  
-UN-23AUG88  
TS185

**IMPORTANT: DO NOT** mix oil with gasoline.

Unleaded fuel is recommended. Regular leaded gasoline with an anti-knock index of 87 or higher may be used. Avoid switch from unleaded to regular gasoline to prevent engine damage.

Use of gasohol is acceptable as long as the ethyl alcohol blend does not exceed 10 per cent. Unleaded gasohol is preferred over leaded gasohol.

Fuel tank capacity is 2-1/2 gal (9.5 L).

Lift seat. Fill fuel tank at end of each day's operation. This helps to keep condensation out of fuel tank.

M21,FLS,A -19-03APR87

## GASOLINE ENGINE OIL

10  
25  
2

Use oil viscosity based on the expected air temperature range during the period between oil changes.

John Deere PLUS-4® engine oil is recommended.

Other oils may be used if they meet API Service Classification SF or SE.

Oils meeting Military Specification MIL-L-46167A may be used as arctic oils.

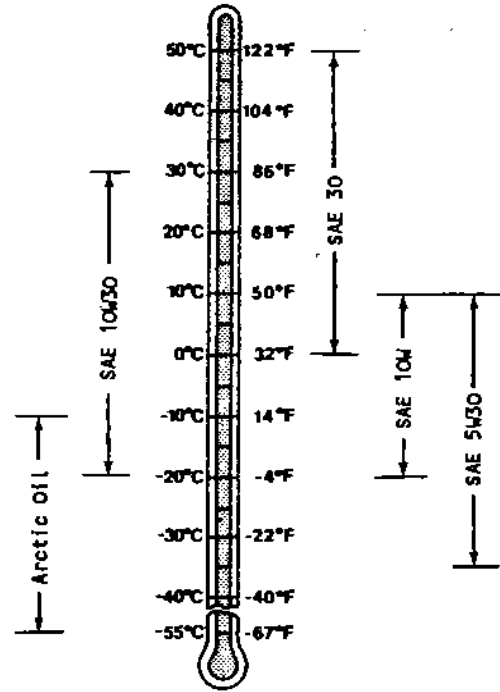

O53,GAS -19-05FEB88

TS239 -19-09NOV88

## PEERLESS DIFFERENTIAL OIL—ALL 165, 175 AND 185 (S.N. —475000)

Use oil viscosity as shown on the temperature chart for the expected air temperature range during the drain interval.

SAE 90 oil is recommended in the differential. Other oils shown in the chart can also be used. DO NOT mix oils of different viscosities.

**IMPORTANT: DO NOT put SAE 90 oil in the hydrostatic transmission.**

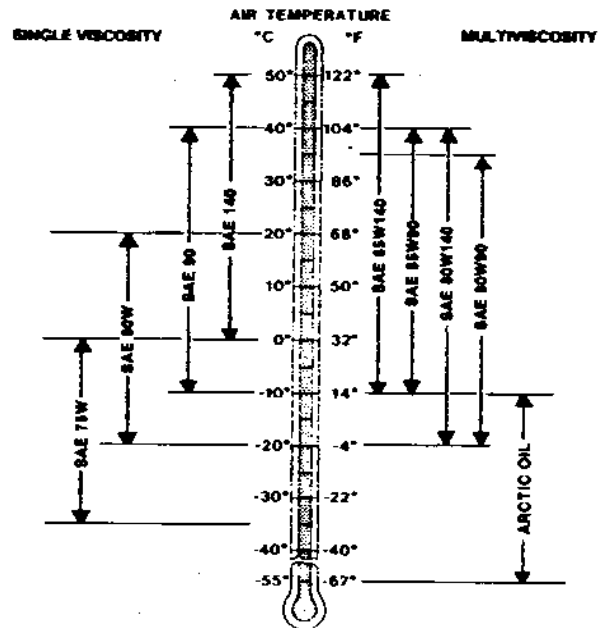

M21,1025S,A1 -19-13MAY88

X9322 -19-30SEP88



**KANZAKI DIFFERENTIAL OIL—185 (S.N. 475001— )**

SAE 10W30 engine oil with an API classification of SE, CC or CD is recommended in the differential. DO NOT mix oils of different viscosities.

**IMPORTANT: DO NOT put SAE 90 oil in the hydrostatic transmission or differential.**

M21,1025S,A2 -19-13MAY88

**EATON HYDROSTATIC TRANSMISSION OIL—ALL 165, 175 AND 185 (S.N. —475000)**

**IMPORTANT: DO NOT use type F automatic transmission fluid or any other type oil other than specified. Oil must be from a sealed plastic or all metal can to avoid any moisture.**

SAE 30 engine oil with an API classification of SE, CC or CD is recommended in the transmission. SAE 20 or 40 engine oil can also be used depending on temperature range during the service interval.

M21,1025S,A3 -19-13MAY88

**SUNDSTRAND HYDROSTATIC TRANSMISSION OIL—185 (S.N. 475001— )**

SAE 10W 30 engine oil with an API classification of SE, CC or CD is recommended in the transmission.

M21,1025S,A4 -19-13MAY88

## GENERAL PURPOSE GREASE

Use grease as shown on the temperature chart for the expected air temperature range during the service interval.

John Deere Multipurpose Grease is recommended. If other greases are used, use:

- SAE Multipurpose Grease.
- Multipurpose Grease containing 3 to 5 percent molybdenum disulfide.

At temperatures below  $-22^{\circ}\text{F}$  ( $-30^{\circ}\text{C}$ ), use arctic greases such as those meeting Military Specification MIL-G-10924C.

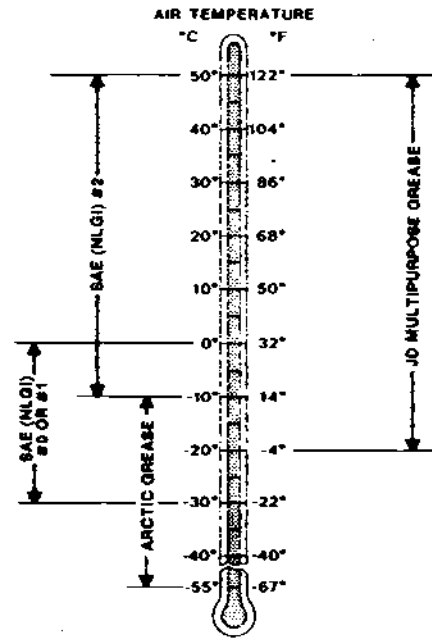

X9326 -19-30SEP88

M21,FLJ,05 -19-12MAY83

10  
25  
4

PRODUCT IDENTIFICATION NUMBER



M21,1030S,1 -19-13FEB86

10  
30  
-UN-29AUG88  
M38557

ENGINE SERIAL NUMBER



M21,1030S,2 -19-13FEB86

-UN-29AUG88  
M38600

*Serial Numbers/Engine Serial Number*

10  
30  
2

# Section 20 Engine

## Contents

### Page

#### Group 05—Remove and Install

Kawasaki Engine Repair—Use CTM-5 . . .	20-05-1
Other Materials . . . . .	20-05-1
Remove and Install Engine	
130 . . . . .	20-05-1
160 and 165 . . . . .	20-05-3
175, 180 and 185 . . . . .	20-05-6

#### Group 10—Muffler

Replace Muffler	
130 . . . . .	20-10-1
160 and 165 . . . . .	20-10-2
175, 180 and 185 . . . . .	20-10-3

20



**KAWASAKI ENGINE REPAIR—USE CTM-5**

For complete repair information the component technical manual (CTM) is also required.

Use the component manual in conjunction with this machine manual.



M21,2005S,A1 -19-18APR88

TS225

20  
05

**OTHER MATERIAL**

Number	Name	Use
PT569	NEVER-SEEZ® Lubricant	Lubricate crankshaft

*NEVER-SEEZ is a trademark of the Never-Seez Corp.*

M21,2005S,X -19-20JAN86

**REMOVE AND INSTALL ENGINE—130**

1. Remove hood, muffler and pedestal shroud.

**⚠ CAUTION: Gasoline is dangerous. Avoid fires due to smoking or careless maintenance practices.**

2. Close fuel shut-off valve. Disconnect fuel line.



M21,2005S,A2 -19-18APR88

M50205  
-UN-22DEC89

3. Loosen cap screw and disconnect throttle cable.



M21,2005S,A3 -19-18APR88

M50206  
-UN-22DEC89

Remove and Install/Remove and Install Engine

4. Disconnect two wires from ground terminal on right-hand side of engine.



M21,2005S,A4 -19-18APR88

M50207 -UN-22DEC89

5. Disconnect wire from starter.



M21,2005S,A5 -19-18APR88

M50208 -UN-22DEC89

6. Disconnect ignition wire (A) and remove wire from grommet (B).

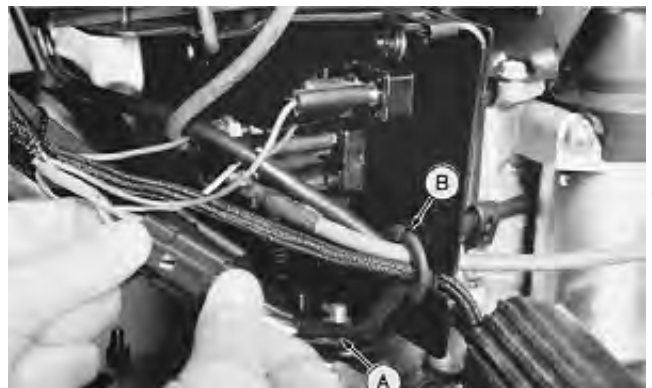

M21,2005S,A6 -19-18APR88

M50209 -UN-22DEC89

7. Remove electric PTO clutch. (See Section 40, Group 05.)

8. Depress clutch pedal and remove belt from idler wheel and drive sheave.

9. Remove drive sheave (A) and key (B).



M21,2005S,A7 -19-18APR88

M50210 -UN-22DEC89



## Remove and Install/Remove and Install Engine

10. Remove four engine mounting cap screws and belt guide (A).



M21,2005S,A8 -19-18APR88

M50211 -UN-22DEC89

30520

11. Rotate engine to clear oil drain from hole in frame and remove engine.

12. When installing engine, apply NEVER-SEEZE lubricant to crankshaft before installing drive sheave.

13. Tighten PTO clutch mounting cap screw to 56 N·m (45 lb-ft).

14. Adjust throttle cable, choke, governor, fast idle and slow idle. (See Section 220.)



M21,2005S,A9 -19-13MAY88

M50212 -UN-29JAN90

## REMOVE AND INSTALL ENGINE—160 AND 165

1. Remove hood, muffler and pedestal shroud.

**⚠ CAUTION: Gasoline is dangerous. Avoid fires due to smoking or careless maintenance practices.**

2. Close fuel shut-off valve. Disconnect fuel line.
3. Disconnect throttle cable (A).



M21,2005S,A10 -19-18APR88

M50220 -UN-22DEC89

Remove and Install/Remove and Install Engine

20  
05  
4

4. Disconnect two wires from ground terminal on right-hand side of engine.



M50221  
-UN-22DEC89

M21,2005S,A11 -19-18APR88

5. Disconnect wires (A and B). Remove wires from behind oil fill tube (C).



M50222  
-UN-22DEC89

M21,2005S,A12 -19-18APR88

6. Disconnect ignition wire (A) and remove wire from grommet (B).



M50223  
-UN-22DEC89

M21,2005S,A13 -19-18APR88

Remove and Install/Remove and Install Engine

7. Remove electric PTO clutch. (See Section 40, Group 05.)

8. Relieve tension in traction belt for hydrostatic tractors. For gear driven tractors, depress clutch pedal. Remove belt from idler wheel and drive sheave.

9. Remove drive sheave (A) and key (B).

Model 160 Shown



M50224 -UN-22DEC89

20

M21,2005S,A14 -19-18APR88

10. Remove four engine mounting cap screws. On gear driven tractors, remove belt guard (A).



M50194 -UN-22DEC89



M50225 -UN-22DEC89

M21,2005S,A15 -19-18APR88

## Remove and Install/Remove and Install Engine

11. Rotate engine to clear oil drain from hole in frame and remove engine.
12. When installing engine, apply NEVER-SEEZ lubricant to crankshaft before installing drive sheave.
13. Tighten PTO clutch mounting cap screw to 56 N·m (45 lb-ft).
14. Adjust throttle cable, choke, governor, fast idle and slow idle. (See Section 220.)



M21,2005S,A16 -19-13MAY88

M50226  
-UN-22DEC89

### REMOVE AND INSTALL ENGINE—175, 180 AND 185

1. Remove hood, muffler and pedestal shroud.

**⚠ CAUTION: Gasoline is dangerous. Avoid fires due to smoking or careless maintenance practices.**

2. Close fuel shut-off valve. Disconnect fuel line.

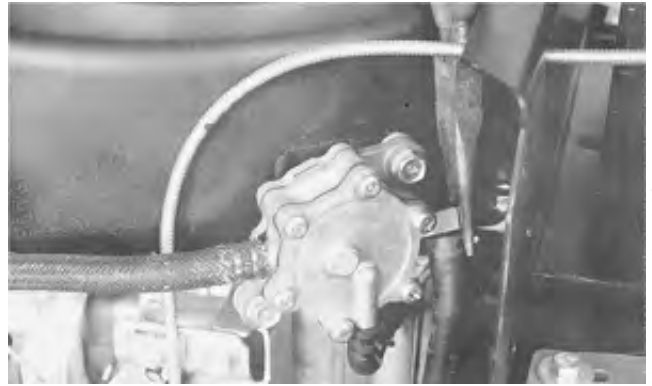

M21,2005S,A17 -19-18APR88

M50187  
-UN-22DEC89

3. Loosen cap screw and disconnect throttle cable.



M21,2005S,A18 -19-18APR88

M50188  
-UN-22DEC89

4. Disconnect two wires from ground terminal on right-hand side of engine.



M21,2005S,A19 -19-18APR88

M50189  
-UN-22DEC89

Remove and Install/Remove and Install Engine

5. Disconnect wires (A, B and C) from starter solenoid.

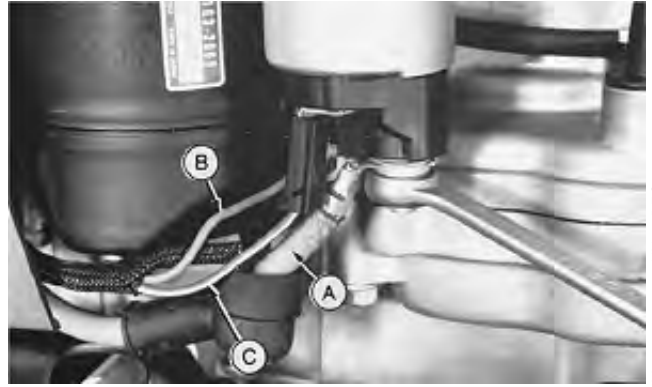

M21,2005S,A20 -19-18APR88

M50190 -UN-22DEC89

20  
05

6. Disconnect ignition wire (A) and remove wire from grommet (B).

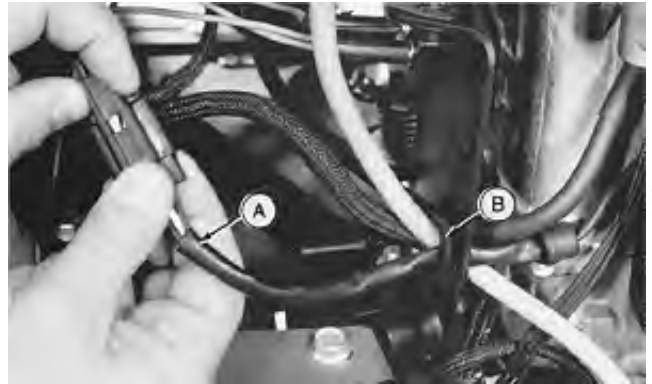

M21,2005S,A21 -19-18APR88

M50191 -UN-22DEC89

7. Remove electric PTO clutch. (See Section 40, Group 05.)

8. Relieve tension in traction belt for hydrostatic tractors. For gear driven tractors, depress clutch pedal. Remove belt from idler wheel and drive sheave.

9. Remove drive sheave (A) and key (B).



Model 185 Shown



M21,2005S,A22 -19-18APR88

M50192 -UN-22DEC89

M50193 -UN-22DEC89

10. Remove four engine mounting cap screws. On gear driven units, remove belt guard (A).



M50194 -UN-22DEC89



M50225 -UN-22DEC89

M21,2005S,A23 -19-18APR88

11. Rotate engine to clear oil drain from hole in frame and remove engine.

12. When installing engine, apply NEVER-SEEZ lubricant to crankshaft before installing drive sheave.

13. Tighten PTO clutch mounting cap screw to 56 N-m (45 lb-ft).

14. Adjust throttle cable, choke, governor, fast idle and slow idle. (See Section 220.)



M50195 -UN-22DEC89

M21,2005S,A24 -19-18APR88

### REPLACE MUFFLER—MODEL 130

1. Remove hood.
2. Remove four cap screws and remove air duct.



M50214  
-UN-22DEC89

M21,2020S,F -19-21DEC85

3. Disconnect spark plug wire.
4. Remove engine cover (A).



M50215  
-UN-22DEC89

M21,2020S,G -19-21DEC85

5. Remove two nuts and washers. Remove muffler.
6. Put muffler and gasket into position.
7. Install and tighten two washers and nuts.
8. Install cover (A).
9. Connect spark plug wire.
10. Install air duct.
11. Install hood.



M50216  
-UN-22DEC89

M21,2020S,H -19-21DEC85

## REPLACE MUFFLER—MODELS 160 AND 165

1. Remove hood.
2. Disconnect spark plug wire and remove rubber grommet to remove spark plug wire from air duct.



M50217  
-UN-22DEC89

M21,2020S,C -19-21DEC85

3. Remove four cap screws and two cap screws and nuts from air duct.
4. First, remove right side of air duct (A), then left side (B).



M50218  
-UN-22DEC89

M21,2020S,D -19-21DEC85

5. Remove four cap screws and two spacers and remove muffler.
6. Position muffler and gasket.
7. Install and tighten two spacers and four cap screws.
8. Install left side of air duct, then right side.
9. Put spark plug wire through hole in air duct and connect to plug. Install rubber grommet.
10. Install hood.



M50219  
-UN-22DEC89

M21,2020S,E -19-21DEC85



## REPLACE MUFFLER—MODELS 175, 180, AND 185

1. Remove hood.
2. Remove four cap screws and remove air duct.



M21,2020S,A -19-19DEC86

M50198 -UN-22DEC89

20  
10  
3

3. Remove two nuts, washers and two cap screws (A).
4. Pull out on muffler guard and remove muffler.
5. Position muffler and gasket by pulling out on muffler shield.
6. Install and tighten two cap screws (A), two nuts and washers.
7. Install air duct.
8. Install hood.



M21,2020S,B -19-13DEC85

M50197 -UN-22DEC89

*Muffler/Replace Muffler*

20  
10  
4

# Section 30 Fuel and Air System

## Contents

Page

### Group 05—Fuel Pump and Fuel Tank

Air Cleaner, Breather and Carburetor

Repair—Use CTM-5 . . . . . 30-05-1

Fuel Pump

Remove . . . . . 30-05-1

Service . . . . . 30-05-1

Fuel Tank

Remove . . . . . 30-05-3

Inspect . . . . . 30-05-4

Disassemble . . . . . 30-05-4

Assemble . . . . . 30-05-4

Install . . . . . 30-05-5

30



## AIR CLEANER, BREATHER AND CARBURETOR REPAIR—USE CTM-5

For complete repair information the component technical manual (CTM) is also required.

Use the component manual in conjunction with this machine manual.



M21,3005S,A1 -19-18APR88

TS225  
-UN-17JAN89

## REMOVE FUEL PUMP

**CAUTION:** Gasoline is dangerous. Avoid fires due to smoking or careless maintenance practices.

1. Test fuel pump before removal. (See Section 220.)
2. Disconnect vacuum line and fuel lines (A and B).
3. Remove fuel pump.

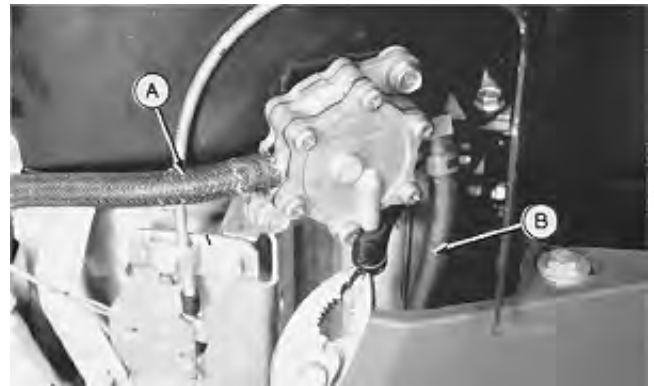

M21,3005S,A2 -19-18APR88

M50185  
-UN-22DEC89

## SERVICE FUEL PUMP

1. Remove screws and washers.
2. Remove cover, gaskets and diaphragm. Make sure vent in cover is not plugged. Inspect diaphragm for hairline cracks or wear.



M21,3005S,A3 -19-13MAY88

M50199  
-UN-31AUG88

3. Remove pump body and gasket (A).



M21,3005S,E -19-11DEC85

M50201  
-UN-31AUG88

## Fuel Pump and Fuel Tank/Fuel Pump

4. Remove valves by pulling rubber grommet. Inspect valves for hairline cracks or wear.



M21,3005S,F -19-11DEC85

M50202  
-UN-31AUG88

5. Remove bottom diaphragm and gasket. Inspect diaphragm for holes, wrinkles or wear.

6. Inspect all pump mounting surfaces. They must be free of any nicks or burrs. Replace any worn or damaged gaskets or diaphragms.



M21,3005S,G -19-11DEC85

M50203  
-UN-31AUG88

7. When installing inlet and outlet valve assemblies, use a punch or small dull shaft to stretch rubber grommet. Push stretched assembly into pump body.

8. When assembling pump body, be sure flat area on bottom plate and pump body match.



M21,3005S,A4 -19-18APR88

M50204  
-UN-31AUG88

## REMOVE FUEL TANK

1. Remove mower height knob, park brake knob (A) and transmission selector knob (B).

On hydrostatic tractors, remove tow valve knob (C).

2. Disconnect seat switch.

3. Remove pedestal shroud and platform.

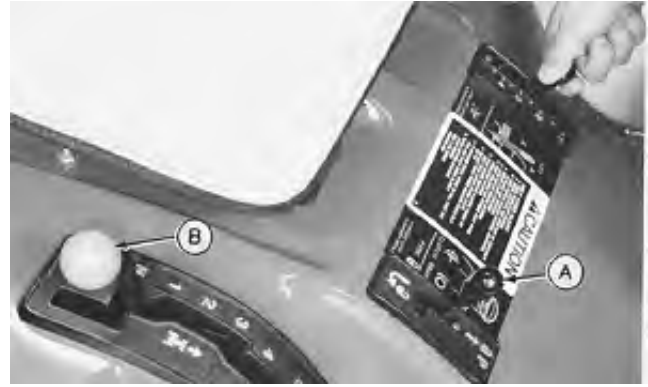

M50172 -UN-22DEC89



M50173 -UN-22DEC89

M21,3005S,A5 -19-18APR88



**CAUTION: Gasoline is dangerous. Avoid fires due to smoking or careless maintenance practices.**

4. Close shut-off valve. Disconnect fuel line and remove it from foam pad.



M50178 -UN-22DEC89

M21,3005S,A6 -19-18APR88

5. Disconnect fuel sensor wiring harness and remove it from foam pad.

6. Remove fuel tank.



M50179 -UN-22DEC89

M21,3005S,A7 -19-18APR88

## INSPECT FUEL TANK

1. Replace tank if damaged.
2. Check rubber bushings for leaks or damage. Replace if necessary. (See Disassemble Fuel Tank in this group.)
3. Make sure overflow tube (A) is not plugged.



M21,3005S,V -19-11DEC85

M50180 -UN-22DEC89

## DISASSEMBLE FUEL TANK

1. If equipped, pull fuel sensor from tank. Test fuel sensor. (See Section 240.)



M21,3005S,A8 -19-18APR88

M50181 -UN-22DEC89

2. Pull shut-off valve from tank.



M21,3005S,X -19-11DEC85

M50182 -UN-22DEC89

## ASSEMBLE FUEL TANK

1. Push rubber bushing into tank.
2. Push shut-off valve into housing.



M21,3005S,Y -19-11DEC85

M50183 -UN-22DEC89



## Fuel Pump and Fuel Tank/Fuel Tank

3. Push rubber bushing into tank.
4. Push fuel sensor into rubber bushing.



M21,3005S,Z -19-11DEC85

M50184 -UN-22DEC89

### INSTALL FUEL TANK

1. Install tank. Put overflow tube through clip on back of frame.
2. Put wiring harness under foam pad and connect harness to fuel sensor.



M21,3005S,AA -19-11DEC85

M50179 -UN-22DEC89

3. Put fuel line under foam pad and connect line to shut-off valve.



M21,3005S,AB -19-11DEC85

M50178 -UN-22DEC89

## Fuel Pump and Fuel Tank/Fuel Tank

4. Put platform on frame. Put seat switch connector through platform. Make sure all levers fit through platform.
5. Install and tighten two nuts, washers and three cap screws.
6. Install pedestal shroud.
7. Connect seat switch.
8. Install control knobs.



M50177 -UN-22DEC89

M21,3005S,AC -19-11DEC85

30  
05  
6

# Section 40 Electrical

## Contents

### Page

#### Group 05—Electric PTO Clutch

Stator, Ignition Coil and Starter	
Repair—Use CTM-5 . . . . .	40-05-1
Other Materials . . . . .	40-05-1
Electric PTO Clutch	
Adjust . . . . .	40-05-1
Remove . . . . .	40-05-2
Ogura Electric PTO Clutch	
Disassemble . . . . .	40-05-2
Inspect . . . . .	40-05-4
Test . . . . .	40-05-5
Assemble . . . . .	40-05-5
Warner Electric PTO Clutch	
Disassemble . . . . .	40-05-7
Inspect . . . . .	40-05-8
Assemble . . . . .	40-05-8
Install Electric PTO Clutch . . . . .	40-05-9

40



**REMOVAL AND INSTALLATION OF STARTER AND IGNITION COIL AND STARTER REPAIR—USE CTM-5**

For complete repair information the component technical manual (CTM) is also required.

Use the component manual in conjunction with this machine manual.



TS225  
-UN-17JAN89

M21,4005S,A1 -19-18APR88

**OTHER MATERIAL**

Number	Name	Use
PT569	NEVER-SEEZ® Lubricant	Lubricate Crankshaft

*NEVER-SEEZ is a trademark of the Never-Seez Corporation.*

M21,4005S,A -19-03FEB86

40  
05  
1

**ADJUST ELECTRIC PTO CLUTCH**

1. Make sure PTO switch is in OFF position. Disconnect spark plug wire and remove key.
2. Insert a 0.41 mm (0.016 in.) feeler gauge through slot in clutch plate. Gauge should be between clutch rotor and armature.
3. Tighten lock nut until feeder gauge begins to bind between armature and rotor. Use a sweeping motion with feeler gauge while making this adjustment. **DO NOT** overtighten.
4. Repeat procedure on other two adjusting nuts.
5. Connect spark plug wire and start engine. Move PTO switch to ON position. If clutch does not engage, test electrical connections for continuity or disassemble PTO for inspection and repair.



M50458  
-UN-03JAN90

M21,4005S,C -19-03FEB86

## REMOVE ELECTRIC PTO CLUTCH

1. Disconnect wiring harness (A).
2. Remove cap screw and washer.
3. If clutch is stuck on crankshaft, use a plastic hammer to loosen clutch from crankshaft. Remove clutch.



M21,4005S,D -19-03FEB86

M50438  
-UN-03JAN90

## DISASSEMBLE OGURA ELECTRIC PTO CLUTCH

*NOTE: This clutch is manufactured by Ogura Clutch Co., Ltd.*

1. Remove three lock nuts.



M21,4005S,E -19-03FEB86

M50439  
-UN-31AUG88

2. Support PTO clutch assembly on armature housing. Press on rotor shaft only and remove armature assembly.

3. Remove three springs (A).



M21,4005S,F -19-03FEB86

M50440  
-UN-31AUG88

4. Remove snap ring.



M21,4005S,G -19-03FEB86

M50441  
-UN-31AUG88

5. Press bearing and spacer form armature housing.



M50442 -UN-31AUG88



M50443 -UN-31AUG88

M21,4005S,H -19-03FEB86

6. Press rotor from electrical coil assembly using 1-5/16 in. disk.



M50444 -UN-31AUG88

M21,4005S,I -19-03FEB86

7. Remove snap ring.



M50445 -UN-31AUG88

M21,4005S,J -19-03FEB86

8. Press bearing from electrical coil assembly.



M50446 -UN-31AUG88

M21,4005S,K -19-03FEB86

### INSPECT ELECTRIC PTO CLUTCH

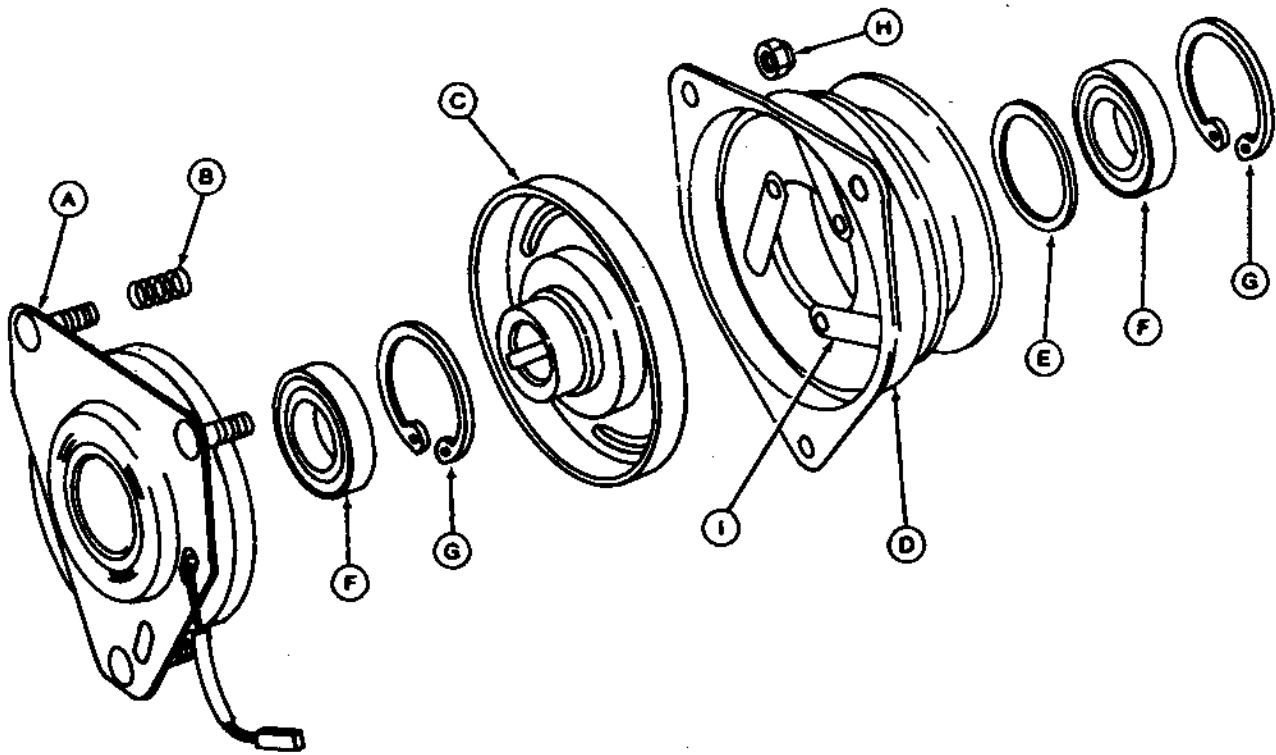

M50456 -UN-31AUG88

A—Electric Coil Assembly  
B—Spring (3 used)  
C—Rotor

D—Armature Housing  
E—Spacer (2 used)

F—Bearing (2 used)  
G—Snap Ring

H—Lock Nut (3 used)  
I—Contact Springs

1. Inspect bearings (F) for wear or damage. Replace if necessary.

2. Inspect springs (B) for broken condition. Replace springs if necessary.

3. Inspect contact surfaces of rotor (C) and armature (D) for scored or grooved condition. Check for weak or broken contact springs (I). Replace parts as needed.

M21,4005S,L -19-27MAR86



## TEST ELECTRICAL COIL

*NOTE: Battery must be fully charged and in good condition for a proper test.*

1. Connect 12-volt battery to PTO electrical leads.
2. Put a tool across coil. Electromagnetic action will hold tool to coil if PTO coil is in good condition. If tool is not attracted to coil, replace coil.

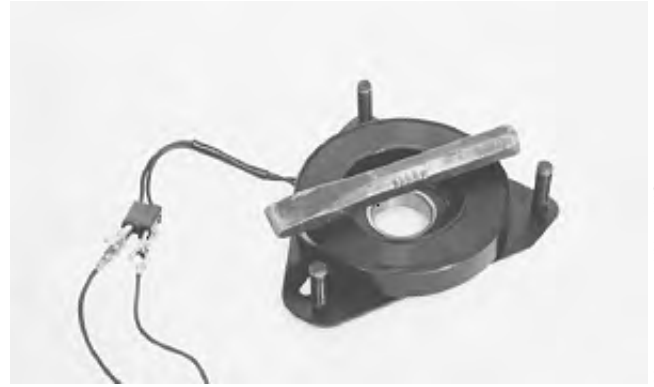

M21,4005S,M -19-03FEB86

M50451  
-UN-31AUG88

## ASSEMBLE ELECTRIC PTO CLUTCH

1. Press bearing into electrical coil assembly.



M21,4005S,N -19-03FEB86

M50447  
-UN-31AUG88

2. Install snap ring.



M21,4005S,O -19-03FEB86

M50445  
-UN-31AUG88

3. Press rotor into electrical coil assembly.



M21,4005S,P -19-03FEB86

M50448  
-UN-31AUG88

Electric PTO Clutch/Ogura Electric PTO Clutch

4. Put spacer in armature housing. Press bearing against spacer.



M50443 -UN-31AUG88



M50449 -UN-31AUG88

M21,4005S,Q -19-03FEB86

5. Install snap ring.



M50441 -UN-31AUG88

M21,4005S,R -19-03FEB86

6. Install springs (A) and press armature housing onto rotor.

7. Install lock nuts.

8. Adjust PTO clutch after installing on tractor. (See Adjust Electric PTO Clutch in Section 240.)



M50450 -UN-31AUG88

M21,4005S,S -19-19DEC86

## DISASSEMBLE WARNER ELECTRICAL PTO CLUTCH

*NOTE: This clutch is manufactured by Warner Electric Brake and Clutch Co.*

1. Remove spacer.



M21,4005S,T -19-03FEB86

M50452  
-UN-03JAN90

2. Remove three nuts.



M21,4005S,U -19-03FEB86

M50453  
-UN-03JAN90

3. Remove armature assembly and three springs (A).



M21,4005S,V -19-03FEB86

M50454  
-UN-03JAN90

4. Remove rotor.



M21,4005S,W -19-03FEB86

M50455  
-UN-03JAN90

## INSPECT ELECTRICAL PTO CLUTCH

1. Inspect bearings (A) for wear or damage. Replace bearings or housing assemblies as needed.
2. Inspect springs (C) for broken condition. Replace springs if necessary.
3. Inspect contact surfaces of rotor (D) and armature (E) for scored or grooved condition. Check for weak or broken contact springs (F). Replace parts as needed.

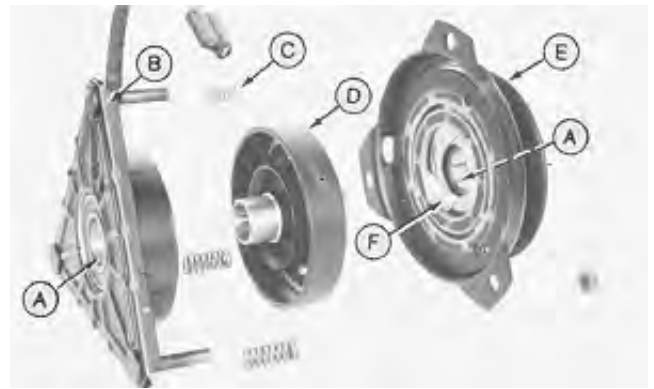

- A—Bearing (2 used)
- B—Electric Coil Housing Assembly
- C—Spring (3 used)
- D—Rotor
- E—Armature Housing Assembly
- F—Contact Spring

M21,4005S,X -19-03FEB86

M50457 -UN-03JAN90

40  
05  
8

## ASSEMBLE ELECTRIC PTO CLUTCH

1. Install rotor on electrical coil assembly.



M21,4005S,Y -19-03FEB86

M50455 -UN-03JAN90

2. Install three springs (A).
3. Install armature housing assembly.
4. Install three nuts.
5. Install spacer.
6. Adjust PTO clutch before installing on tractor. (See Adjust Electric PTO Clutch in this group.)



M21,4005S,Z -19-03FEB86

M50454 -UN-03JAN90

## INSTALL ELECTRIC PTO CLUTCH

1. Put NEVER-SEEZ lubricant on crankshaft.
2. Install PTO clutch on crankshaft with pin on tractor through slot in electric coil housing.
3. Install cap screw and washer. Hold flywheel and tighten cap screw to 56 N·m (45 lb-ft).
4. Connect wiring harness (A).



M21,4005S,A2 -19-13MAY88

M50459 -UN-03JAN90

40  
05  
9

40  
05  
10

# Section 50

## Power Train

### Contents

	Page	Page
<b>Group 05—Powered Wheels</b>		
Other Materials . . . . .	50-05-1	
Replace Rear Wheels		
130, 160 and 180 . . . . .	50-05-1	
165, 175 and 185 . . . . .	50-05-1	
<b>Group 10—Traction Drive Clutch</b>		
Other Materials . . . . .	50-10-1	
Traction Drive Belt		
Care and Maintenance . . . . .	50-10-1	
Inspect . . . . .	50-10-2	
Clean . . . . .	50-10-2	
Replace Drive Belt		
130, 160, 180 and 185 (S.N.		
475001— ) . . . . .	50-10-2	
165, 175 and 185 (S.N. 475000—) . . . . .	50-10-4	
Adjust Drive Belt—130, 160 and 180 . . . . .	50-10-5	
Clutch—130, 160, 180 and 185 (S.N.		
475001—) . . . . .	50-10-6	
Install . . . . .	50-10-7	
Tensioner—165, 175 and 185		
(S.N.—475000)		
Remove . . . . .	50-10-8	
Install . . . . .	50-10-8	
<b>Group 15—5-Speed Transaxle</b>		
Other Material . . . . .	50-15-1	
Transaxle		
Remove . . . . .	50-15-1	
Disassemble . . . . .	50-15-4	
Assemble . . . . .	50-15-9	
Install . . . . .	50-15-13	
Adjust Transmission Control Lever—130,		
160 and 180 . . . . .	50-15-17	
<b>Group 20—Hydrostatic Transmission—Eaton</b>		
Essential Tools . . . . .	50-20-1	
Service Equipment and Tools . . . . .	50-20-1	
Other Materials . . . . .	50-20-1	
Service Parts Kits . . . . .	50-20-2	
Remove Differential and Hydrostatic		
Transmission . . . . .	50-20-2	
Transmission		
Remove . . . . .	50-20-4	
Disassemble . . . . .	50-20-5	
Inspect . . . . .	50-20-8	
Assemble . . . . .	50-20-14	
Fill Reservoir . . . . .	50-20-18	
Install . . . . .	50-20-19	
Install Differential and Hydrostatic		
Transmission . . . . .	50-20-19	
<b>Group 21—Hydrostatic Transmission—Sundstrand</b>		
Other Materials . . . . .	50-21-1	
Separate Differential and Transmission . . . . .	50-21-1	
Transmission		
Disassemble . . . . .	50-21-2	
Assemble . . . . .	50-21-3	
Assemble Differential and Transmission . . . . .	50-21-5	
Bleed Hydrostatic System . . . . .	50-21-5	
<b>Group 25—Hydrostatic Differential—Peerless</b>		
Other Materials . . . . .	50-25-1	
Hydrostatic Differential		
Remove . . . . .	50-25-1	
Disassemble . . . . .	50-25-1	
Inspect . . . . .	50-25-5	
Assemble . . . . .	50-25-5	
Install . . . . .	50-25-8	
<b>Group 26—hydrostatic Differential—Kanzaki</b>		
Other Materials . . . . .	50-26-1	
Separate Differential and Transmission . . . . .	50-26-1	
Differential		
Disassemble . . . . .	50-26-2	
Assemble . . . . .	50-26-4	
Assemble Differential and Transmission . . . . .	50-26-7	





**OTHER MATERIAL**

Number	Name	Use
PT569	NEVER-SEEZ® Lubricant	Lubricate Rear Axle

*NEVER-SEEZ is a trademark of the Never-Seez Corporation.*

M21,5005S,ZA -19-23JAN86

**REPLACE REAR WHEELS—130, 160 AND 180**

1. lift rear of tractor so rear wheels are off the ground. Put blocks or supports under tractor frame.
2. Remove snap ring and washer. Remove wheel.



M50255 -UN-22DEC89

M21,5005S,A1 -19-18APR88

3. Inspect shaft key and washer. Replace if necessary.
4. Put NEVER-SEEZE lubricant on axle.
5. Install washers and snap ring.
6. Measure clearance between wheel hub and axle housing. Add washers behind snap ring until clearance is 0.25—1.02 mm (0.010—0.040 in.).
7. Remove blocking from tractor.



M50256 -UN-22DEC89

M21,5005S,A2 -19-18APR88

**REPLACE REAR WHEELS—165, 175 AND 185**

1. Lift rear of tractor so rear wheels are off the ground. Put blocks or supports under tractor frame.
2. Remove snap ring.



M50253 -UN-22DEC89

M21,5005S,A3 -19-18APR88

## Powered Wheels/Replace Rear Wheels

3. Pull wheel off axle.
4. Inspect washer (B) and shaft key (A) on right axle. Inspect three washers (C) on left axle only.
5. Put NEVER-SEEZE lubricant on shaft and install wheel.
6. Install snap ring.
7. Measure clearance between wheel hub and axle housing. Add washers (C) between hub and axle housing until clearance is 0.25—1.02 mm (0.010—0.040 in.).
8. Remove blocking from tractor.

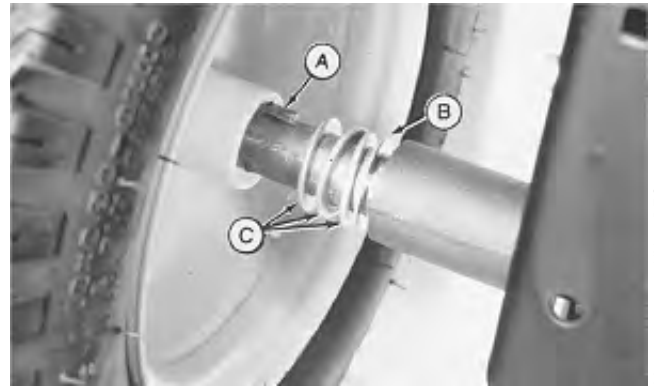

Left Side shown

M50254 -UN-22DEC89

M21,5005S,A4 -19-18APR88

50-05-2

## OTHER MATERIAL

Number	Name	Use
PT569	NEVER-SEEZ® Lubricant	Lubricate Bell Crank, Bushings and Sleeve Ends

NEVER-SEEZ is a trademark of the Never-Seez Corporation.

M21,5010S,ZA -19-23JAN86

## TRACTION DRIVE BELT CARE AND MAINTENANCE

1. The traction drive belt transmits power by friction and a wedging action against the sheaves. The belt is subject to normal wear through periodic heavy load and should be checked regularly. To check for normal wear, the belt and sides of sheaves should wear evenly.

2. A slight raveling of the belt covering does not indicate premature failure. Cut off the raveling if the covering peels at the lap.

3. Check for the causes of unusual belt wear as follows:

—Examine sheaves for bent or chipped sidewalls (A). Check for excessive sidewall wear (B). Damaged sheaves cause rapid belt wear. A bent sidewall (C) reduces the gripping power of the belt. Replace sheaves having any of the above defects.

—Check to be sure dirt has not lodged and packed in sheave V-groove. Loosen dirt so it will fall out when tractor is started.

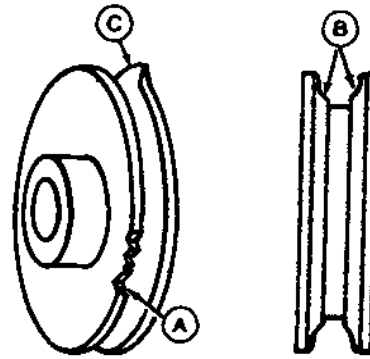

M50314 -UN-26APR89

50  
10

M21,5010S,A -19-27MAR86

## INSPECT TRACTION DRIVE BELT

**IMPORTANT:** Never pry belt over edge of sheave.  
Belt cords may be damaged. Put belt in sheave groove by hand.

1. Lumpy traction drive belts can cause tractor vibration. Check belt for swells and lumps. Install only factory recommended drive belts of the proper length.
2. Whenever unusual traction drive belt failure occurs, check immediately for the cause. After correcting the cause, replace drive belt.

M21,5010S,B -19-27MAR86

## CLEAN TRACTION DRIVE BELT

**CAUTION:** Do not clean belt while tractor is running.

1. Clean belt by wiping with a clean cloth. Immediately wipe off any spilled oil or grease. Do not use solvents. They soften the belt and cause the clutch to grab.
2. Do not use belt dressing. Dressings shorten belt life and often give only temporary gripping action while softening the belt and causing eventual deterioration.

M21,5010S,C -19-23JAN86

## REPLACE TRACTION DRIVE BELT—130, 160, 180 AND 185 (S.N. 475001— )

1. Remove mower from tractor.
2. Remove electric PTO clutch. (See Section 40, Group 05.)
3. Loosen adjusting idler nut.

*NOTE:* Idler is not on 185 (S.N. 475001— ).



M50317 -UN-22DEC89

M21,5010S,A1 -19-13MAY88

## Traction Drive Clutch/Replace Drive Belt

4. Remove two cap screws and nuts. Rotate steering support so it is parallel to drive belt.

5. Disconnect drag link (A).

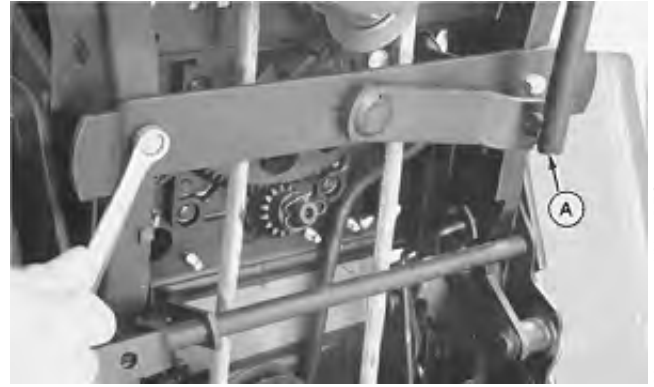

M21,5010S,E -19-23JAN86

M50318 -UN-22DEC89

6. Loosen two nuts and remove belt guide (A).



M21,5010S,F -19-23JAN86

M50320 -UN-22DEC89

7. Remove two cap screws and nuts (A) and rotate clutch support parallel to drive belt.

8. Depress clutch pedal and remove drive belt from sheaves.

9. Replace drive belt on sheaves.

10. Install and tighten two cap screws and nuts (A) on clutch support.

11. Install belt guide on clutch assembly.



M21,5010S,G -19-23JAN86

M50321 -UN-22DEC89

## Traction Drive Clutch/Replace Drive Belt

12. Connect drag link (A). Install and tighten two cap screws and nuts on steering support.

13. Adjust traction drive belt. (See Adjust Traction Drive Belt for Models 130, 160, and 180 in this group.)

14. Install mower on tractor.

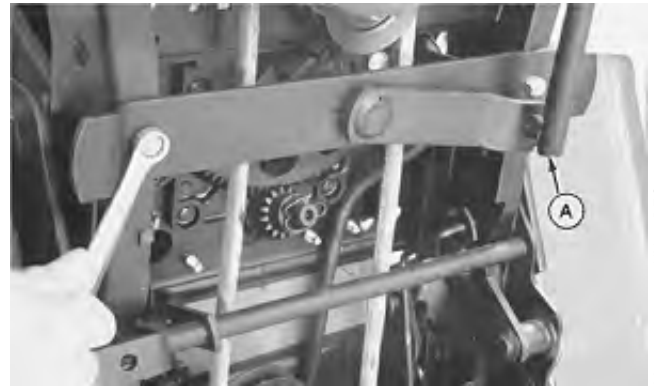

M21,5010S,H -19-23JAN86

M50318  
-UN-22DEC89

### REPLACE TRACTION DRIVE BELT—165, 175 AND 185 (S.N. —475000)

1. Remove mower from tractor.

2. Remove electric PTO clutch. (See Section 40, Group 05.)

3. Remove two cap screws and nuts. Rotate steering support so it is parallel to drive belt.

4. Disconnect drag link (A).



185 (S.N. —475000) Shown

M21,5010S,A2 -19-13MAY88

M50327  
-UN-22DEC89

5. Remove pin (A) and disconnect transmission linkage.

6. Remove traction drive belt.



M21,5010S,J -19-23JAN86

M50328  
-UN-22DEC89

7. Install drive belt (A) on transmission sheave, idler assembly, engine sheave and idler. Be sure drive belt is routed from right-hand side of engine sheave to TOP of the transmission sheave.
8. Connect linkage to transmission.
9. Fasten steering support with two cap screws and nuts. Connect drag link to steering arm.
10. Install electric PTO clutch. (See Section 40, Group 05.)

*NOTE: There is no adjustment on the traction drive belt for hydrostatic tractors.*

11. Install mower on tractor.

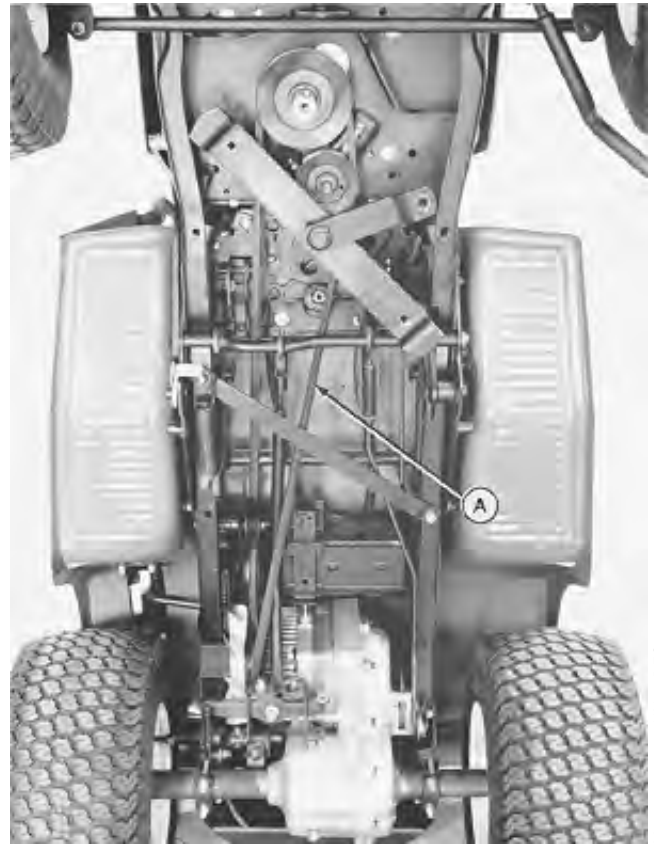

M21,5010S,A3 -19-18APR88

M50329 -UN-22DEC89

50-10-5

### ADJUST TRACTION DRIVE BELT—MODELS 130, 160, AND 180

1. Remove mower from tractor.
2. Put transmission control lever in gear to hold tractor. DO NOT engage parking brake.
3. Put foot clutch in engaged or in up position.
4. Loosen nut on adjusting idler.
5. Slide adjusting idler in slot until a dimension (A) of 94 mm (3.7 in.) is obtained between inner surface of flat idler and inside of frame.
6. Adjust belt guide (B) to be parallel with drive belt and maintain a clearance of 5 mm (0.20 in.) between belt and guide.
7. Tighten nut on adjusting idler.

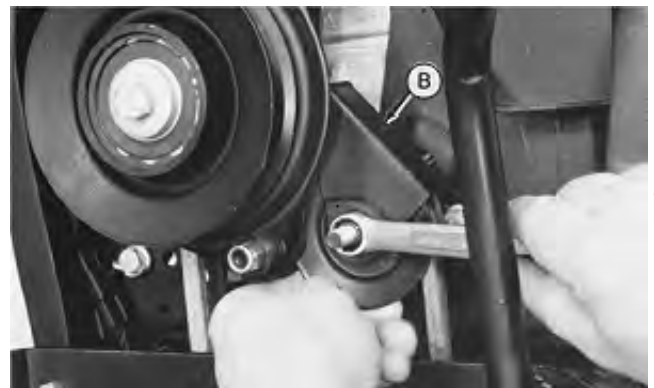

M50323 -UN-22DEC89

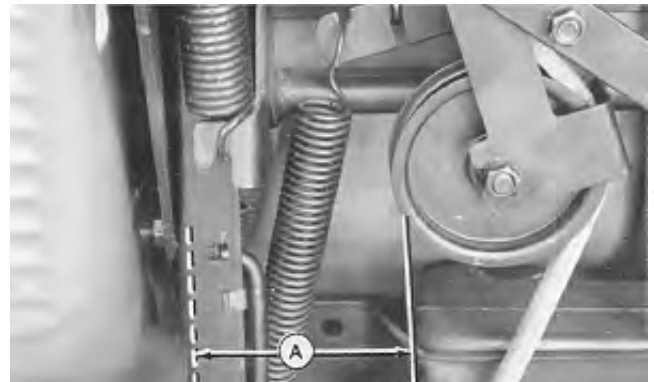

M50322 -UN-22DEC89

M21,5010S,L -19-23JAN86

8. Loosen belt guide (A) and center belt in guide loop. Tighten cap screw.
9. Install mower on tractor.



M21,5010S,M -19-23JAN86

M50324 -UN-22DEC89

### REMOVE TRACTION DRIVE CLUTCH ASSEMBLY—130, 160, 180 AND 185 (S.N. 475001— )

1. Loosen two nuts and remove belt guide (A).



M21,5010S,A4 -19-13MAY88

M50320 -UN-22DEC89

2. Remove clutch spring (A) and return spring (B).

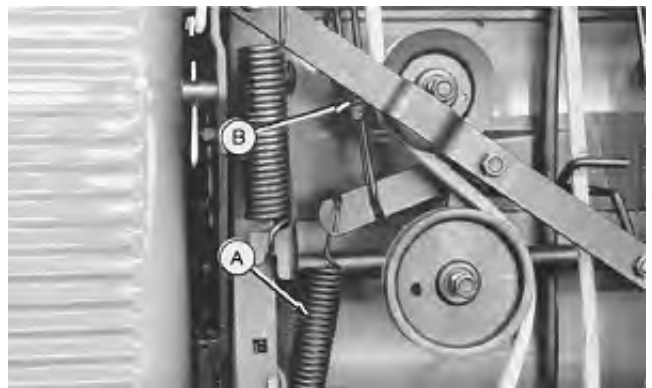

M21,5010S,O -19-23JAN86

M50319 -UN-22DEC89



## Traction Drive Clutch/Install

3. Remove clutch support (A) and clutch assembly.

4. Inspect clutch assembly for wear or damage. Replace parts as needed.

- A—Clutch Support
- B—Washer
- C—Bushing (2 used)
- D—Sleeve
- E—Bell Crank
- F—V-Groove Idler
- G—Flat Idler

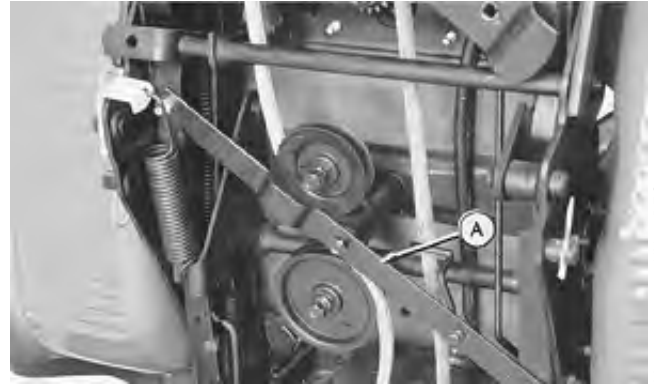

M21,5010S,P -19-27MAR86

M50325 -UN-22DEC89

M50326 -UN-22DEC89

50  
10  
7

### INSTALL TRACTION DRIVE CLUTCH ASSEMBLY—130, 160, 180 AND 185 (S.N. 475001— )

1. Put NEVER-SEEZE lubricant on bushings (C) and ends of sleeve (D). Put bushings and sleeve in bell crank (E).
2. Install traction clutch assembly and clutch support (A). Tighten three nuts.
3. Install return spring and clutch spring.
4. Install belt guide.
5. Adjust traction drive belt. (See this group.)

- A—Clutch Support
- B—Washer
- C—Bushing (2 used)
- D—Sleeve
- E—Bell Crank
- F—V-Groove Idler
- G—Flat Idler

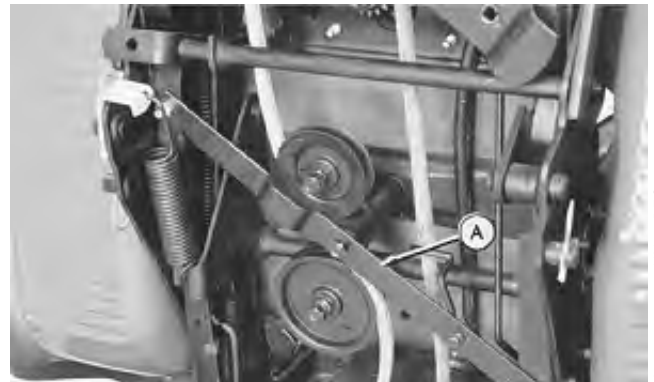

M21,5010S,A5 -19-13MAY88

M50326 -UN-22DEC89

M50325 -UN-22DEC89

### REMOVE BELT TENSIONER—165, 175 AND 185 (S.N. —475000)

1. Remove traction drive belt. (See this group.)
2. Disconnect spring (A) from frame.
3. Remove nut and belt tensioner assembly.
4. Inspect tensioner for wear or damage. Replace parts as necessary.



M21,5010S,A6 -19-13MAY88

M50330 -UN-22DEC89

### INSTALL BELT TENSIONER—165, 175 AND 185 (S.N. —475000)

1. Put NEVER-SEEZE lubricant on bushings (A) and ends of sleeve (C).

- A—Bushings (2 used)
- B—Bell Crank
- C—Sleeve
- D—Washer
- E—Flat Idler
- F—V-Groove Idler

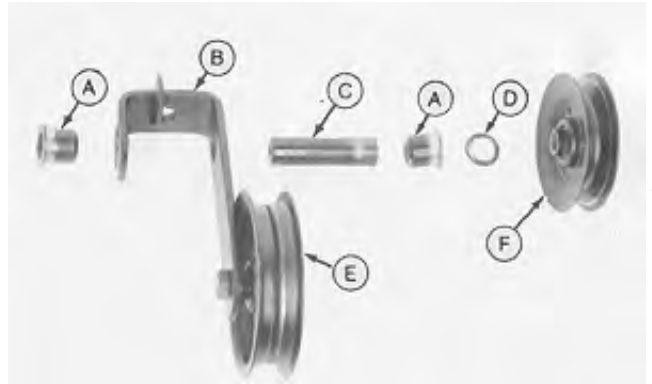

M21,5010S,A7 -19-13MAY88

M50331 -UN-22DEC89

2. Install belt tensioner parts on cap screw one part at a time. Connect spring (A) to bell crank.
3. Install and tighten nut.
4. Connect spring (A) to shaft on pedal assembly.
5. Install traction drive belt. (See Replace Traction Drive Belt for Models 165, 175 and 185 in this group.)



M21,5010S,A8 -19-16MAY88

M50330 -UN-22DEC89

## OTHER MATERIAL

Number	Name	Use
	John Deere HIGH TEMPERATURE Grease	Lubricate Brake Shaft Keyways, Needle Bearings, and Transaxle Gears

M21,5015S,ZA -19-23JAN86

## REMOVE TRANSAXLE

1. Remove mower.
2. Put transmission control lever in neutral.
3. Remove rear wheels. (See Replace Rear Wheels in Section 50, Group 05.)
4. Depress clutch pedal and remove traction drive belt from transaxle drive sheave.
5. Disconnect brake linkage.
6. Disconnect neutral start switch wire (A).

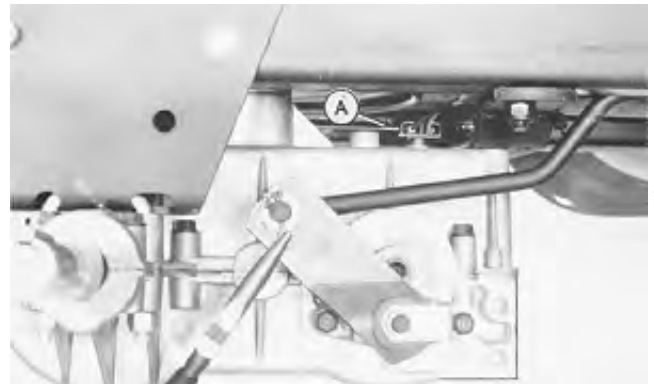

M50257 -UN-22DEC89

50  
15

M21,5015S,A -19-31DEC85

7. Remove two cap screws and nuts from front support.



M50258 -UN-22DEC89

M21,5015S,B -19-31DEC85

## 5-Speed Transaxle/Transaxle

8. Remove cap screw and washer. Disconnect shift arm.



M21,5015S,C -19-31DEC85

M50259  
-UN-22DEC89

9. Remove four nuts from U-bolt and lower transaxle from tractor.

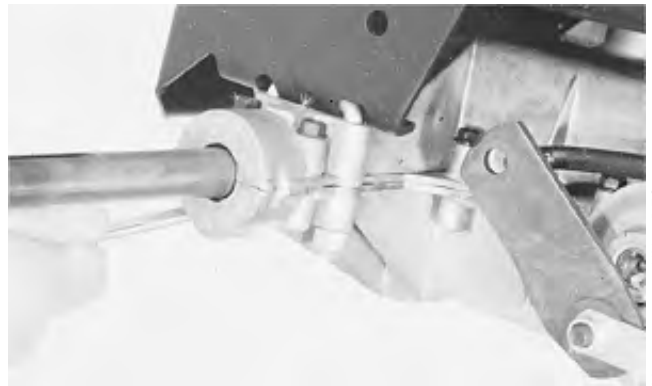

M21,5015S,D -19-31DEC85

M50260  
-UN-22DEC89

### REMOVE EXTERNAL TRANSAXLE PARTS

1. Remove two self-tapping screws and remove support.
2. Remove snap ring (A). Remove transaxle drive sheave and key.

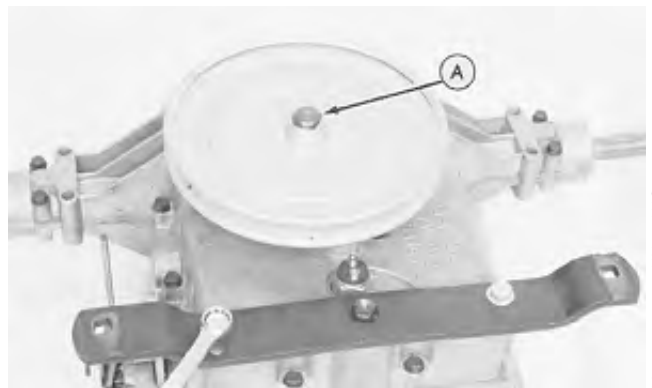

M21,5015S,E -19-31DEC85

M50261  
-UN-31AUG88

3. Remove neutral start switch.



M21,5015S,F -19-31DEC85

M50262  
-UN-22DEC89

## 5-Speed Transaxle/Transaxle

4. Remove two cap screws and washers. Remove brake assembly, disk and brake puck.



M21,5015S,G -19-31DEC85

M50397  
-UN-03JAN90

### REMOVE INTERNAL COMPONENTS

1. Remove Allen-head screw. Remove spring and detent ball with a magnet.



M21,5015S,Q -19-23JAN86

M50398  
-UN-31AUG88

2. Remove 17 cap screws. Tap sides of case with a plastic hammer and remove top half of case.



M21,5015S,R -19-23JAN86

M50399  
-UN-31AUG88

3. Remove shifter fan.



M21,5015S,S -19-23JAN86

M50400  
-UN-31AUG88

## 5-Speed Transaxle/Transaxle

4. Lift gear assembly out of case as one unit.



M21,5015S,T -19-23JAN86

M50401  
-UN-31AUG88

5. Lift differential assembly out.

6. Remove old grease from case halves and parts. Wash parts with solvent.



M21,5015S,U -19-23JAN86

M50402  
-UN-31AUG88

### DISASSEMBLE INPUT SHAFT

1. Remove snap ring and pinion gear (A).

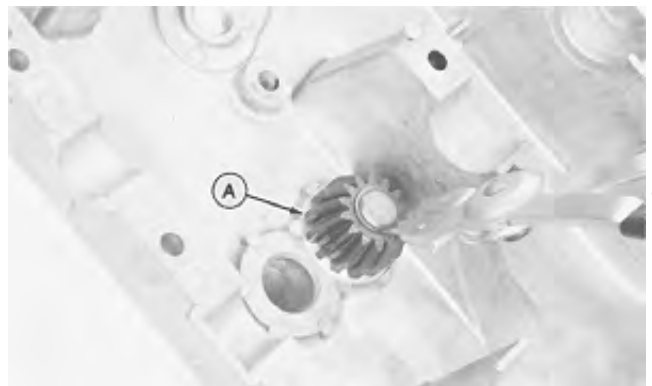

M21,5015S,V -19-23JAN86

M50403  
-UN-31AUG88

2. Remove thrust washer and O-ring.



M21,5015S,W -19-23JAN86

M50404  
-UN-31AUG88

50  
15  
4

## 5-Speed Transaxle/Transaxle

3. Remove input shaft, thrust washer (A), and snap ring (B).

4. Inspect input shaft, pinion gear, O-ring, and thrust washers for wear or damage. Replace parts if necessary.



M21,5015S,X -19-23JAN86

M50405  
-UN-31AUG88

5. Inspect input shaft bearings (A) for wear. Replace if necessary.

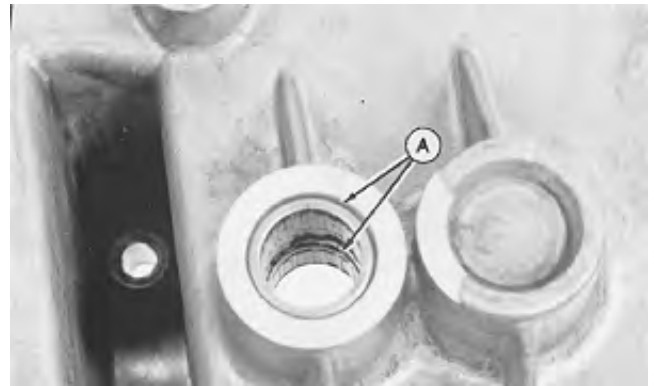

M21,5015S,Y -19-23JAN86

M50406  
-UN-03JAN90

### DISASSEMBLE GEAR ASSEMBLY

1. Remove needle bearing (A), square cut seal (B), thrust washer (C), output gear (D), and output pinion (E).

- A—Needle Bearing
- B—Square Cut Seal
- C—Thrust Washer
- D—Output Gear
- E—Output Pinion

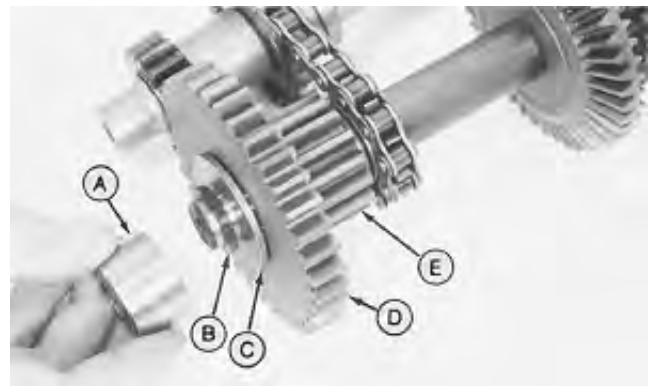

M21,5015S,Z -19-23JAN86

M50407  
-UN-03JAN90

2. Inspect needle bearing (A) for wear. Replace if necessary.



M21,5015S,AA -19-23JAN86

M50408  
-UN-03JAN90

## 5-Speed Transaxle/Transaxle

3. Remove O-rings from each end of output pinion. Inspect needle bearings (A) for wear. Replace if necessary.



M21,5015S,AB -19-23JAN86

M50409  
-UN-31AUG88

4. Pull ends of shafts together and remove drive chain.



M21,5015S,AC -19-23JAN86

M50410  
-UN-31AUG88

5. Remove sprocket (A), bushing (B), thrust washer (C), spur gears (D), and bevel gear (E) from countershaft.

- A—Sprocket
- B—Bushing
- C—Thrust Washer
- D—Spur Gears (5 used)
- E—Bevel Gear

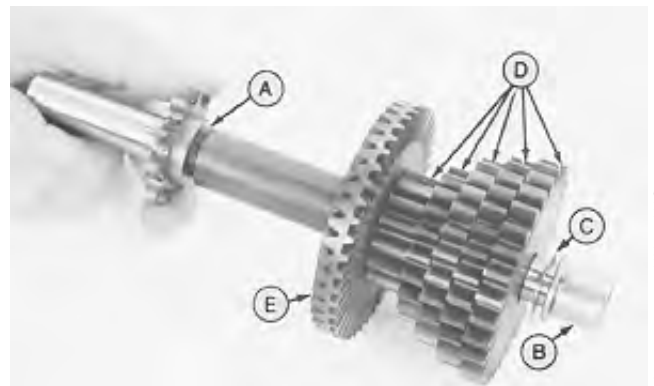

M21,5015S,AD -19-23JAN86

M50411  
-UN-31AUG88

6. Remove square cut seal (A), bushing (B), and thrust washer (C) from shifter and brake shaft.

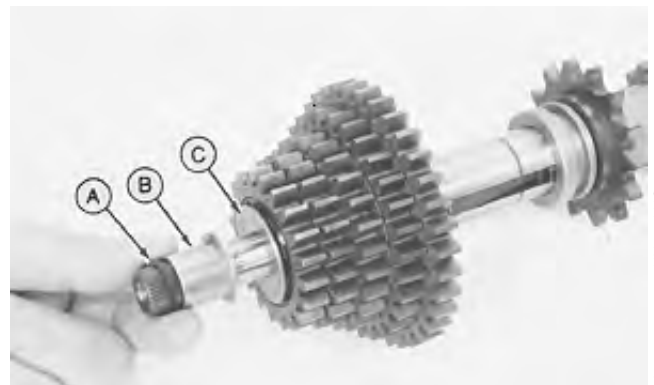

M21,5015S,AE -19-23JAN86

M50412  
-UN-31AUG88



## 5-Speed Transaxle/Transaxle

**NOTE:** Observe the position of thrust washers (B) on shifter and brake shaft. Raised back side of washer is away from brake spline.

7. Remove spur gears (A) and thrust washers (B) alternately.

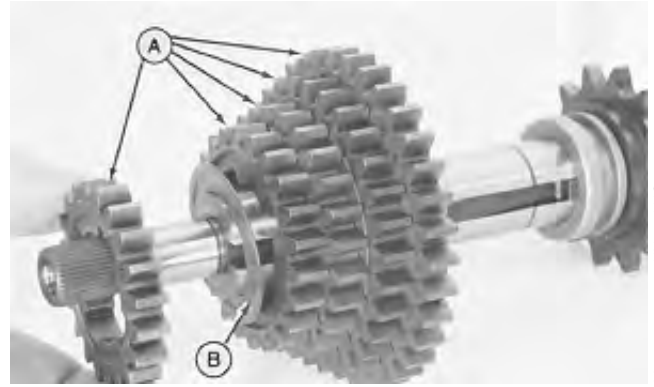

M21,5015S,AF -19-23JAN86

M50413  
-UN-31AUG88

8. Remove bushing (A), thrust washer (B), spur gear (C), spacer (D), and sprocket (E).

- A—Bushing
- B—Thrust Washer
- C—Spur Gear
- D—Spacer
- E—Sprocket

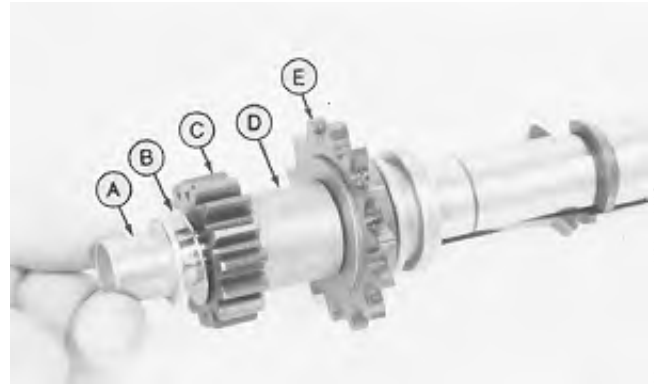

M21,5015S,AG -19-23JAN86

M50414  
-UN-31AUG88

9. Remove shifter collar (A) and keys (B).

10. Inspect gears, bushings, washers, and shafts for wear or damage. Replace parts if necessary.

11. Inspect roller chain for damaged or broken links. Replace if necessary.

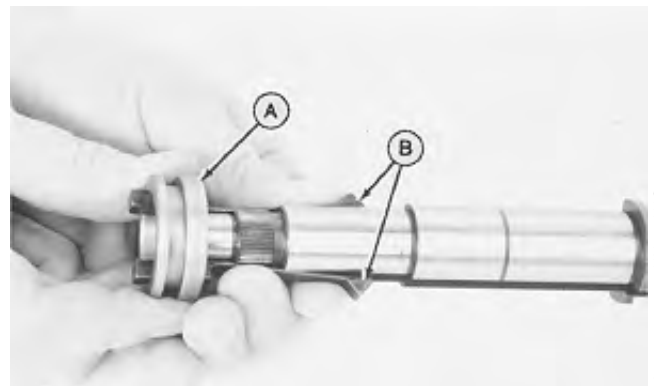

M21,5015S,AH -19-23JAN86

M50415  
-UN-31AUG88

## DISASSEMBLE DIFFERENTIAL

1. Remove ball bearings (A) and bushings (B).

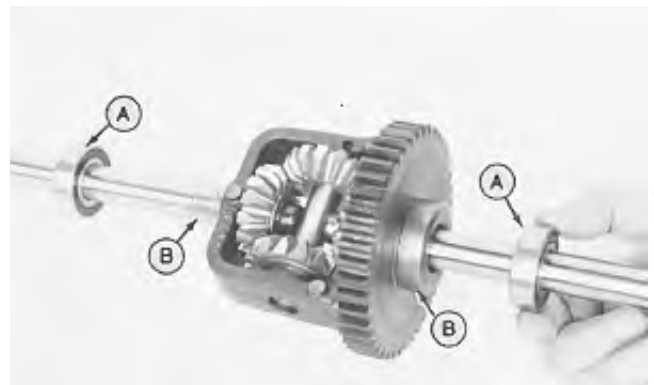

M21,5015S,AI -19-23JAN86

M50416  
-UN-31AUG88

## 5-Speed Transaxle/Transaxle

2. Remove spring pin (A) using a punch.
3. Remove pinion shaft (C) and thrust washers (B).

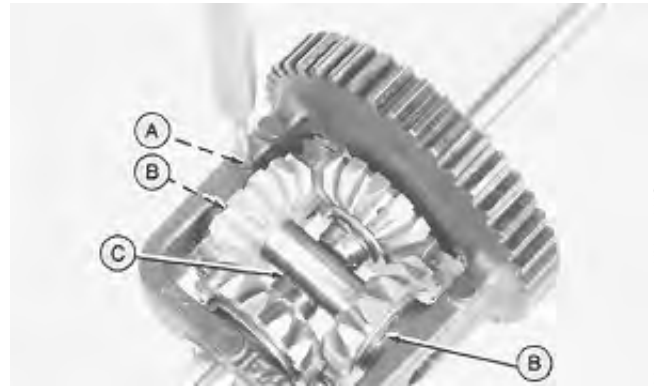

M21,5015S,AJ -19-23JAN86

M50417  
-UN-31AUG88

4. Rotate axle to move pinion gears out of position.  
Remove pinion gears.



M21,5015S,AK -19-23JAN86

M50418  
-UN-31AUG88

5. Remove snap ring. Remove bevel gear (A), thrust washers (B), and axle (C).

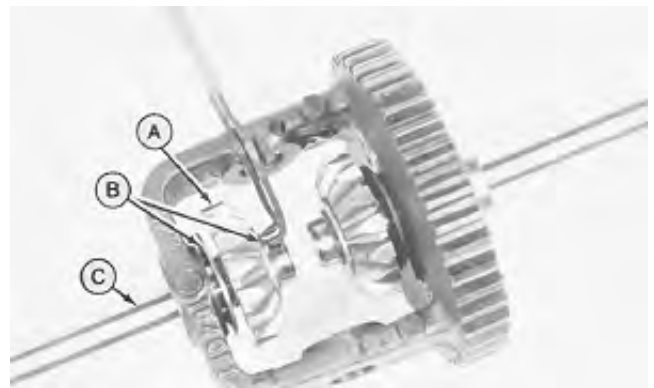

M21,5015S,AL -19-23JAN86

M50419  
-UN-03JAN90

6. Inspect bushings (A) for wear. Replace if necessary.
7. Inspect differential ball bearings, bushings, shafts, and gears for wear or damage. Replace parts if necessary.



M21,5015S,AM -19-23JAN86

M50421  
-UN-03JAN90

## ASSEMBLE DIFFERENTIAL

1. Install shorter axle (A) through gear side of ring gear housing.
2. Install thrust washers (B), bevel gear (C), and snap ring.
3. Install longer axle, thrust washers, bevel gear, and snap ring in ring gear housing.

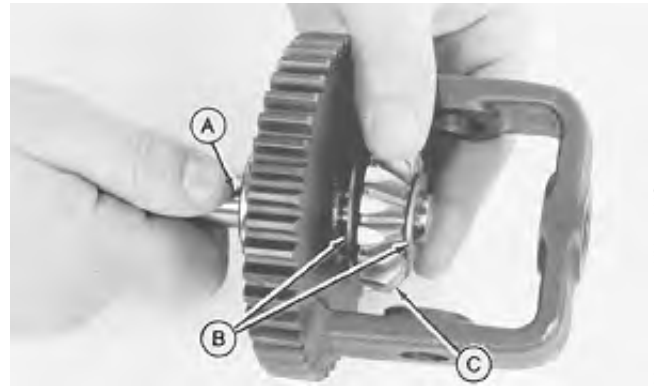

M21,5015S,AN -19-23JAN86

M50420 -UN-31AUG88

4. Install pinion gears on opposite sides of ring gear housing. Rotate axle to move pinion gears into alignment with pinion shaft holes.



M21,5015S,AO -19-23JAN86

M50418 -UN-31AUG88

5. Insert thrust washers (B) behind each pinion gear. Slide pinion shaft (C) through ring gear housing, thrust washers, and pinion gears.

6. Install spring pin (A).

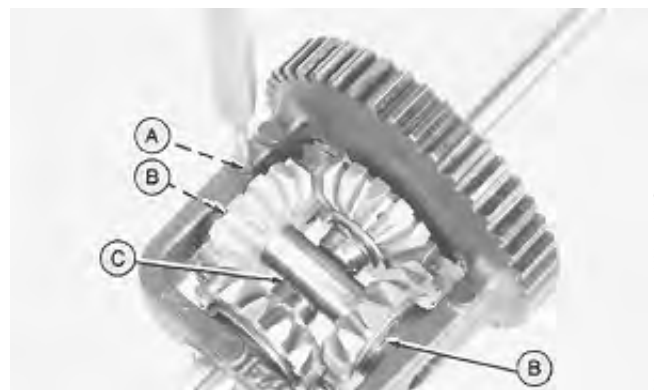

M21,5015S,AP -19-23JAN86

M50417 -UN-31AUG88

7. Install bushings (B) and ball bearings (A).

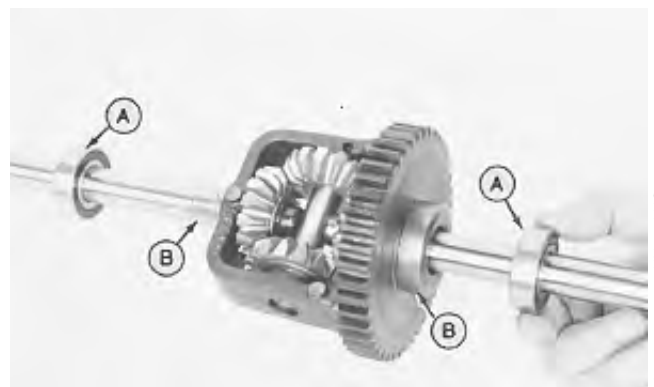

M21,5015S,AQ -19-23JAN86

M50416 -UN-31AUG88

## ASSEMBLE SHIFTER AND BRAKE SHAFT

1. Put John Deere High Temperature Grease or an equivalent in keyways of shaft.
2. Position keys (B) near end of shaft in keyways. Put shifter collar (A) over keys with thicker shoulder of collar towards shaft. Slide collar and keys on shaft.

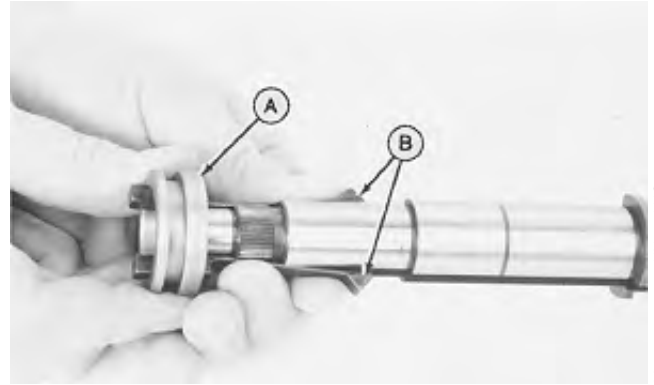

M21,5015S,AR -19-23JAN86

M50415  
-UN-31/AUG88

3. Install sprocket (E) with thicker shoulder towards shifter collar.
4. Install spacer (D), spur gear (C), thrust washer (B), and bushing (A).

- A—Bushing
- B—Thrust Washer
- C—Spur Gear
- D—Spacer
- E—Sprocket

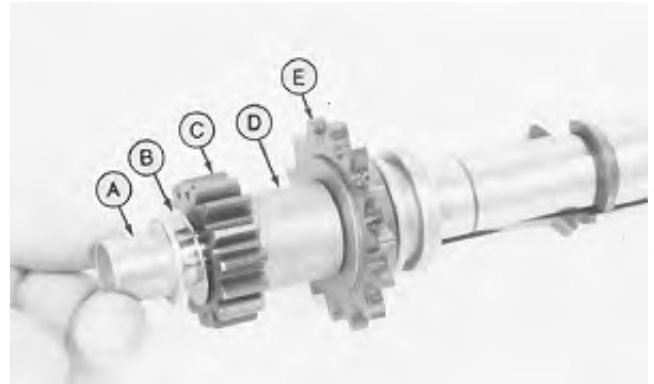

M21,5015S,AS -19-23JAN86

M50414  
-UN-31/AUG88

5. Put five thrust washers (B) and spur gears (A) on shaft with raised side of thrust washers towards shoulder (C) of shaft. Flat side of gears (A) MUST be towards shoulder.

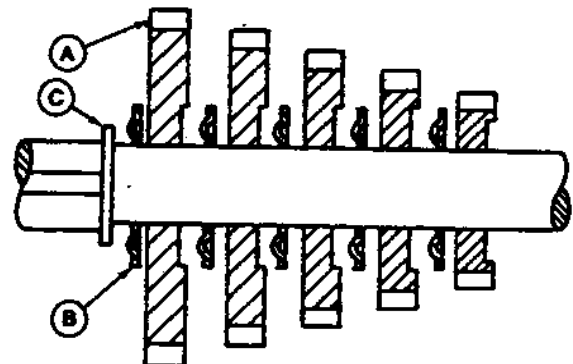
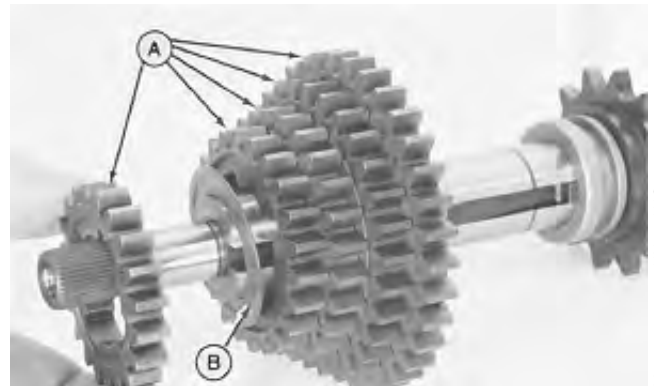

M21,5015S,AT -19-23JAN86

M50413  
-UN-31/AUG88

M50437  
-UN-26/APR89

50  
15  
10

6. Install thrust washer (C), bushing (B), and square cut seal (A).

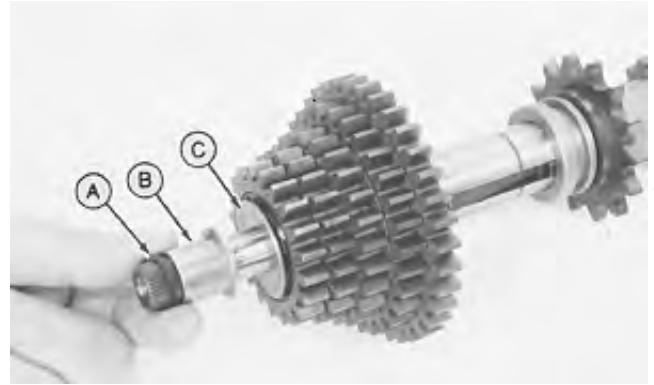

M21,5015S,AU -19-23JAN86

M50412 -UN-31AUG88

### ASSEMBLE COUNTERSHAFT

1. Install bevel gear (E) with bevel towards center of shaft. Install spur gears (D), smallest to largest, thrust washer (C), and bushing (B).
2. Install sprocket (A) with thicker shoulder towards bevel gear (E).

- A—Sprocket
- B—Bushing
- C—Thrust Washer
- D—Spur Gears (5 used)
- E—Bevel Gear

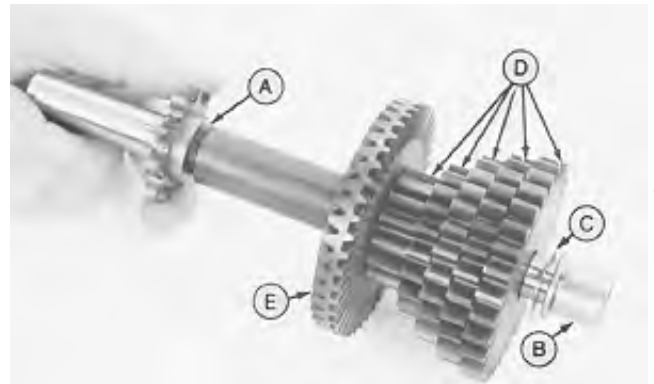

M21,5015S,AV -19-23JAN86

M50411 -UN-31AUG88

3. Put countershaft and shifter and brake shaft ends together. Install drive chain.



M21,5015S,AW -19-23JAN86

M50410 -UN-31AUG88

## 5-Speed Transaxle/Transaxle

4. If needle bearings (A) were removed from output pinion, replace with new bearings. Press bearings to a depth of 3.43—3.81 mm (0.135—0.150 in.) below top surface on each end.

Put John Deere HIGH TEMPERATURE Grease between needle bearings. Put O-rings in each end of output pinion.



M21,5015S,AX -19-23JAN86

M50409 -UN-31AUG88

5. Install output pinion (E), output gear (D), thrust washer (C), square cut seal (B), and needle bearing (A).

- A—Needle Bearings
- B—Square Cut Seal
- C—Thrust Washer
- D—Output Gear
- E—Output Pinion

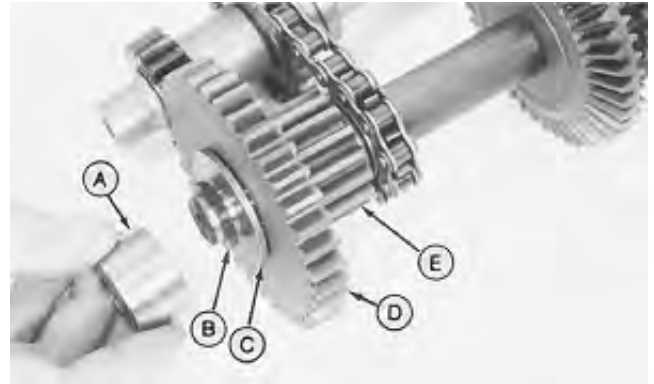

M21,5015S,AY -19-23JAN86

M50407 -UN-03JAN90

### ASSEMBLE INPUT SHAFT

1. If needle bearings (A) were removed from top cover, replace with new bearings. Press top bearing flush with cover. Press lower bearing from inside of cover, to a depth of 3.43—3.81 mm (0.135—0.150 in.) below the surface.

Put JOHN Deere High Temperature Grease between needle bearings.

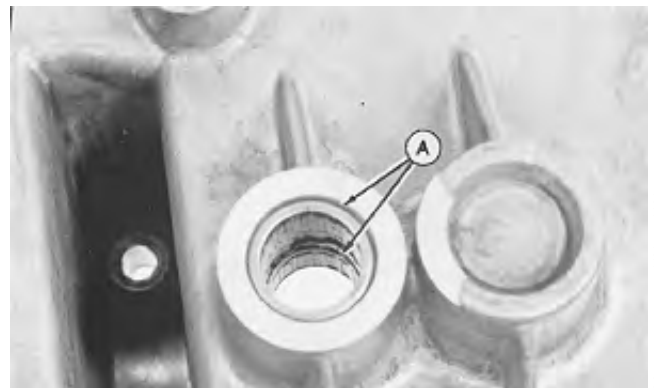

M21,5015S,AZ -19-23JAN86

M50406 -UN-03JAN90

2. Put snap ring (B) and thrust washer (A) on input shaft. Install input shaft in cover.



M21,5015S,BA -19-23JAN86

M50405 -UN-31AUG88

3. Put O-ring and thrust washer over input shaft.



M50404  
-UN-31AUG88

M21,5015S,BB -19-23JAN86

4. Install pinion gear (A) and snap ring.



M50403  
-UN-31AUG88

M21,5015S,BC -19-23JAN86

### INSTALL INTERNAL COMPONENTS

1. Install differential assembly in case.
2. Install gear assembly in case.



M50401  
-UN-31AUG88

M21,5015S,BD -19-23JAN86

## 5-Speed Transaxle/Transaxle

3. Make sure tabs on bushings (A) are rotated into notch in case.

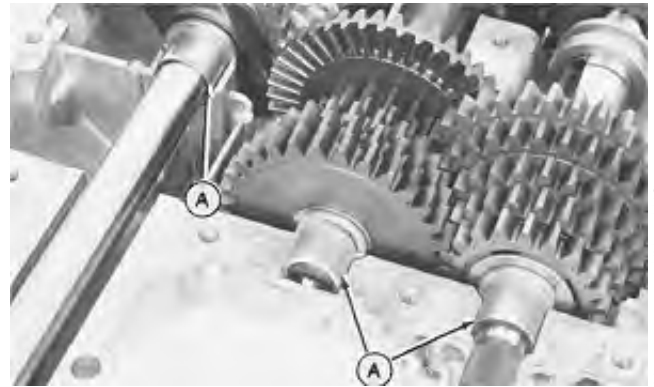

Right Side

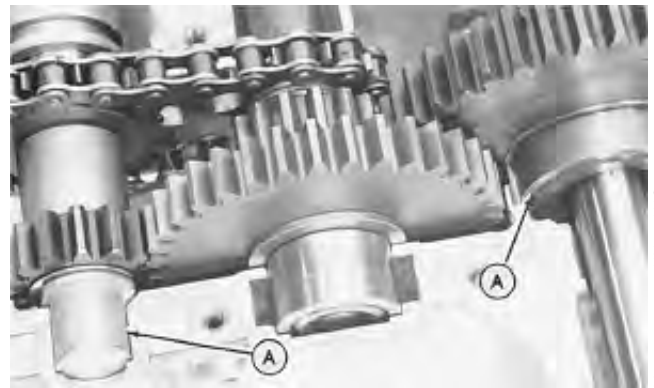

Left Side

M50422 -UN-31AUG88  
M50423 -UN-31AUG88  
M21,5015S,BE -19-23JAN86

4. Install shifter fan, putting pins in groove on shifter collar.

5. Put approximately 1.0 L (2.2 pt) of John Deere High Temperature Grease around gears in transaxle case.



M50400 -UN-31AUG88  
M21,5015S,BF -19-27MAR86

**NOTE:** New transaxle cases have untapped bolt holes. Use the self-tapping cap screws when assembling.

6. Install cover. Install and tighten 17 cap screws to 12 N·m (100 lb-in.).



M50399 -UN-31AUG88  
M21,5015S,A1 -19-18APR88



## 5-Speed Transaxle/Transaxle

7. Install detent ball, spring, and Allen-head screw. Tighten screw one turn below flush with case cover.



M21,5015S,BH -19-23JAN86

M50398  
-UN-31AUG88

### INSTALL EXTERNAL TRANSAXLE PARTS

1. Install puck, disk, and brake assembly. Install and tighten cap screws and washers.



M21,5015S,BI -19-31DEC85

M50397  
-UN-03JAN90

2. Install neutral start switch.



M21,5015S,BJ -19-31DEC85

M50262  
-UN-22DEC89

3. Install key, transaxle drive sheave, and snap ring (A).
4. Install support and fasten with two self tapping screws.

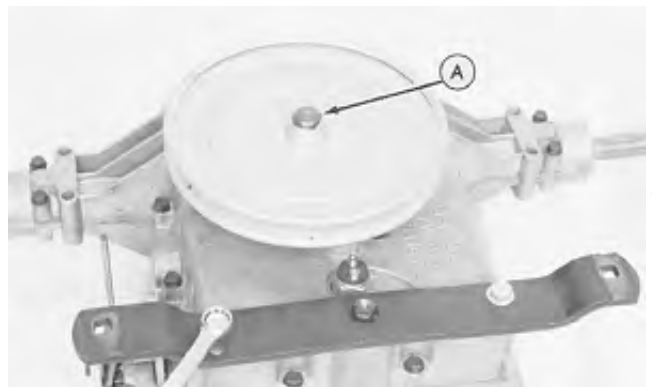

M21,5015S,BK -19-31DEC85

M50261  
-UN-31AUG88

## INSTALL TRANSAXLE

1. Position transaxle under tractor. Lift transaxle and fasten with two U-bolts and nuts.

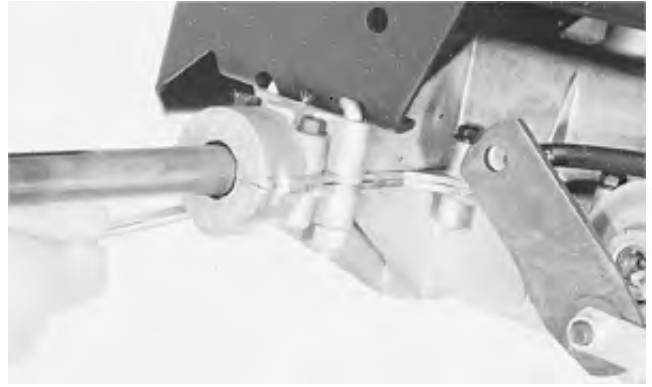

M50260  
-UN-22DEC89

M21,5015S,BL -19-31DEC85

2. Install shift arm, washer, and cap screw.



M50259  
-UN-22DEC89

M21,5015S,BM -19-31DEC85

*NOTE: Cap screws for support also fasten belt guide.*

3. Install two cap screws and nuts.



M50258  
-UN-22DEC89

M21,5015S,BN -19-31DEC85

4. Connect brake linkage.
5. Connect wire (A) to neutral start switch.
6. Install rear wheels. (See Replace Rear Wheels in Section 50, Group 05.)
7. Adjust traction drive belt. (See Adjust Traction Drive Belt for Models 130, 160, and 180 in Section 50 Group 05.)
8. Adjust brakes. (See Adjust Brakes in Section 60, Group 15.)
9. Adjust transmission control lever. (See Adjust Transmission Control Lever in this group.)

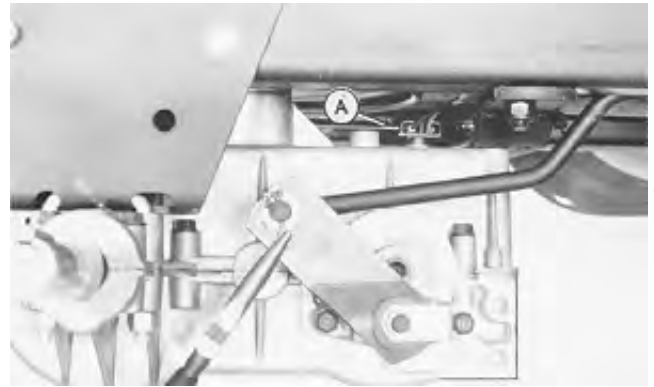

M50257 -UN-22DEC89

M21,5015S,BO -19-31DEC85

### ADJUST TRANSMISSION CONTROL LEVER—130, 160 AND 180

1. Check control lever adjustment. It must be centered in the neutral slot and 1 mm (0.040 in.) (A) from edge of slot.



M50264 -UN-22DEC89

M21,5015S,A2 -19-16MAY88

2. To adjust lever, stop engine and engage park brake. Put transmission control lever in neutral position.
3. Loosen nuts (A). Use nuts (A) to move control lever forward or rearward to center lever in slot. Tighten nuts (A).
4. Loosen nuts and turn stop screw (B) until control lever is 1 mm (0.040 in.) from edge of slot. Tighten nuts.

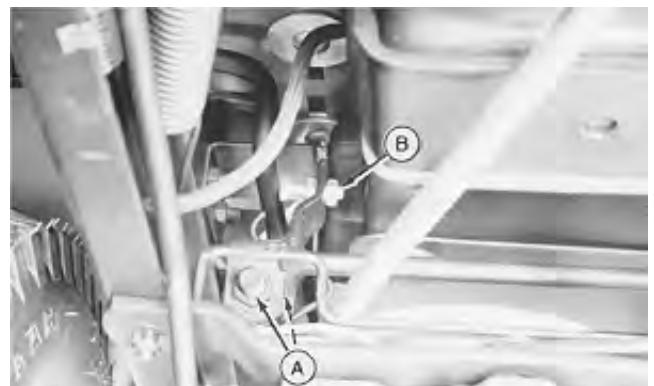

M50265 -UN-22DEC89

M21,5015S,A3 -19-16MAY88

50  
15  
18

**ESSENTIAL TOOLS**

*NOTE: Order tools from your SERVICE-GARD™ Catalog. Some tools may be available from a local supplier.*

O53,TOOLS -19-13JUL88

Seal Remover . . . . . JDG213

M51849 -UN-26SEP88

Used to remove control shaft seal.

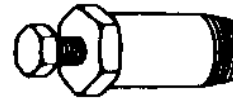

53M,JDG213 -19-18APR88

Seal Installer . . . . . JDG214

M51850 -UN-26SEP88

Used to install control shaft seal.



53M,JDG214 -19-18APR88

**SERVICE EQUIPMENT AND TOOLS**

*NOTE: Order tools from your SERVICE-GARD™ Catalog. Some tools may be available from a local supplier.*

Name	Use
11/32-in. Drill Bit	Remove Dowel Pin
5/16-18 NC Tap	Remove Check Valve Bodies

M21,5020S,ZB -19-22JAN86

**OTHER MATERIAL**

Number	Name	Use
	SAE 30 Engine Oil	Fill transmission.
	SAE 90 Oil	Fill differential.

M21,5020S,A16 -19-16MAY88

50  
20  
1

## SERVICE PARTS KITS

The following kits are available through your parts catalog: Motor Rotor Assembly Kit

Pump Rotor Assembly Kit

M21,5020S,ZD -19-22JAN86

## REMOVE DIFFERENTIAL AND HYDROSTATIC TRANSMISSION ASSEMBLY

*NOTE: This service procedure is for the following machines: 165, 175 and 185 (S.N. —475000).*

1. Remove mower.
2. Put transmission control lever in neutral.
3. Drain differential.
4. Remove rear wheels. (See Section 50, Group 05.)
5. Remove fuel tank. (See Section 30, Group 05.)



M50239 -UN-22DEC89

M21,5020S,A1 -19-13MAY88

6. Remove heat shield.



M50240 -UN-22DEC89

M21,5020S,B -19-22JAN86

7. Remove two nuts (A).



M21,5020S,C -19-22JAN86

M50242 -UN-22DEC89

8. Remove transmission linkage and key (A) from transmission.

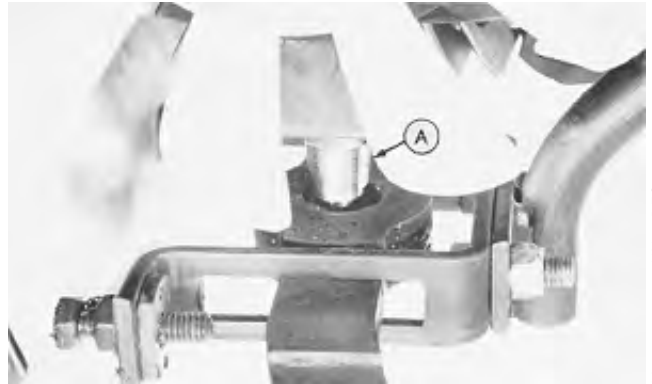

M21,5020S,D -19-22JAN86

M50243 -UN-22DEC89

9. Loosen three cap screws fastening differential to frame.

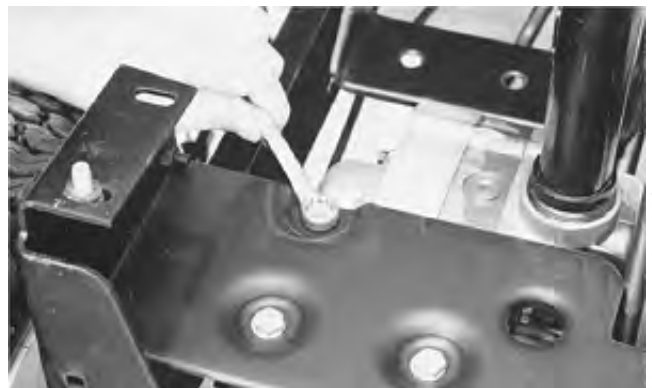

M21,5020S,E -19-22JAN86

M50241 -UN-22DEC89

10. Disconnect brake linkage.



M21,5020S,F -19-22JAN86

M50244 -UN-22DEC89

11. Remove four nuts fastening differential to frame.



M21,5020S,G -19-22JAN86

M50245 -UN-22DEC89

12. Remove three cap screws and lower differential and transmission assembly.

13. Remove traction drive belt from transmission sheave. Remove differential and transmission assembly.



M21,5020S,H -19-22JAN86

M50246 -UN-22DEC89

## REMOVE TRANSMISSION—EATON

1. Remove four cap screws and washers.
2. Remove transmission and gasket from differential.



M21,5020S,A2 -19-18APR88

M50247 -UN-22DEC89

## REPLACE SHAFT SEAL

**IMPORTANT:** Clean exterior of transmission to prevent contamination.

1. Drain transmission fluid.

**IMPORTANT:** DO NOT damage control shaft or seal counterbore when removing seal.

2. Remove seal using JDG213 Seal Remover.



M21,5020S,A3 -19-18APR88

M50368 -UN-03JAN90



3. Lubricate inner surface of seal.
4. Press seal into position over shaft with JDG214 Seal Installer.



M21,5020S,A4 -19-18APR88

M50369 -UN-03JAN90

## REMOVE AND INSPECT FAN AND SHEAVE

1. Remove and inspect fan. Replace if damaged.



M21,5020S,L -19-22JAN86

M50248 -UN-22DEC89

2. Remove two Allen-head screws and transmission sheave.
3. Inspect sheave. Replace if damaged.



M21,5020S,M -19-22JAN86

M50249 -UN-22DEC89

## DISASSEMBLE TRANSMISSION—EATON

*NOTE: Oil reservoir has a left-hand thread.*

1. Drain transmission at reservoir. Remove reservoir.



M21,5020S,A5 -19-18APR88

M50250 -UN-22DEC89

**IMPORTANT:** During assembly, cover and body must be in their original positions or transmission output rotation will be reversed.

2. Make line across cover and body to mark correct positions for assembly.
3. Remove two Allen-head screws.



M21,5020S,O -19-22JAN86

M50341 -UN-22DEC89

4. Rotate transmission so that cover (A) is on top of body (B). Loosen cover. If cover does not separate easily from body, tap cover and body with plastic hammer.

**IMPORTANT:** DO NOT allow rotor assembly to lift with cover. The ball piston assembly MUST remain intact as the ball pistons are matched to the rotor bores.

5. Lift cover off body.

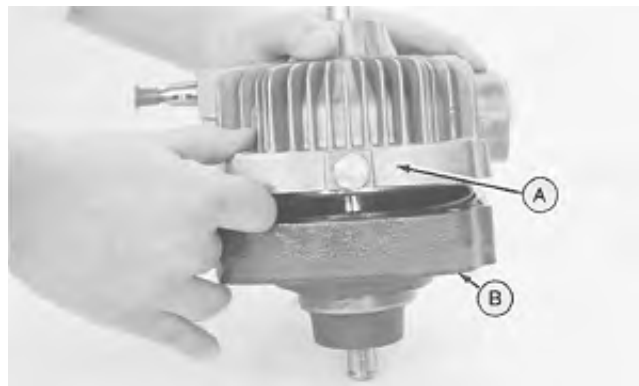

M21,5020S,P -19-22JAN86

M50342 -UN-22DEC89

6. For proper ball positioning when assembling, put numbers on rotor before removal.

**IMPORTANT:** Use special care when removing rotor from body. Ball pistons MUST remain in place as they are matched to the rotor bores.

7. Use a wide rubber band to hold pistons in place. Remove rotor.



M21,5020S,Q -19-27MAR86

M50343 -UN-22DEC89

8. Remove retaining ring from output shaft.
9. Remove gear (A).



M21,5020S,R -19-22JAN86

M50344 -UN-22DEC89

50  
20  
6

10. Remove key (A) and spacer (B).
11. Remove output shaft (C).



M21,5020S,S -19-22JAN86

M50345 -UN-22DEC89

12. Remove retaining ring.
13. Remove bearing (A) and oil seal (B).

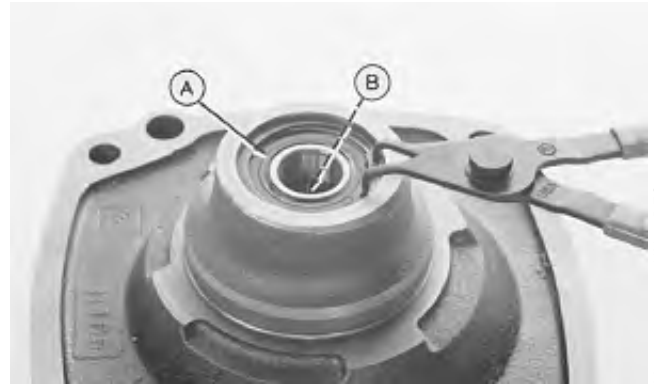

M21,5020S,T -19-22JAN86

M50346 -UN-22DEC89

14. Remove retaining ring from input shaft.
15. Remove key (A) from shaft.



M21,5020S,U -19-22JAN86

M50347 -UN-22DEC89

16. Remove dump valve shaft.

**IMPORTANT: DO NOT allow rotor assembly to lift with pivot pin assembly. The ball piston assembly MUST remain intact as the ball pistons are matched to the rotor bores.**

17. Remove pivot pin assembly (A).



M21,5020S,V -19-27MAR86

M50348 -UN-03JAN90

18. For proper ball positioning when assembling, put numbers on rotor before removal.

**IMPORTANT: Use special care when removing the rotor from the cover. The ball pistons MUST remain in place as they are matched to the rotor bores.**

19. Use a wide rubber band to hold the pistons in place. Remove rotor.

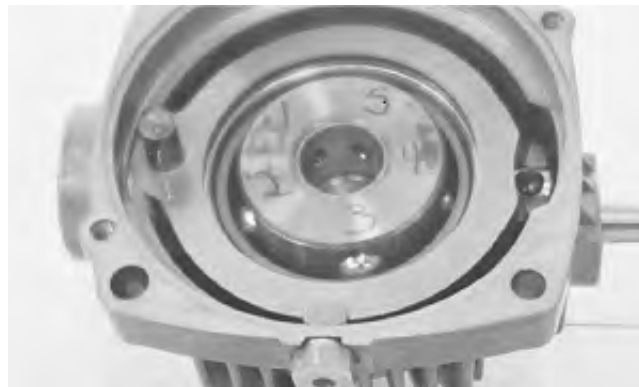

M21,5020S,W -19-22JAN86

M50349 -UN-22DEC89

20. Remove cam ring.



M21,5020S,X -19-22JAN86

M50350 -UN-22DEC89

21. Remove button (A).

22. Remove input shaft and bearing assembly (B).

23. Remove oil seal (C).

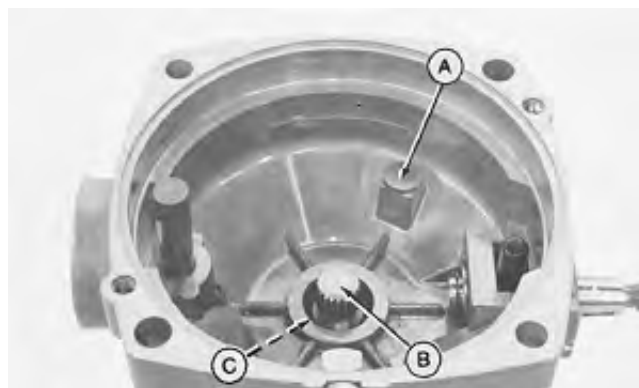

M21,5020S,Y -19-22JAN86

M50351 -UN-22DEC89

### INSPECT BODY AND OUTPUT SHAFT ASSEMBLY

1. Inspect body (A). Replace if cracked or broken.

2. Inspect bearing (B) and output shaft (C). Replace if damaged.

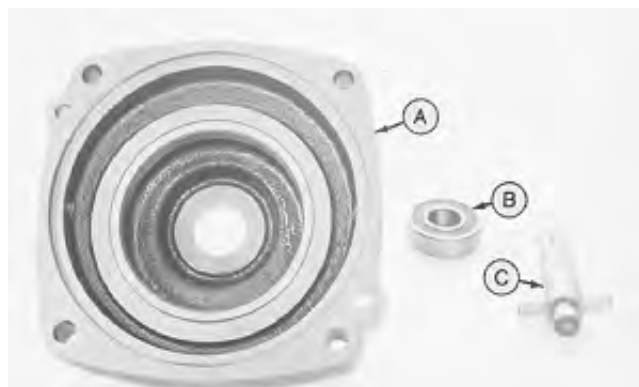

M21,5020S,Z -19-22JAN86

M50367 -UN-03JAN90

## INSPECT COVER

1. Inspect cover, especially around control shaft (A). Replace cover if cover is broken or cracked.



M21,5020S,AA -19-27MAR86

M50352  
-UN-03JAN90

## INSPECT INPUT SHAFT ASSEMBLY

1. Inspect retaining ring (A). Replace if damaged.

*NOTE: Do not separate bearing from shaft unless damage is found.*

2. Inspect input shaft (B) and bearing (C).
3. If damage is found, remove snap ring (D) and remove bearing from shaft.
4. Install bearing and new snap ring on shaft.

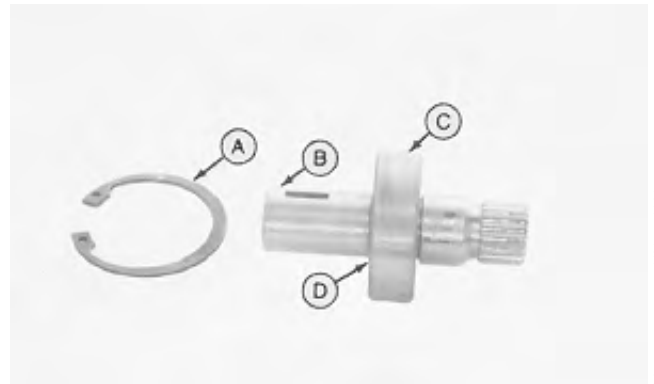

A—Retaining Ring  
B—Input Shaft  
C—Bearing  
D—Snap Ring

M21,5020S,AB -19-27MAR86

M50356  
-UN-03JAN90

## INSPECT CONTROL SHAFT ASSEMBLY

1. Remove and discard oil seal (A) from control shaft assembly. (See Replace Shaft Seal in this group.)

*NOTE: Do not remove dowel pin or control shaft unless damaged.*

2. Inspect dowel pin (B) and control shaft (C). Replace if damaged.

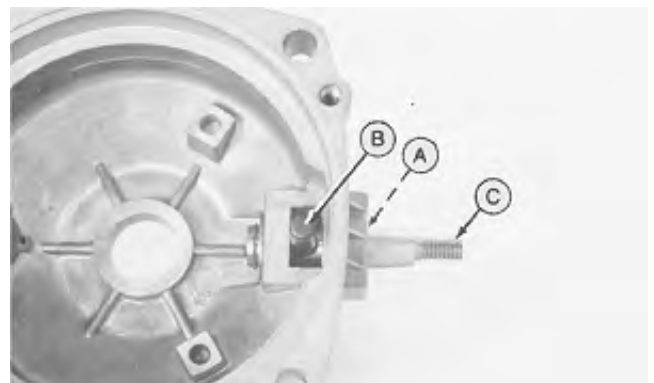

M21,5020S,AC -19-22JAN86

M50353  
-UN-03JAN90

## REPLACE CONTROL SHAFT ASSEMBLY

*NOTE: Do not remove dowel pin and control shaft unless one has been damaged.*

1. Measure distance (A) between center of dowel pin and end of control shaft.

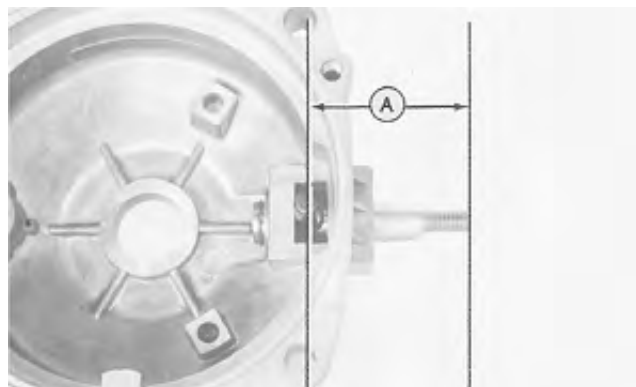

M21,5020S,AD -19-22JAN86

M50354 -UN-03JAN90

2. Use this dimension (A) to locate dowel pin from outside of cover.
3. Drill 11/32-in. diameter hole (B) in line with center of control shaft and dowel pin.
4. Remove dowel pin using a punch through the drilled hole.

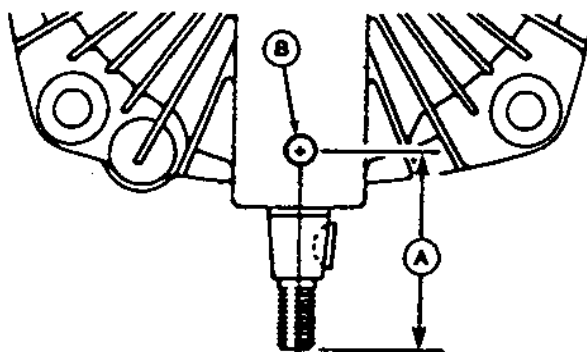

M21,5020S,AE -19-27MAR86

M50355 -UN-26APR89

5. Remove retaining ring (A) and washer (B).
6. Remove control shaft (C).
7. Install a 1/8-in. countersunk hex-head pipe plug in drilled hole. Pipe plug must be even with outside surface of case.
8. Lubricate new control shaft. Install in cover.
9. Install washer and retaining ring.

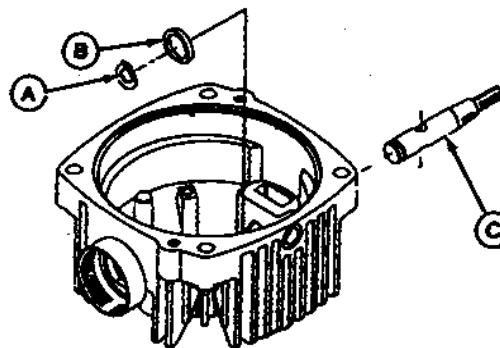

M21,5020S,AF -19-27MAR86

M50356 -UN-26APR89

10. Position keyway (A) as shown before install doweling pin.
11. Install new dowel pin (B) through shaft until 28.6 mm (1.13 in.) of pin extends above shaft.
12. Install new oil seal (C). (See Replace Shaft Seal in this group.)

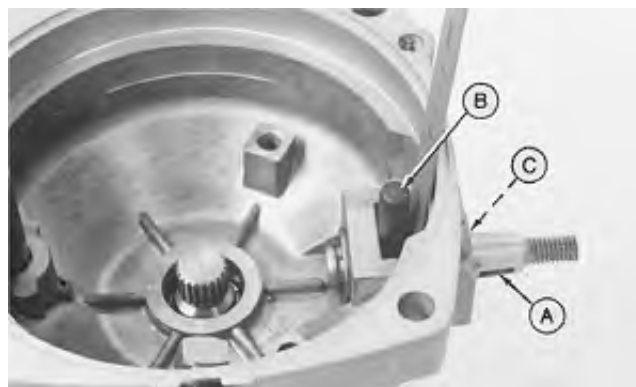

M21,5020S,AG -19-22JAN86

M50357 -UN-03JAN90

50  
20  
10

## INSPECT ROTOR ASSEMBLIES

1. Inspect for burrs or scoring in bore (A).
2. Inspect ball pistons (B) and springs (C).
3. Check rotor bushings (D) for wear and scoring.
4. Apply a thin film of oil on ball pistons. Put corresponding ball piston in numbered hole of rotor. Close inner port of rotor with finger. Push on ball with thumb. Should feel spongy and not stick.
5. Repeat Step 4 for each ball piston. If one ball in rotor set rolls or does not FLOAT in rotor, replace complete rotor assembly.
6. If any irregularities are found, replace the rotor assembly.
7. Install springs and ball pistons in their original positions. Secure with a wide rubber band.

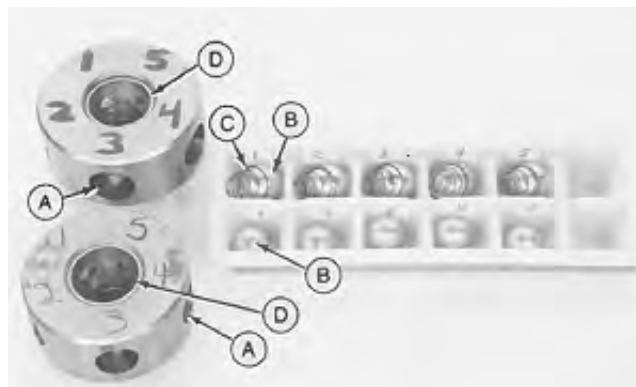

A—Bore  
B—Ball Pistons  
C—Springs  
D—Bushings

M21,5020S,A6 -19-18APR88

M50364 -UN-03JAN90

50  
20  
11

## INSPECT PUMP RACE

1. Inspect line where ball pistons contact pump race.
2. If irregularities found, replace race. Install flush to 0.25 mm (0.010 in.) recessed from edge of cam.



M21,5020S,A7 -19-18APR88

M50365 -UN-03JAN90

## INSPECT MOTOR RACE

1. Inspect line (A) where ball pistons contact motor race. Replace race if not smooth or free of irregularities.



M21,5020S,AJ -19-22JAN86

M50366 -UN-03JAN90

## INSPECT PIVOT PIN ASSEMBLY

1. Remove and inspect dump valve bracket and spring assembly (A). Replace if damaged.
2. Inspect both pivot pin assembly journals (B). Replace assembly if any irregularities are found.
3. Inspect dampening pistons (C). Replace if scored. (See Replace Dampening Pistons in this group.)
4. Shake pivot pin assembly to inspect check balls (D). If check balls do not rattle, check valve assembly is faulty. Replace valve assembly. (See Replace Check Valve Assembly in this group.)

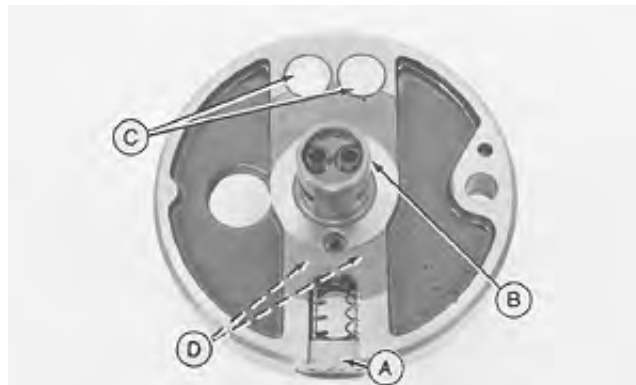

A—Dump Valve Assembly  
 B—Journals  
 C—Dampening Pistons  
 D—Check Balls

M21,5020S,AK -19-22JAN86

M50359 -UN-03JAN90

## REPLACE DAMPENING PISTONS

**IMPORTANT: Do not hit piston pin assembly journals or assembly will be damaged.**

1. Firmly tap outside edge of piston pin assembly on work surface to dislodge pistons.
2. If piston did not come out, see adhesive to fasten cap screw to it. Pull piston from the bore.



M21,5020S,AL -19-22JAN86

M50360 -UN-03JAN90

3. Remove back-up rings (A) and O-rings (B) from pistons (C).
4. Install new back-up rings and O-rings on pistons.
5. Lubricate outer surface of pistons. Push pistons into bores with smooth face up.

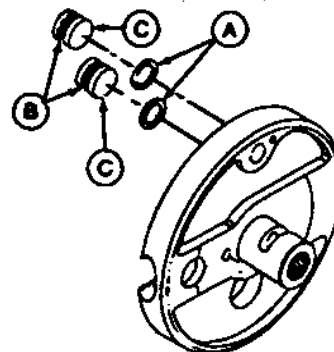

M21,5020S,AM -19-27MAR86

M50361 -UN-26APR89

50  
20  
12



## REPLACE CHECK VALVE ASSEMBLY

1. Remove coil pin (A).



M50362 -UN-03JAN90

M21,5020S,AN -19-22JAN86

2. Tap holes in check valve bodies (A) using a 5/16-18 NC tap (D).

3. Pull check valve bodies out using a long cap screw or threaded puller (E).

4. Remove and inspect check balls (B) and retaining rings (C). Replace any defective parts.

5. Install retaining rings and check balls.

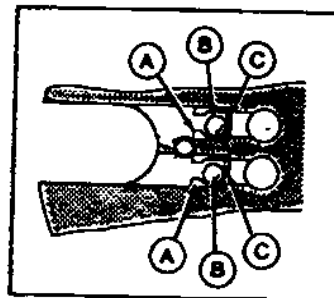

**IMPORTANT: To prevent retaining rings from dislodging, do not DRIVE in check valve bodies.**

6. Install new check valve bodies. Be sure to allow for coil pin clearance.

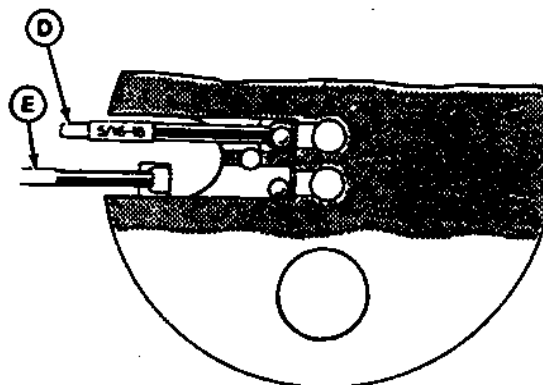

- A—Check Valve Body
- B—Check Ball
- C—Retaining Ring
- D—Tap
- E—Puller

50  
20  
13

M50363 -UN-26APR89

M21,5020S,AO -19-27MAR86

7. Install coil pin (A).

8. Install dump valve bracket (B) and springs (C).

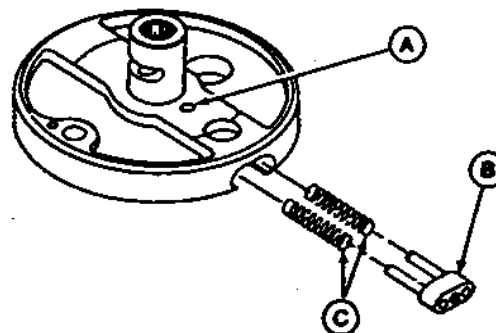

M50370 -UN-26APR89

M21,5020S,A8 -19-18APR88

## ASSEMBLE TRANSMISSION—EATON

**IMPORTANT:** Excessive pressing or driving of oil seal will damage rubber portion of seal. Use care not to damage seal when installing.

1. Lubricate inner surface of new seal using clean lubricant. Install seal (C).
2. Install input shaft and bearing assembly (B).
3. Install button (A).



M50351 -UN-22DEC89

M21,5020S,A9 -19-18APR88

4. Install cam ring.

50  
20  
14

5. Check cam ring movement. Cam ring must move freely from stop to stop. If binding occurs at either stop, rotate cam ring insert 180°. Check movement again.



M50350 -UN-22DEC89

M21,5020S,AR -19-22JAN86

**IMPORTANT:** Use special care when installing rotor in cover. Ball pistons **MUST** remain in place as they are matched to the rotor bores.

6. Align internal spline of pump rotor with external spline on input shaft. Install rotor. Remove rubber band.



M50349 -UN-22DEC89

M21,5020S,AS -19-22JAN86

**NOTE:** Do not force rotor assembly on pivot pin assembly. Rotor assembly must turn freely. If not, recheck installation.

7. Install pivot pin assembly (A).
8. Install dump valve shaft. Tighten to 4 N·m (30 lb-in.).



M21,5020S,A10 -19-18APR88

M50348 -UN-03JAN90

9. Install retaining ring to cover.

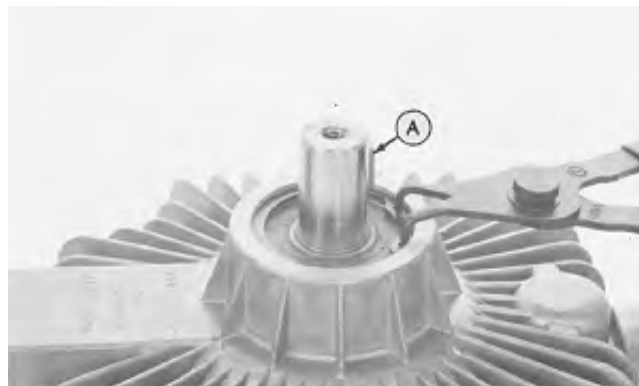

M21,5020S,AU -19-22JAN86

M50347 -UN-22DEC89

**IMPORTANT:** Excessive pressing or driving of oil seal will damage rubber portion of seal. Use care not to damage seal when installing.

10. Lubricate inner surface of new seal using clean lubricant. Install seal (A) with rubber lip toward counterbore in body.



M21,5020S,AV -19-22JAN86

M50371 -UN-03JAN90

**IMPORTANT:** Use care to avoid damage to oil seal when installing output shaft.

11. Install output shaft in body so that cross pin (A) fits into groove (B).

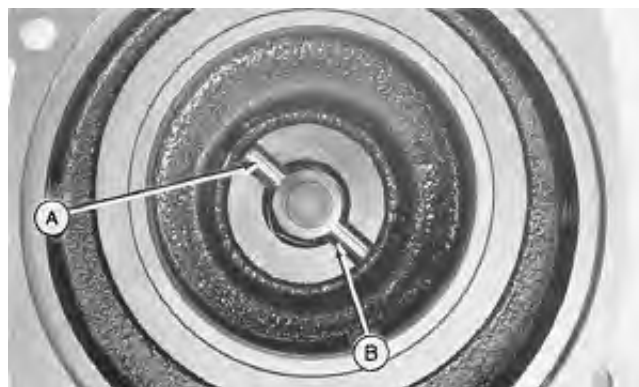

M21,5020S,AW -19-22JAN86

M50372 -UN-03JAN90

12. Support output shaft (A) from below so that cross pin of shaft is tight against body.

13. Install bearing (B) and retaining ring (C).

14. Check that output shaft rotates freely by hand. If not, recheck installation.

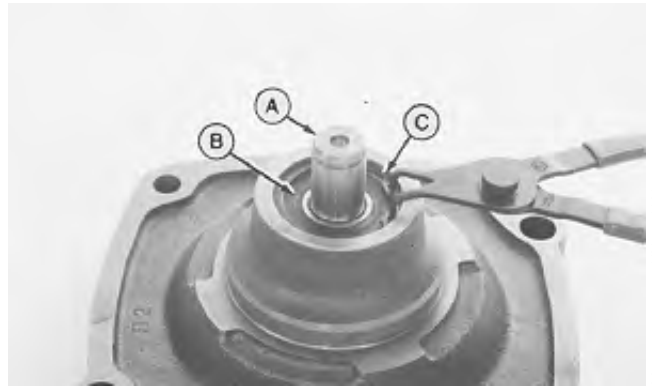

M21,5020S,AX -19-22JAN86

M50373 -UN-03JAN90

15. Install washer (B).

16. Install key (A) in shaft (C).



M21,5020S,AY -19-22JAN86

M50345 -UN-22DEC89

17. Install gear (A) and retaining ring.



M21,5020S,AZ -19-22JAN86

M50344 -UN-22DEC89

**IMPORTANT: Use special care when installing rotor in body. Ball pistons MUST remain in place as they are matched to the rotor bores.**

18. Align slot in rotor assembly with cross pin on output shaft.

19. Install rotor assembly and remove rubber band, if used.



M21,5020S,BA -19-22JAN86

M50343 -UN-22DEC89

50  
20  
16

**IMPORTANT:** Do not force rotor assembly on pivot pin assembly. Rotor must turn freely by hand.

**Cover and body must be assembled in their original positions or transmission output rotation will be reversed.**

20. Install cover (A) to body (B).

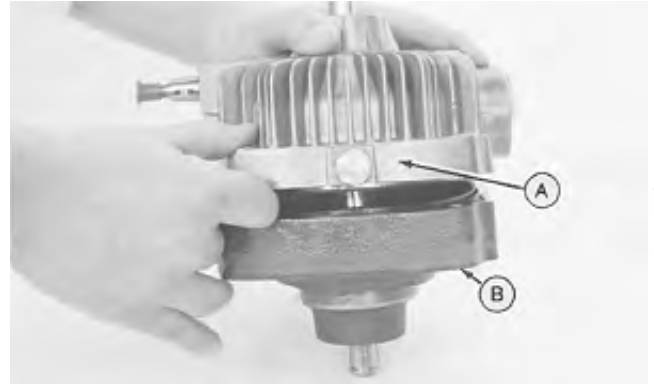

M21,5020S,BB -19-22JAN86

M50342 -UN-22DEC89

21. Align body and cover marks (A).

22. Install two Allen-head screws and tighten to 20 N-m (177 lb-in.).



M21,5020S,BC -19-22JAN86

M50341 -UN-22DEC89

23. Install new seal ring to oil reservoir recess (A) in cover.



M21,5020S,BD -19-22JAN86

M50251 -UN-22DEC89

*NOTE: Oil reservoir has left-hand thread.*

24. Install oil reservoir and tighten to 14 N-m (124 lb-in.).



M21,5020S,A11 -19-18APR88

M50250 -UN-22DEC89

## INSTALL FAN AND SHEAVE

1. Install sheave to input shaft and fasten with two Allen-head screws.



M21,5020S,BF -19-22JAN86

M50249  
-UN-22DEC89

2. Install fan on input shaft.



M21,5020S,BG -19-22JAN86

M50248  
-UN-22DEC89

50  
20  
18

## FILL TRANSMISSION RESERVOIR

1. Remove plug (A) and reservoir cap (B).
2. Fill reservoir (C) with recommended engine oil until fluid flows from vent.
3. Rotate both input and output shafts to release air trapped in transmission. Add oil to reservoir until oil re-appears at vent, then install and tighten plug.
4. Refill reservoir to cold level FULL mark on units with dipstick or until oil is 140 mm (5.50 in.) below top of reservoir. Replace reservoir cap.

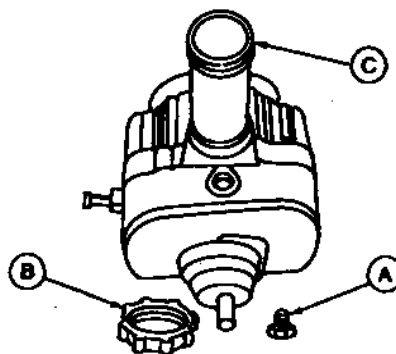

M21,5020S,A12 -19-13MAY88

M50374  
-UN-26APR89

## INSTALL TRANSMISSION—EATON

1. Install gasket and transmission on differential.
2. Install four cap screws and washers.



M21,5020S,A13 -19-18APR88

M50247  
-UN-22DEC89

3. Fill differential assembly with 0.7 L (1.5 pt) of SAE 90 oil.

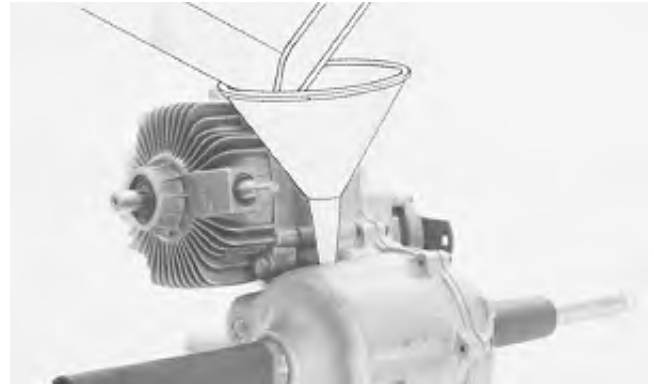

M21,5020S,BJ -19-22JAN86

M50396  
-UN-03JAN90

## INSTALL DIFFERENTIAL AND HYDROSTATIC TRANSMISSION ASSEMBLY

1. Position differential and hydrostatic transmission assembly under frame. Install traction drive belt on transmission sheave.
2. Lift right side of rear axle and install strap, nuts, and washers.
3. Lift left side of rear axle and install strap, nuts, and washers.



M21,5020S,BK -19-22JAN86

M50460  
-UN-03JAN90

4. Install three washers and cap screws. Tighten all differential and hydrostatic transmission mounting hardware.



M21,5020S,BL -19-22JAN86

M50246 -UN-22DEC89

5. Connect brake linkage.



M21,5020S,BM -19-22JAN86

M50244 -UN-22DEC89

6. Install key (A) and transmission linkage.

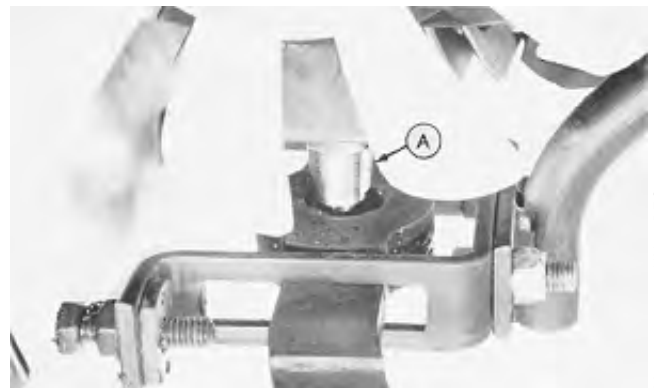

M21,5020S,BN -19-22JAN86

M50243 -UN-22DEC89

7. Tighten nuts (A).



M21,5020S,BO -19-22JAN86

M50242 -UN-22DEC89

50  
20  
20



8. Install heat shield.
9. Install fuel tank. (See Section 30, Group 05.)
10. Install rear wheels. (See Section 50, Group 05.)
11. Remove blocking from tractor.

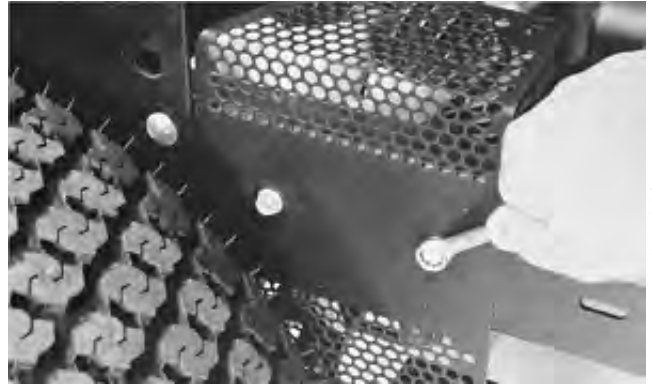

M50240 -UN-22DEC89

M21,5020S,A14 -19-18APR88

12. Check oil level in differential. Oil should be a short distance below plug hole.
13. Adjust transmission. (See Section 250.)
14. Install mower.



M32896 -UN-17AUG89

M21,5020S,A15 -19-18APR88

50  
20  
22

## OTHER MATERIAL

Number	Name	Use
	SAE 10W30 Oil	Fill Hydrostatic System

M21,5021S,A1 -19-18APR88

## SEPARATE DIFFERENTIAL AND TRANSMISSION

*NOTE: This service procedure is for the following machines: 185 (S.N. 475001— ).*

1. Clean transaxle assembly and drain oil.
2. Remove items (A—F).

A—Fan  
B—Hose  
C—Drain Plug  
D—Tow Linkage  
E—Transmission  
F—Sheave

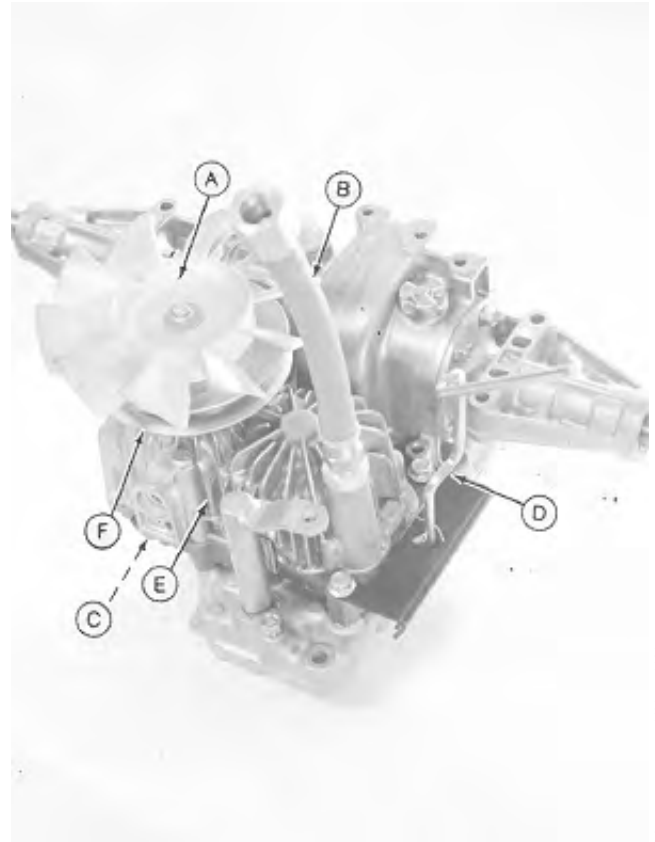

M48169 -UN-08JAN90  
M21,5021S,A2 -19-23MAY88

## DISASSEMBLE TRANSMISSION—SUNDSTRAND

*NOTE: This service procedure is for the following machines: 185 (S.N. 475001— ).*

1. Remove center section (M) from transmission housing assembly (E).
2. Remove gasket (D).
3. Remove items (A—N) from center section.

- A—Check Valve (2 used)
- B—Plug with Packing (2 used)
- C—Plug with Packing
- D—Gasket
- E—Transmission Housing Assembly
- F—Bearing
- G—Dowel Pin (2 used)
- H—Needle Bearing
- I—By-Pass Valve Assembly
- J—Cap Screw (4 used)
- K—Name Plate
- L—Seal
- M—Center Section
- N—Cap Screw (4 used)

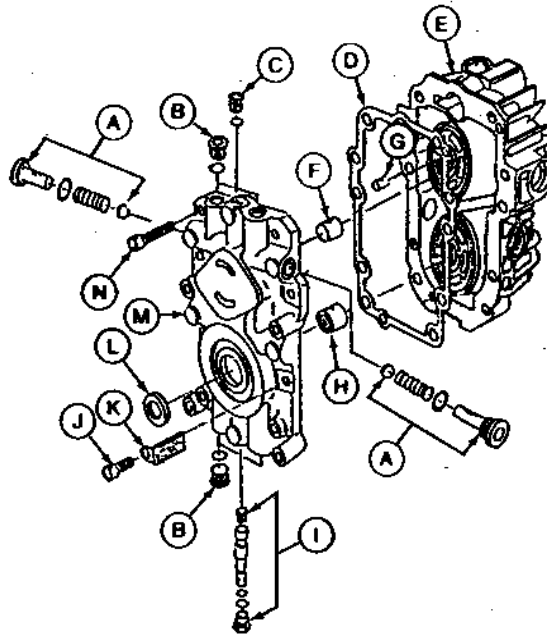

M21,5021S,A3 -19-13MAY88

M46114 -UN-31AUG88

**IMPORTANT: Do not nick or scratch lapped surface of cylinder blocks. Piston-to-bore relationship need not be maintained; keep pump and motor components separate, they are not interchangeable.**

4. Remove motor cylinder block and shaft assembly (H—K) from the housing assembly (G).
5. Remove pump cylinder block and shaft assembly (A—L).

- A—Retaining Ring
- B—Seal
- C—Spacer
- D—Ball Bearing
- E—Retaining Ring (4 used)
- F—Pump Shaft
- G—Housing Assembly
- H—Thrust Ball Bearing Assembly
- I—Motor Shaft
- J—Washer (2 used)
- K—Motor Cylinder Block
- L—Pump Cylinder Block
- M—Spring
- N—Thrust Plate
- O—Thrust Roller

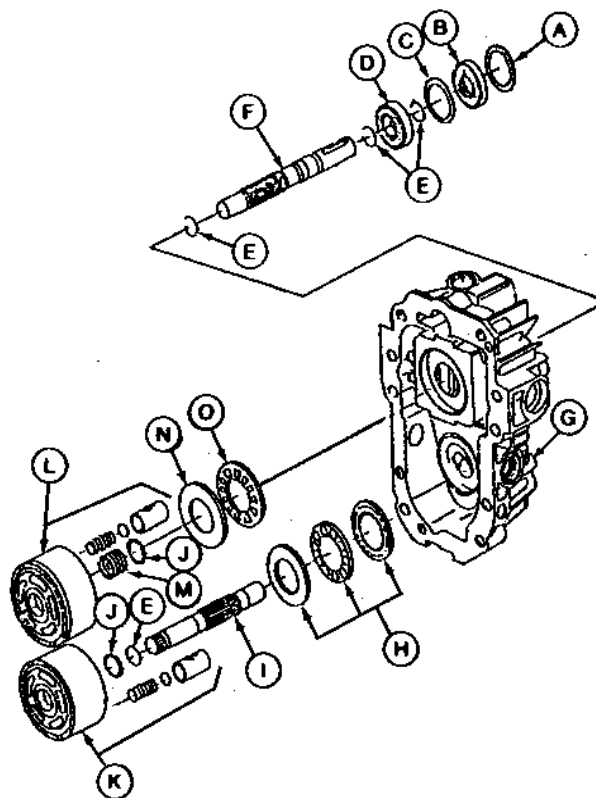

M21,5021S,A4 -19-18APR88

M46115 -UN-31AUG88

6. Remove items (A—J) from housing assembly (D).

- A—Plug with Packing (3 used)
- B—Filter Assembly
- C—Fitting with Packing
- D—Housing Assembly
- E—Swashplate
- F—Cradle Bearing (2 used)
- G—Seal
- H—Bearing
- I—Trunion Arm
- J—Slot Guide

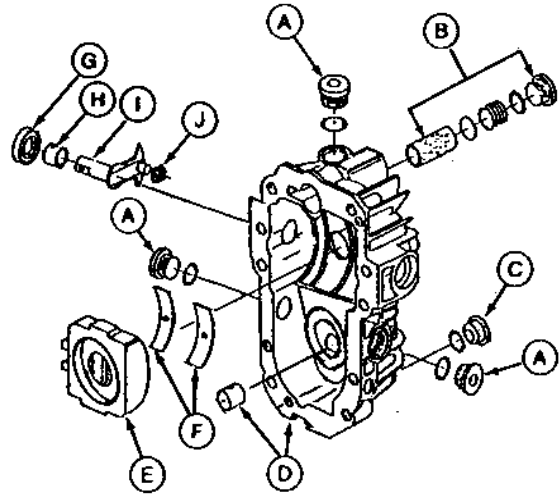

M21,5021S,A5 -19-18APR88

M46116  
-UN-31/AUG88

50  
21

## ASSEMBLE TRANSMISSION—SUNDSTRAND

*NOTE: This service procedure is for the following machines: 185 (S.N. 475001— ).*

1. Install items (A—J) into housing assembly (D).

- A—Plug with Packing (3 used)
- B—Filter Assembly
- C—Fitting with Packing
- D—Housing Assembly
- E—Swashplate
- F—Cradle Bearing (2 used)
- G—Seal
- H—Bearing
- I—Trunion Arm
- J—Slot Guide

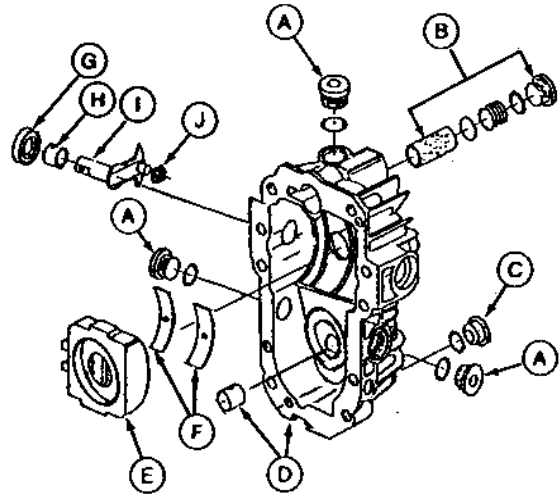

M21,5021S,A6 -19-13MAY88

M46116  
-UN-31/AUG88

M46116

**IMPORTANT: Do not nick or scratch lapped surface of cylinder blocks. Piston-to-bore relationship need not be maintained; keep pump and motor components separate, they are not interchangeable.**

2. Install pump cylinder block and shaft assembly (A—L) into the housing assembly (G).

3. Install motor cylinder block and shaft assembly (H—K).

- A—Retaining Ring
- B—Seal
- C—Spacer
- D—Ball Bearing
- E—Retaining Ring (4 used)
- F—Pump Shaft
- G—Housing Assembly
- H—Thrust Ball Bearing Assembly
- I—Motor Shaft
- J—Washer (2 used)
- K—Motor Cylinder Block
- L—Pump Cylinder Block
- M—Spring
- N—Thrust Plate
- O—Thrust Roller

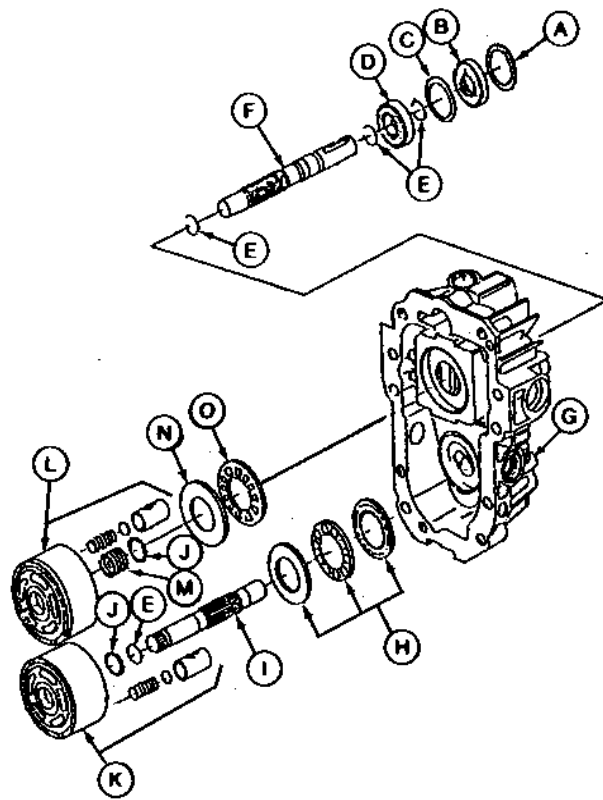

M21,5021S,A7 -19-13MAY88

M46115 -UN-31AUG88

4. Install items (A—N) into center section (M).

5. Install new gasket (D).

6. Install center section onto transmission housing assembly (E). Tighten cap screws (J and N) to 17 N·m (150 lb-in.).

- A—Check Valve (2 used)
- B—Plug with Packing (2 used)
- C—Plug with Packing
- D—Gasket
- E—Transmission Housing Assembly
- F—Bearing
- G—Dowel Pin (2 used)
- H—Needle Bearing
- I—By-Pass Valve Assembly
- J—Cap Screw (4 used)
- K—Name Plate
- L—Seal
- M—Center Section
- N—Cap Screw (4 used)

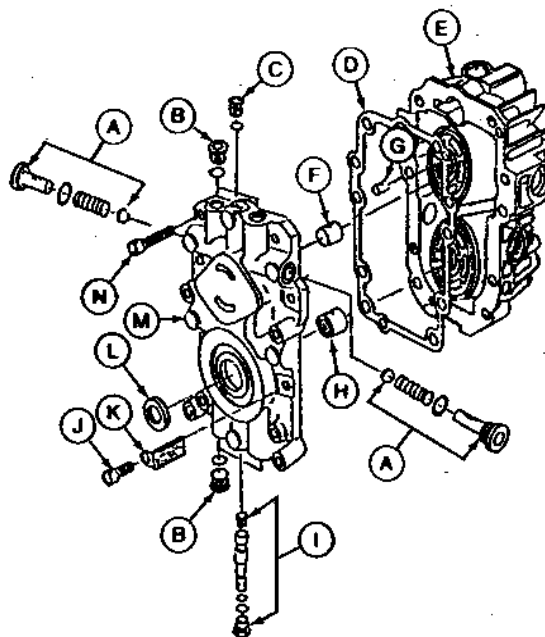

M21,5021S,A8 -19-18APR88

M46114 -UN-31AUG88

50  
21  
4

## ASSEMBLE DIFFERENTIAL AND TRANSMISSION

1. Install items (A—F).
2. Tighten drain plug (C) to 15 N·m (130 lb-in.).
3. After installing the complete transaxle into the machine, bleed the hydrostatic system. (See Group 21 in this section.)

A—Fan  
 B—Hose  
 C—Drain Plug  
 D—Tow Linkage  
 E—Transmission  
 F—Sheave

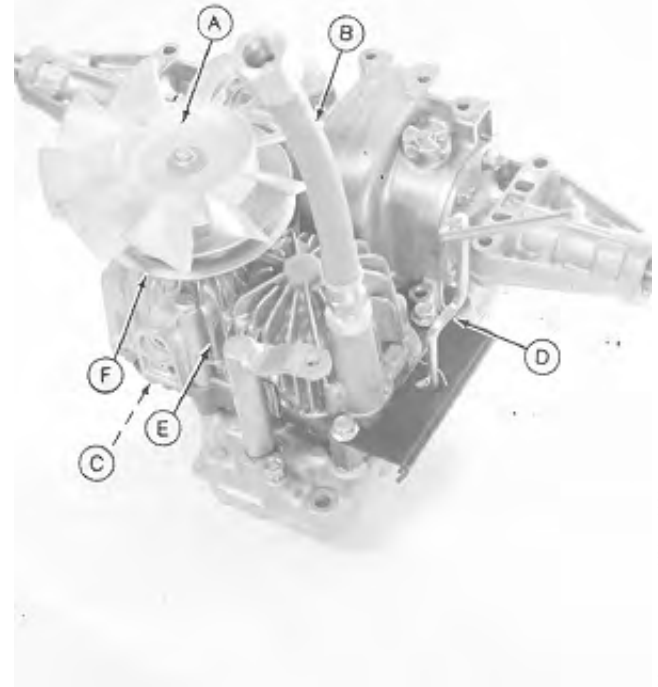

M21,5021S,A9 -19-23MAY88

-UN-08JAN90

M48169  
 50-21-5

## BLEED HYDROSTATIC SYSTEM

*NOTE: This service procedure is for the following machines: 185 (S.N. 475001— ).*

After installing a repaired or replacement part, follow this run-in procedure to assure that air is purged from the system.

1. Fill case and reservoir to FULL line. Transmission oil capacity is approximately 850 cc (28.7 fl oz).
2. Lift rear wheels off ground using hoist. Put jackstands under frame. Start engine and idle it for two or three minutes.
3. Apply full forward for 10 seconds.
4. Bring to NEUTRAL for five seconds.
5. Push tow (bleed) valve for two seconds.
6. Apply full forward for 15 seconds.
7. Stop engine. Fill reservoir to FULL line.
8. Start engine and idle it. Put transmission in NEUTRAL for 10 seconds.
9. Apply full forward for 10 seconds and return to NEUTRAL.
10. Stop engine. Fill reservoir to FULL line.
11. If necessary, repeat Steps 1—10.

M21,5021S,A10 -19-13MAY88

50  
21  
6



## OTHER MATERIAL

Number	Name	Use
	SAE 90 Oil	Assemble Differential

M21,5025S,ZA -19-22JAN86

## REMOVE HYDROSTATIC DIFFERENTIAL—PEERLESS

*NOTE: This service procedure is for the following machines: All 165, 175 and 185 (S.N. —475000).*

1. Remove hydrostatic differential and transmission assembly from tractor. (See Group 20 in this section.)
2. Remove transmission from differential. (See Group 20 in this section.)



M21,5025S,A1 -19-13MAY88

## DISASSEMBLE DIFFERENTIAL—PEERLESS

1. Remove brake assembly.



M21,5025S,A2 -19-18APR88

## Hydrostatic Differential—Peerless/Hydrostatic Differential

2. Remove cap screws and cover. Remove case gasket.



M21,5025S,C -19-22JAN86

M50339  
-UN-22DEC89

3. Remove brake shaft and thrust washer (A).

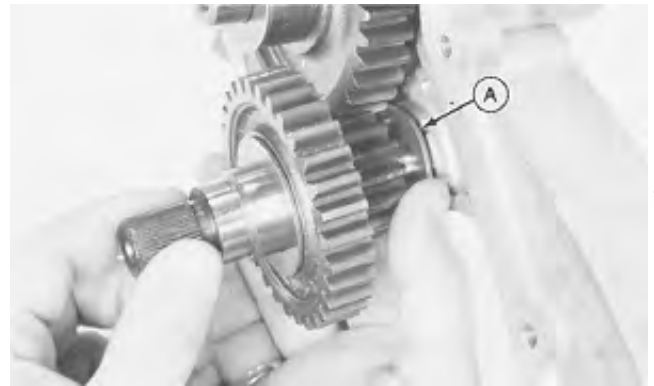

M21,5025S,D -19-22JAN86

M50340  
-UN-22DEC89

4. Remove thrust washer (A) and gear (B) from brake shaft (C).

5. Inspect surfaces of thrust washers (A) and brake shaft (C) for wear. Inspect gear teeth and splines for wear or damage. Replace parts if necessary.

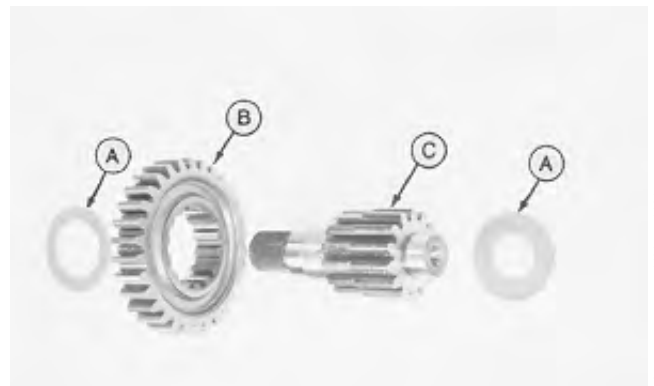

M21,5025S,E -19-22JAN86

M50381  
-UN-03JAN90

6. Remove output shaft.



M21,5025S,F -19-22JAN86

M50382  
-UN-03JAN90

50  
25  
2

7. Remove thrust washer (A) and spacer.

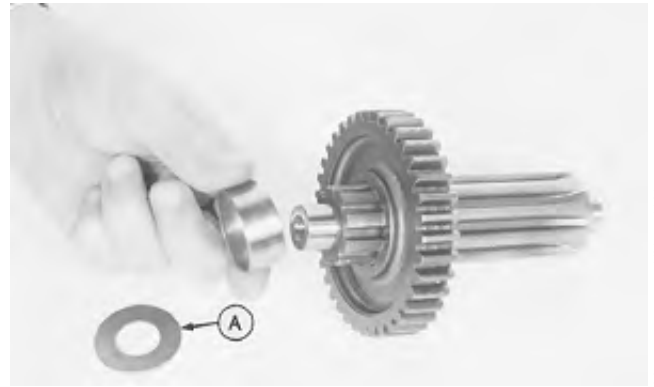

M21,5025S,G -19-22JAN86

M50383 -UN-03JAN90

8. Remove output gear using a plastic hammer.



M21,5025S,H -19-22JAN86

M50384 -UN-03JAN90

9. Inspect surfaces of thrust washer (A) and output shaft for wear. Inspect gear teeth and splines for wear or damage. Replace parts if necessary.

- A—Thrust Washer
- B—Spacer
- C—Output Gear
- D—Output Shaft

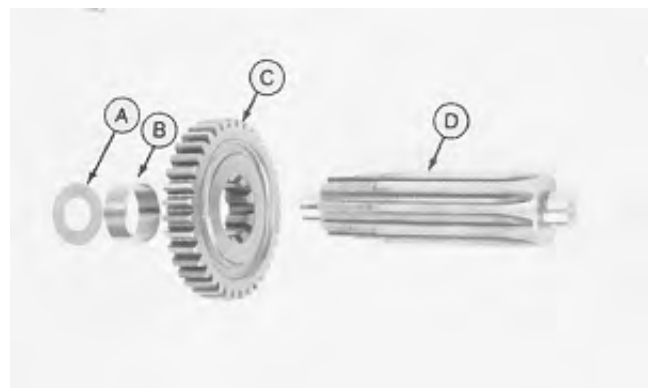

M21,5025S,I -19-22JAN86

M50385 -UN-03JAN90

10. Remove differential and axle assembly.



M21,5025S,J -19-22JAN86

M50387 -UN-03JAN90

## DISASSEMBLE DIFFERENTIAL AND AXLE

1. Remove cap screws and separate axles from ring gear.



M21,5025S,K -19-22JAN86

M50388  
-UN-03JAN90

2. Remove pinion blocks (A), pinion gears (B), and shaft (C) from ring gear (D).

- A—Pinion Blocks
- B—Pinion Gears
- C—Shaft
- D—Ring Gear

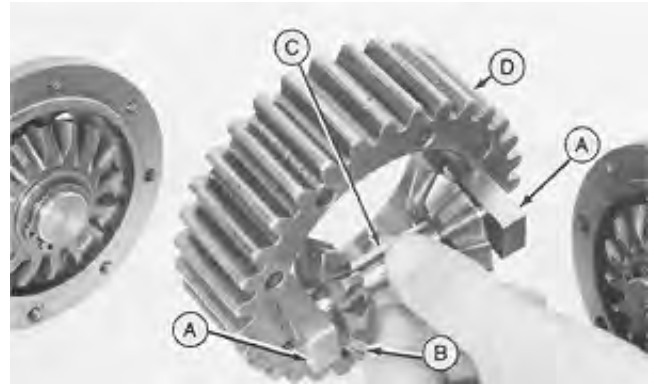

M21,5025S,L -19-22JAN86

M50389  
-UN-03JAN90

3. Remove snap ring.



M21,5025S,M -19-22JAN86

M50390  
-UN-03JAN90

4. Remove bevel gear (A), thrust washer (B), differential carrier (C), and two thrust washers (D) from each axle.

5. Inspect thrust washers (B and D), differential carrier (C), and axle (E) for wear. Inspect bevel gear (A) for wear or damage. Replace parts if necessary.

- A—Bevel Gear
- B—Thrust Washer
- C—Differential Carrier
- D—Thrust Washers
- E—Axle

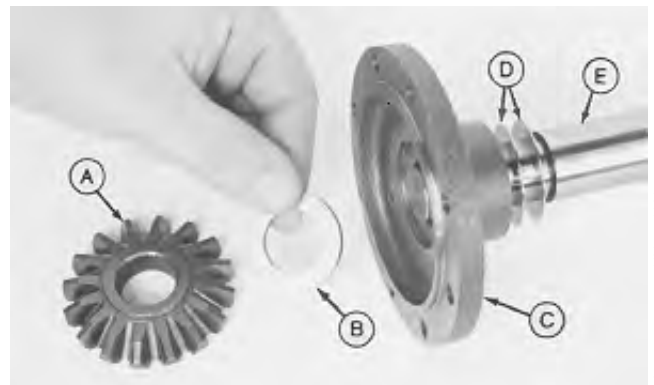

M21,5025S,N -19-22JAN86

M50391  
-UN-03JAN90

## INSPECT DIFFERENTIAL CASE

1. Inspect case and cover for cracks, stripped threads and marred sealing surfaces. Replace if necessary.
2. Inspect needle bearings (A) and seals (B and D) for wear. If seals or bearings are removed, press them out from inside of case and replace with new parts.
3. Inspect bushings (C) for wear. Replace parts if necessary.
4. Inspect differential carrier-to-case thrust surface for wear. If case thrust surface is worn more than 1.02 mm (0.040 in.), replace case.

A—Needle Bearings (4 used)  
 B—Brake Shaft Seal  
 C—Axle Bushings (4 used)  
 D—Axle Seals (2 used)

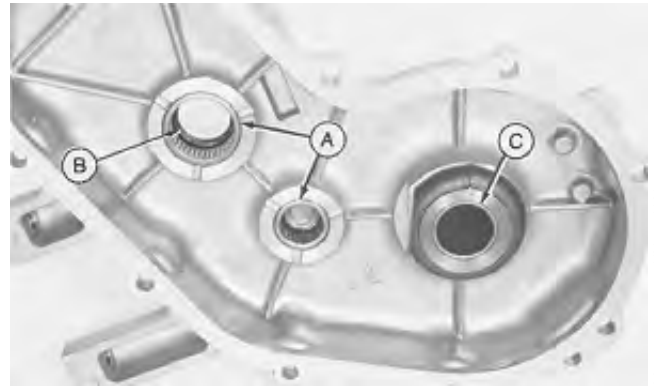

M50392  
 -UN-03JAN90

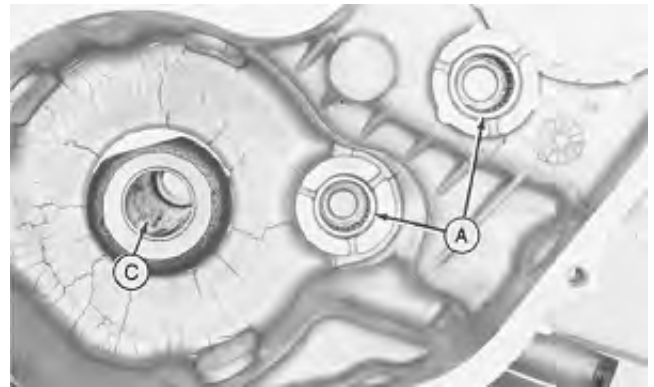

M50393  
 -UN-03JAN90

Cover and Case

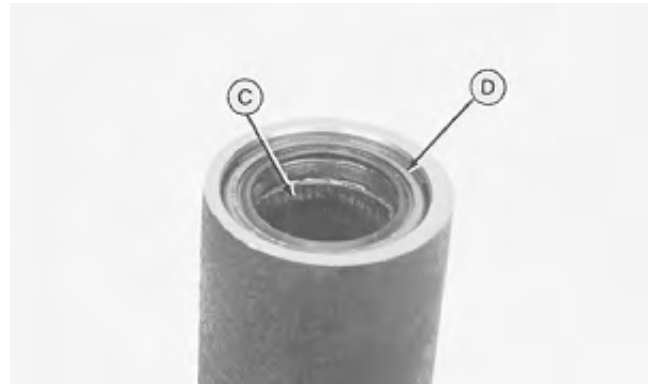

M50394  
 -UN-03JAN90

Axle Housing

M21,5025S,A3 -19-18APR88

## ASSEMBLE DIFFERENTIAL AND AXLE—PEERLESS

*NOTE: Lubricate all parts with SAE 90 oil during assembly.*

1. Install washers (D), carrier (C), washer (B) and gear (A) on both axles (E). Install snap ring.

A—Bevel Gear                      D—Thrust Washers  
 B—Thrust Washer                E—Axle  
 C—Differential Carrier

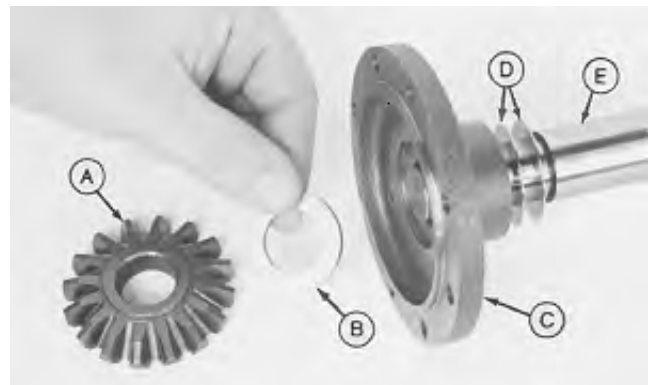

M50391  
 -UN-03JAN90

M21,5025S,A4 -19-18APR88

2. Install pinion gears (B) and pinion blocks (A) on shaft (C). Install pinion assembly into ring gear (D).

- A—Pinion Block
- B—Pinion Gear
- C—Shaft
- D—Ring Gear

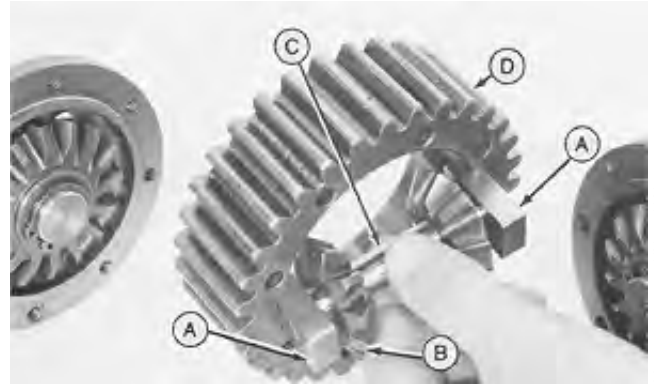

M21,5025S,Q -19-22JAN86

M50389 -UN-03JAN90

3. Install assembled ring gear between axles. Install and tighten cap screws to 9.5 N·m (84 lb-in.).



M21,5025S,R -19-22JAN86

M50395 -UN-03JAN90

## ASSEMBLE DIFFERENTIAL

**IMPORTANT:** When installing differential and axle assembly, be careful not to damage seal in axle housing.

1. Install differential and axle assembly.



M21,5025S,S -19-27MAR86

M50387 -UN-03JAN90

50  
25  
6

*NOTE: Install gear on shaft with chamfered side of internal spline towards the shaft.*

2. Install output gear (C) on ground shaft (D) using a plastic hammer.

3. Install spacer (B) and thrust washer (A) on output shaft.

- A—Thrust Washer
- B—Spacer
- C—Output Gear
- D—Output Shaft



M50386 -UN-03JAN90

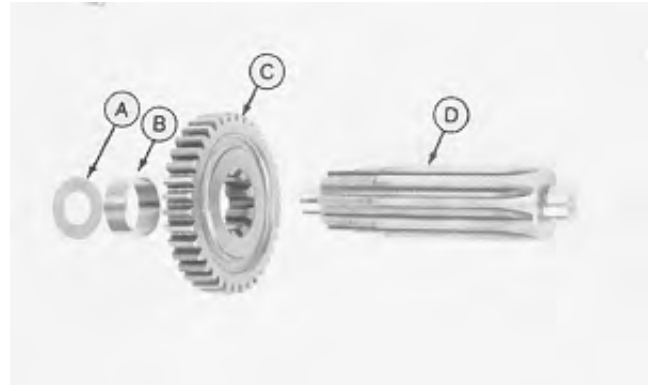

M50385 -UN-03JAN90

M21,5025S,T -19-27MAR86

4. Install output shaft assembly.



M50382 -UN-03JAN90

M21,5025S,U -19-22JAN86

5. Assemble brake shaft. Install brake shaft assembly by putting rear thrust washer (A) into position first.

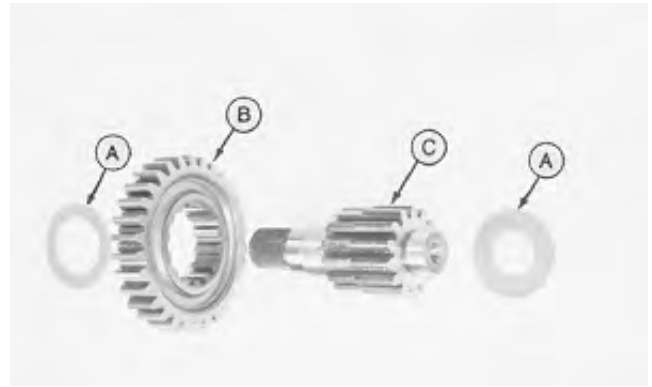

M50381 -UN-03JAN90

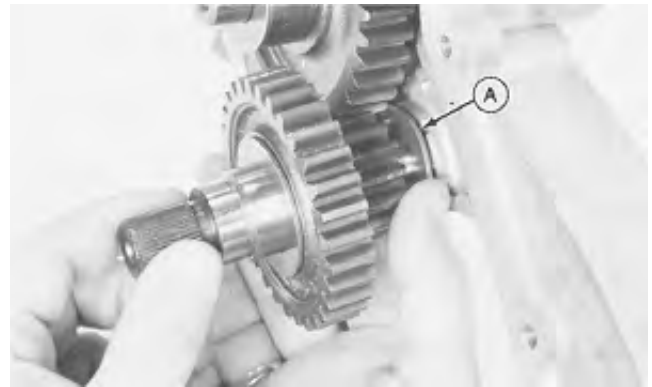

M50340 -UN-22DEC89

M21,5025S,V -19-22JAN86

**IMPORTANT:** When installing cover, be careful not to damage seal in axle housing.

*NOTE:* New differential cases have untapped bolt holes. Use the self-tapping cap screws when assembling.

6. Install new gasket and cover. Tighten cap screws to 11 N·m (97 lb-in.).

7. Install brake assembly.



M50339 -UN-22DEC89

M21,5025S,A5 -19-13MAY88

## INSTALL HYDROSTATIC DIFFERENTIAL—PEERLESS

1. Install transmission on hydrostatic differential. (See Group 20 in this section.)



M50247 -UN-22DEC89

M21,5025S,A6 -19-18APR88



*Hydrostatic Differential—Peerless/Hydrostatic Differential*

2. Remove fill plug. Add 0.7 L (1.5 pt) of SAE 90 oil to differential. Check for leaks.

3. Install differential and transmission assembly on tractor. (See Install Differential and Hydrostatic Transmission Assembly in Section 50, Group 20.)

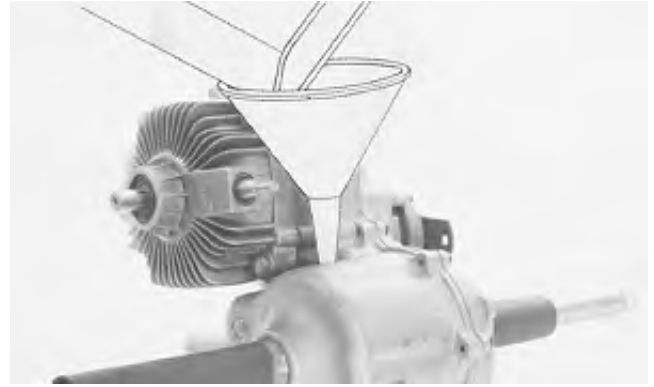

M21,5025S,Y -19-22JAN86

50  
25  
9

50  
25  
10

### OTHER MATERIAL

Number	Name	Use
	SAE 10W30 Oil	Fill Hydrostatic System

M21,5026S,A1 -19-18APR88

### SEPARATE DIFFERENTIAL AND TRANSMISSION

*NOTE: This service procedure is for the following machines: 185 (S.N. 475001— ).*

1. Clean transaxle assembly and drain oil.
2. Remove items (A—F).

A—Fan  
B—Hose  
C—Drain Plug  
D—Tow Linkage  
E—Transmission  
F—Sheave

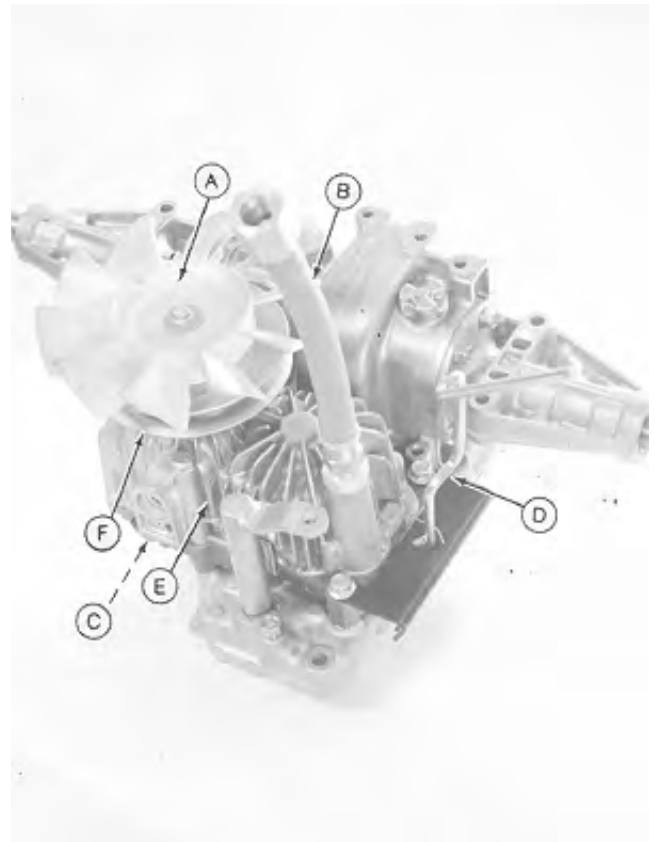

M21,5026S,A2 -19-23MAY88

50  
26  
1

M48169  
-UN-08JAN90

## DISASSEMBLE TRANSMISSION—KANZAKI

NOTE: This service procedure is for the following machines: 185 (S.N. 475001— ).

1. Remove cover and idler gear assembly (B—E).
2. Measure idler gear (E) and idler shaft (B).

### WEAR TOLERANCE SPECIFICATIONS

Idler Gear I.D. ....	21.01—21.03 mm (0.827—0.828 in.)
Idler Shaft O.D. ....	16.99—17.00 mm (0.668—0.669 in.)

- A—Differential Case Assembly
- B—Idler Shaft
- C—Washer (2 used)
- D—Needle Bearings
- E—Idler Gear
- F—Cover
- G—Tapping Bolt (13 used)
- H—Drain Plug

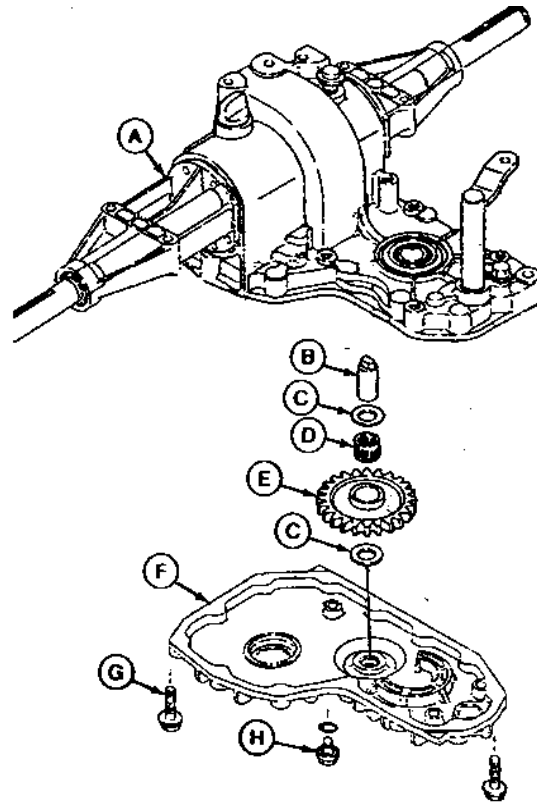

M21,5026S,A3 -19-13MAY88

-UN-31/AUG88  
M46108

3. Remove motor gear assembly (B—D) and brake assembly (E—O).

4. Measure brake components.

### WEAR TOLERANCE SPECIFICATIONS

Cam Lever Shaft O.D. (E) ....	19.97—20.03 mm (0.786—0.788 in.)
Cam Lever Shaft Bore I.D. (Cover) ....	20.10—20.20 mm (0.791—0.795 in.)
Bore I.D. (Housing) ....	20.05—20.08 mm (0.789—0.790 in.)
Actuator (L) (includes ball) ....	9.10—9.30 mm (0.358—0.366 in.)
Disc (M) ....	1.90—2.10 mm (0.075—0.083 in.)
Plate (N) ....	2.40—2.60 mm (0.094—0.102 in.)

- A—Transaxle Case Assembly
- B—Spacer
- C—Bearing
- D—Motor Gear
- E—Cam Lever Shaft
- F—Tapping Bolt
- G—Plate
- H—Packing (2 used)
- I—Spring
- J—Pin
- K—Ball (3 used)
- L—Actuator
- M—Disc
- N—Plate
- O—Collar

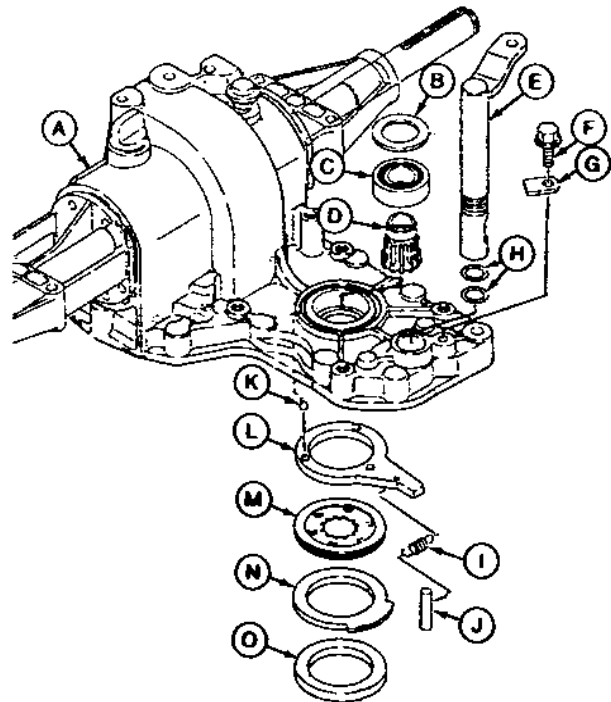

M21,5026S,A4 -19-13MAY88

-UN-31/AUG88  
M46109

5. Remove left and right axle assemblies (A—Q).

6. Measure axle housings (E—P).

**WEAR TOLERANCE SPECIFICATIONS**

Axle Housing O.D. (Needle Bearing) . . . . . 24.98—25.00 mm  
(0.983—0.984 in.)

- A—Left Axle Shaft
- B—Seal (2 used)
- C—Snap Ring (2 used)
- D—Needle Bearing (2 used)
- E—Left Axle Housing
- F—Tapping Bolt (12 used)
- G—Packing
- H—Washer (4 used)
- I—Bearing
- J—Snap Ring (2 used)
- K—Shim Pack
- L—Bearing
- M—Transaxle Case
- N—Bearing
- O—Packing
- P—Right Axle Housing
- Q—Right Axle Shaft

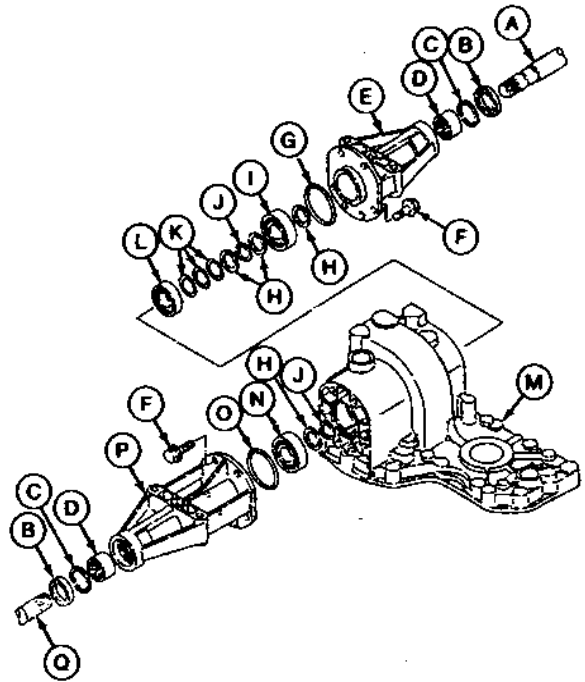

M21,5026S,A5 -19-18APR88

M46110 -UN-31AUG88

50  
26

7. Remove pinion drive assembly (B—L).

8. Measure counter gear (K) and pinion drive (B).

**WEAR TOLERANCE SPECIFICATIONS**

Counter Gear I.D. . . . . 20.01—20.03 mm  
(0.788—0.789 in.)

Pinion Drive O.D. . . . . 20.00—20.02 mm  
(0.78—0.79 in.)

- A—Transaxle Case
- B—Pinion drive
- C—Key
- D—Pin (2 used)
- E—Bearing Retainer
- F—Tapping Bolt (6 used)
- G—Bearing
- H—Snap Ring
- I—Washer
- J—Snap Ring
- K—Counter Gear
- L—Bearing

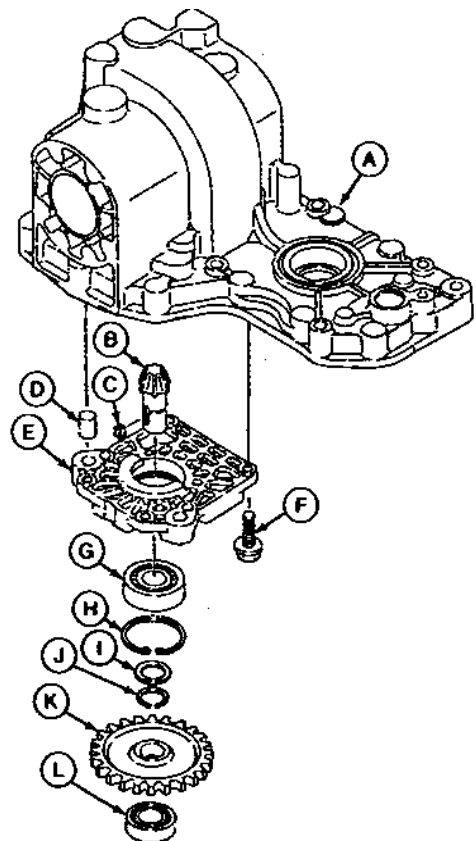

M21,5026S,A6 -19-13MAY88

M46111 -UN-31AUG88

M46111

9. Remove differential assembly (B—I).

10. Measure pinion shaft (F), pinion gear (G) and differential case (H).

**WEAR TOLERANCE SPECIFICATIONS**

Pinion Shaft O.D. . . . . .	13.97—13.98 mm (0.549—0.550 in.)
Pinion Gear I.D. . . . . .	14.03—14.05 mm (0.552—0.553 in.)
Differential Case I.D. (Axle) . . . . .	20.08—20.10 mm (0.79—0.791 in.)

- A—Transaxle case
- B—Bearing
- C—Cap Screw (8 used)
- D—Differential Case
- E—Gear
- F—Pinion Shaft
- G—Pinion Gear
- H—Differential Case
- I—Ring Gear

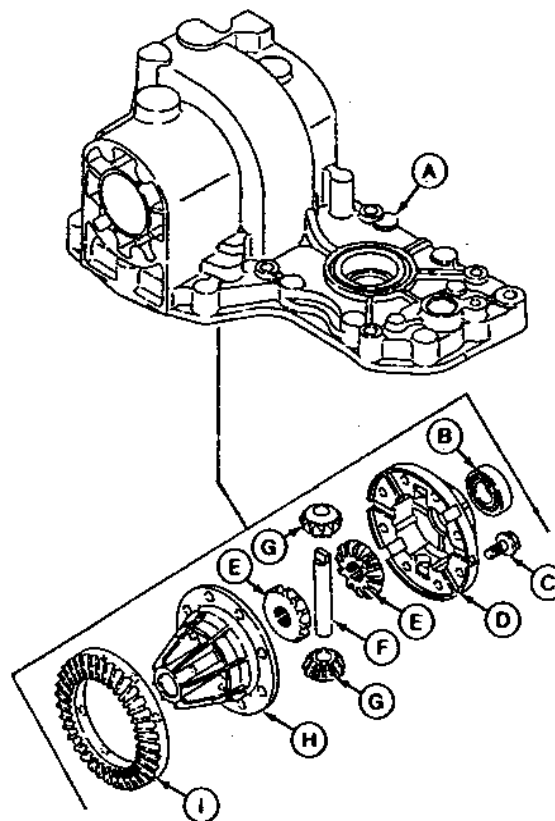

M46112 -UN-31/AUG88

M21,5026S,A7 -19-18APR88

50  
26  
4

**ASSEMBLE DIFFERENTIAL—KANZAKI**

*NOTE: This service procedure is for the following machines: 185 (S.N. 475001— ).*

1. Clean screw threads using clean and cure primer. Apply thread lock and sealer (medium strength) on cap screw threads.

2. Assemble differential assembly (B—I).

3. Tighten cap screws (C) to 26 N·m (230 lb-in.).

- A—Transaxle Case
- B—Bearing
- C—Cap Screw (8 used)
- D—Differential Case
- E—Gear
- F—Pinion Shaft
- G—Pinion Gear
- H—Differential Case
- I—Ring Gear

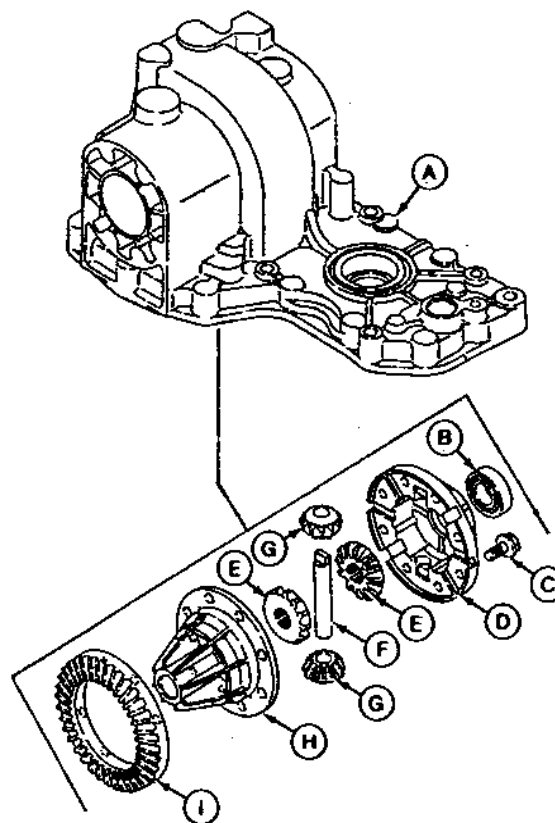

M46112 -UN-31/AUG88

M21,5026S,AB -19-13MAY88

**NOTE:** Ring gear to pinion drive gear backlash must be checked after pinion drive assembly and axles are installed. See step 8. Install items (C, K and L) after checking backlash.

4. Assemble pinion drive assembly (except items C, K and L).

**NOTE:** New differential cases have untapped bolt holes. Use the higher torque when installing tapping bolts.

5. Tighten tapping bolts (F) to:

New Case . . . . . 29 N-m (260 lb-in.)  
Used Case . . . . . 25 N-m (221 lb-in.)

- A—Transaxle case
- B—Pinion Gear
- C—Key
- D—Pin (2 used)
- E—Bearing Retainer
- F—Tapping Bolts (6 used)
- G—Bearing
- H—Snap Ring
- I—Washer
- J—Snap Ring
- K—Counter Gear
- L—Bearing

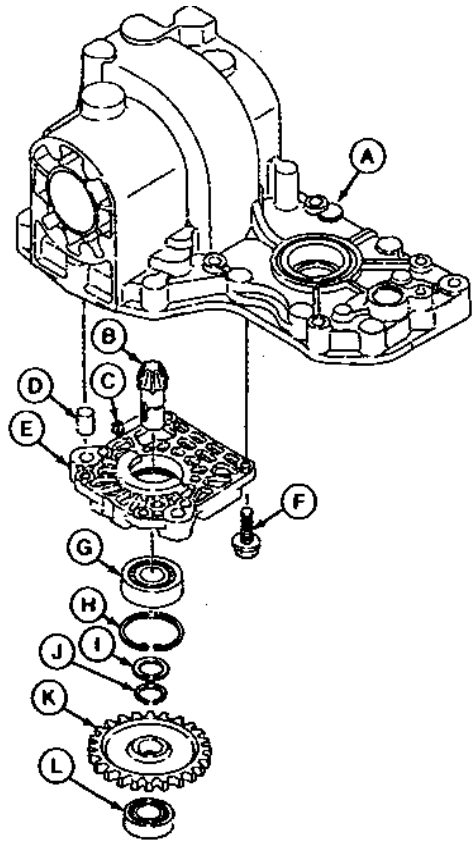

M21,5026S,A9 -19-18APR88

-UN-31AUG88

M46111  
50-26-5

**NOTE:** Install the same number and thickness of shims (K) that were removed.

6. Assemble and install left and right axle assemblies (A—Q).

**NOTE:** new differential cases have untapped bolt holes. Use the higher torque when installing tapping bolts.

7. Tighten tapping bolts (F) to:

New Case . . . . . 29 N-m (22 lb-ft)  
Used Case . . . . . 25 N-m (221 lb-in.)

- |                           |                      |
|---------------------------|----------------------|
| A—Left Axle Shaft         | I—Bearing            |
| B—Seal (2 used)           | J—Snap Ring (2 used) |
| C—Snap Ring (2 used)      | K—Shim Pack          |
| D—Needle Bearing (2 used) | L—Bearing            |
| E—Left Axle Housing       | M—Transaxle Case     |
| F—Tapping Bolt (12 used)  | N—Bearing            |
| G—Packing                 | O—Packing            |
| H—Washer (4 used)         | P—Right Axle Housing |
|                           | Q—Right Axle Shaft   |

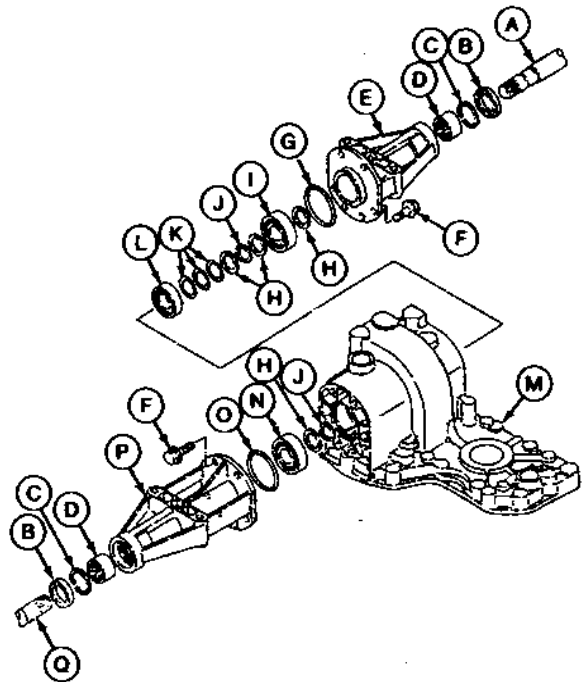

M21,5026S,A10 -19-13MAY88

-UN-31AUG88

M46110

**NOTE:** When checking backlash, hold axles and differential assembly solid.

8. Measure ring gear to pinion drive gear backlash at key groove (A). Backlash specification is 0.15—0.30 mm (0.006—0.012 in.).

9. Adjust backlash by adding or subtracting left axle shaft shims.

**NOTE:** install counter gear and bearing, see Step 4.



M21,5026S,A11 -19-18APR88

M46113 -UN-08JAN90

10. Install brake assembly (E—O) and motor gear assembly (B—D).

**NOTE:** New differential cases have untapped bolt holes. Use the higher torque when installing tapping bolts.

11. Tighten tapping bolts (F) to:

New Case	.....	29 N·m (22 lb-ft)
Used Case	.....	25 N·m (221 lb-in.)

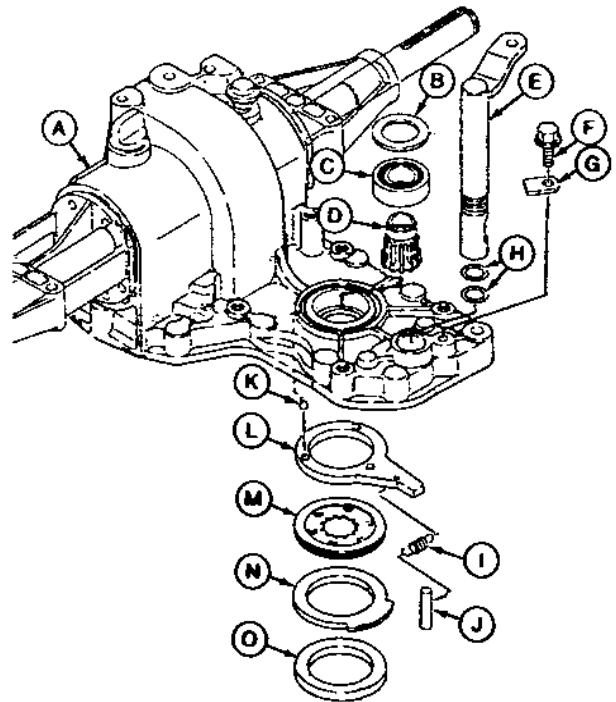

- A—Transaxle Case Assembly
- B—Spacer
- C—Bearing
- D—Motor Gear
- E—Cam Lever Shaft
- F—Tapping Bolt
- G—Plate
- H—Packing (2 used)
- I—Spring
- J—Pin
- K—Ball (3 used)
- L—Actuator
- M—Disc
- N—Plate
- O—Collar

M21,5026S,A12 -19-13MAY88

M46109 -UN-31/AUG88

50  
26  
6



12. Assemble idler gear assembly (B—E). Oil grooves in idler gear (E) go toward cover (F).

13. Apply flexible sealant or an equivalent on gasket surface of the differential cover and case.

*NOTE: New differential cases have untapped bolt holes. Use the higher torque when installing tapping bolts.*

14. Install cover and tapping bolts (G). Tighten tapping bolts to:

New Case . . . . . 29 N·m (22 lb-ft)  
Used Case . . . . . 25 N·m (221 lb-in.)

- A—Transaxle Case Assembly
- B—Idler Shaft
- C—Washer (2 used)
- D—Needle Bearing
- E—Idler Gear
- F—Cover
- G—Tapping Bolt (13 used)
- H—Drain Plug

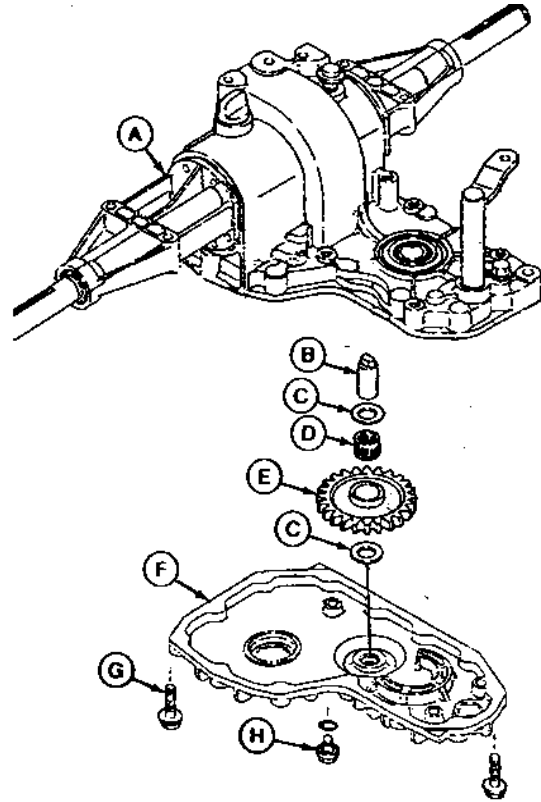

M21,5026S,A13 -19-13MAY88

M48108 -UN-31/AUG88

50  
26  
7

## ASSEMBLE DIFFERENTIAL AND TRANSMISSION

1. Install items (A—F).

2. Tighten drain plug (C) to 15 N·m (130 lb-in.).

3. After installing the complete transaxle into the machine, bleed the hydrostatic system. (See Group 21 in this section.)

- A—Fan
- B—Hose
- C—Drain Plug
- D—Tow Linkage
- E—Transmission
- F—Sheave

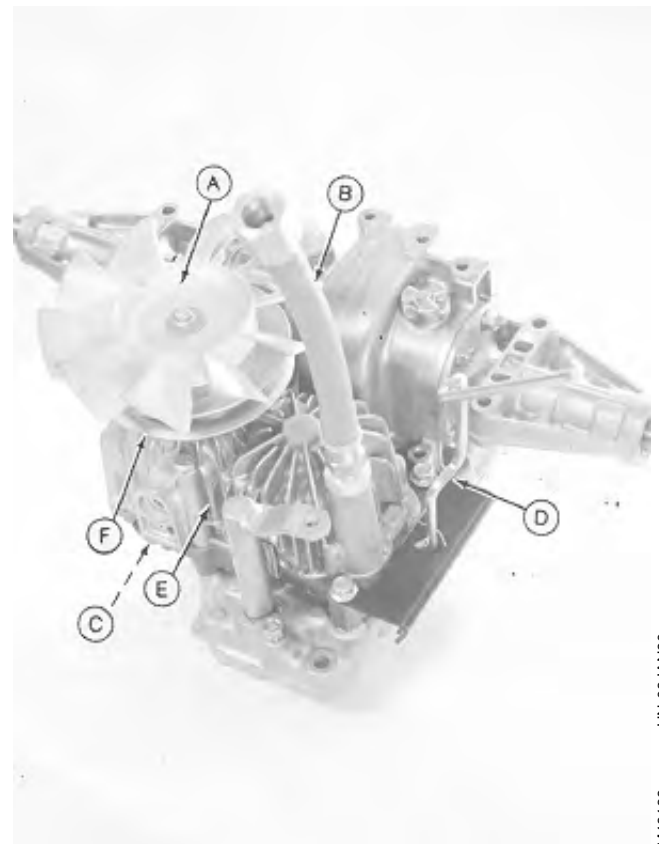

M21,5021S,A9 -19-23MAY88

M48169 -UN-08/JAN90

50  
26  
8

# Section 60 Steering and Brakes

## Contents

### Page

#### Group 05—Steering System

Remove Steering Wheel and Shaft . . . . .	60-05-1
Remove Steering Gear Support . . . . .	60-05-3
Disassemble and Clean Sector Gear Support . . . . .	60-05-4
Inspect and Repair Steering System . . . . .	60-05-5
Assemble Sector Gear Support . . . . .	60-05-6
Install Steering Gear Support . . . . .	60-05-6
Install Steering Wheel and Shaft . . . . .	60-05-7
Adjust Steering . . . . .	60-05-8

#### Group 10—Front Axle

Other Materials . . . . .	60-10-1
Front Axle Remove . . . . .	60-10-1
Inspect and Repair . . . . .	60-10-3
Install . . . . .	60-10-4

#### Group 15—Brakes and Linkages

Other Material . . . . .	60-15-1
Brake Assembly—130, 160 and 180 Remove . . . . .	60-15-1
Inspect and Repair . . . . .	60-15-2
Install . . . . .	60-15-3
Brake Assembly—All 165, 175 and 185 (S.N.—475000) Remove . . . . .	60-15-3
Inspect and Repair . . . . .	60-15-5
Install . . . . .	60-15-6
Adjust Brakes . . . . .	60-15-7

#### Contents



## REMOVE STEERING WHEEL AND SHAFT

1. Remove lock nut and washer.



M21.6005S,A -19-03JAN86

M50279 -UN-22DEC89

2. Drive out pin and remove steering wheel.



M21.6005S,B -19-03JAN86

M50280 -UN-22DEC89

3. Remove pedestal shroud.
4. Disconnect all wires and indicator lights from dash.



M21.6005S,C -19-03JAN86

M50281 -UN-22DEC89

5. Loosen two nuts (A) and remove two nuts (B).



M21.6005S,D -19-03JAN86

M50282 -UN-22DEC89

Steering System/Remove Steering Wheel and Shaft

**IMPORTANT: Do not bend throttle lever, when lifting dash. It remains fastened to pedestal.**

6. Lift dash. Remove cotter pin and bearing (A).

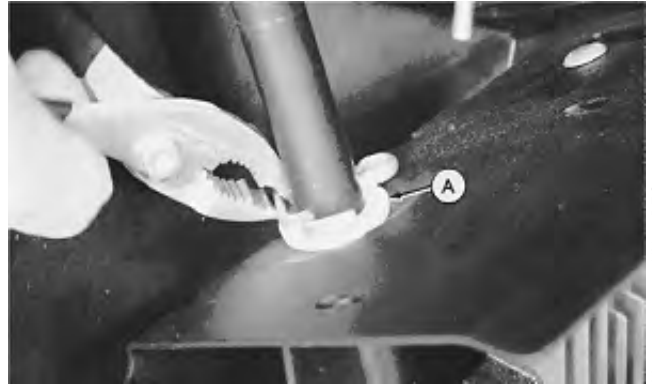

M21.6005S,E -19-03JAN86

M50283 -UN-22DEC89

7. Remove cotter pin (A).



M21.6005S,F -19-03JAN86

M50284 -UN-22DEC89

8. Drive shaft up through pinion gear and remove gear and washer.



M21.6005S,G -19-03JAN86

M50285 -UN-22DEC89

9. Remove bearing by aligning sector gear teeth with outside diameter of bearing.



M21.6005S,H -19-03JAN86

M50286 -UN-22DEC89

## Steering System/Remove Steering Gear Support

10. Lift shaft and remove washers and spring.
11. Remove cotter pin (A) and remove shaft.



M21,6005S,I -19-03JAN86

M50287 -UN-22DEC89

### REMOVE STEERING GEAR SUPPORT

1. Disconnect drag link.



M21,6005S,J -19-27MAR86

M50167 -UN-22DEC89

2. Remove two nuts from support.



M21,6005S,K -19-03JAN86

M50288 -UN-22DEC89

3. Remove sector gear support.



M21,6005S,L -19-03JAN86

M50289 -UN-22DEC89

## DISASSEMBLE AND CLEAN SECTOR GEAR SUPPORT

**⚠ CAUTION:** Be careful when removing cotter pin. Spring is compressed.

1. Remove cotter pin, washers, spring, and support.



M21,6005S,M -19-27MAR86

M50290 -UN-22DEC89

2. Mark sector gear and sector shaft for alignment for ease of assembly.

3. Remove bearing, washer and sector gear.

4. Remove cotter pin to remove steering sector support (B) and bearing (A).

5. Remove grease and clean parts in solvent. Dry parts.



M21,6005S,N -19-03JAN86

M50291 -UN-22DEC89



## INSPECT AND REPAIR STEERING SYSTEM

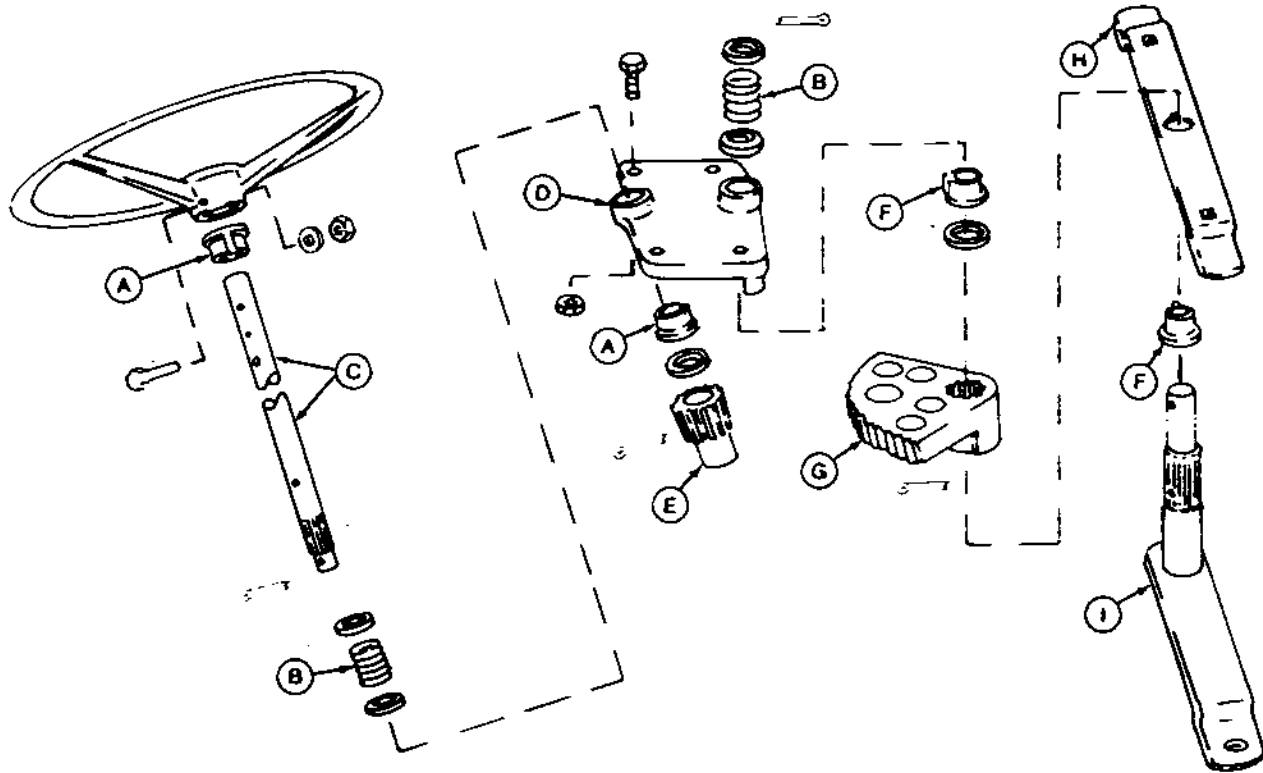

A—Steering Shaft Bearings  
B—Springs  
C—Steering Shaft

D—Support  
E—Pinion Gear

F—Sector Shaft Bearings  
G—Sector Gear

H—Steering Sector Support  
I—Sector Shaft

1. Inspect steering shaft bushings (A) for wear or cracks.

2. Inspect springs (B) for damage.

3. Inspect steering shaft (C) and sector shaft (I) for wear or bent conditions. Inspect splines for wear.

4. Inspect pinion gear (E) and sector gear (G) for worn, broken or damaged teeth and wear on inside diameters.

5. Inspect support (D) for cracks.

6. Inspect sector shaft bearings (F) for wear or cracks.

M50292 -UN-26APR89

60  
5105

M21,6005S,O -19-27MAR86

## ASSEMBLE SECTOR GEAR SUPPORT

1. Install bearing (A) and sector gear support (B) on sector shaft.
2. Install cotter pin, sector gear, washer, and bearing on sector shaft. Make sure mark on gear aligns with mark on shaft.



M21.6005S,P -19-03JAN86

M50291 -UN-22DEC89

3. Install sector gear support, washers, spring and cotter pin on sector shaft.



M21.6005S,Q -19-03JAN86

M50290 -UN-22DEC89

## INSTALL STEERING GEAR SUPPORT

1. Install steering gear support.



M21.6005S,R -19-03JAN86

M50289 -UN-22DEC89

2. Install and tighten two nuts.
3. Connect drag link.



M21.6005S,S -19-03JAN86

M50288 -UN-22DEC89

## INSTALL STEERING WHEEL AND SHAFT

1. Install shaft in pedestal.
2. Install cotter pin (A), washers and spring on steering shaft.



M21,6005S,T -19-03JAN86

M50287  
-UN-22DEC89

3. Install bushing (A) and cotter pin.



M21,6005S,U -19-03JAN86

M50283  
-UN-22DEC89

4. Install steering wheel. Drive pin through wheel and shaft. Install and tighten washer and nut.



M21,6005S,V -19-03JAN86

M50293  
-UN-22DEC89

5. Install steering shaft bushing.



M21,6005S,W -19-03JAN86

M50286  
-UN-22DEC89

## Steering System/Adjust Steering

6. Put logo on steering wheel in horizontal position and pull down on steering wheel. Install washer and pinion gear, making sure dot (A) on pinion gear is in alignment with dot (B) on sector gear.

7. Install cotter pin.

8. Connect drag link.



M21.6005S,X -19-03JAN86

M50294  
-UN-22DEC89

9. Put dash in position and install nuts (B). Tighten nuts (A and B).

10. Connect all dash wires and indicator lights.

11. Install pedestal shroud.

12. Adjust steering. (See Adjust Steering in this group.)



M21.6005S,Y -19-03JAN86

M50282  
-UN-22DEC89

## ADJUST STEERING

1. Make sure dots on pinion gear and sector gear are aligned. If wheels are straight forward no further adjustment is required, otherwise continue with following steps.

2. Disconnect drag link from spindle.

3. With dots still aligned, put wheels straight forward.

4. Loosen nut and turn ball joint until drag link fits easily into spindle without moving wheels.

5. Tighten nut against ball joint. Connect drag link to spindle.



M21.6005S,Z -19-03JAN86

M50295  
-UN-22DEC89

## OTHER MATERIAL

Number	Name	Use
	John Deere MultiPurpose Grease	Lubricate axles and spindles

M21.6010S,X -19-27JAN86

## REMOVE FRONT AXLE

1. Remove cap screw, spacer, washer, and nut on both sides, and remove hood.
2. Remove muffler. (See Replace Muffler in Section 20, Group 20.)



M21.6010S,H -19-27MAR85

3. Remove two cap screws and remove muffler guard.



M21.6010S,I -19-11DEC85

4. Remove electric PTO clutch. (See Remove Electric PTO Clutch in Section 40, Group 05.)
5. Remove two cap screws from rear pivot anchor.



M21.6010S,J -19-11DEC85

Front Axle/Front Axle

6. Turn pivot anchors (A) onto pivot shaft and remove axle.

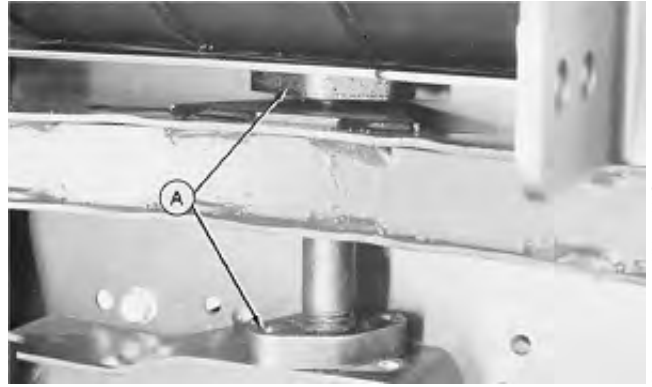

M50171 -UN-31AUG88

M21,6010S,K -19-11DEC85

60  
10  
2

## INSPECT AND REPAIR FRONT WHEEL AND AXLE ASSEMBLIES

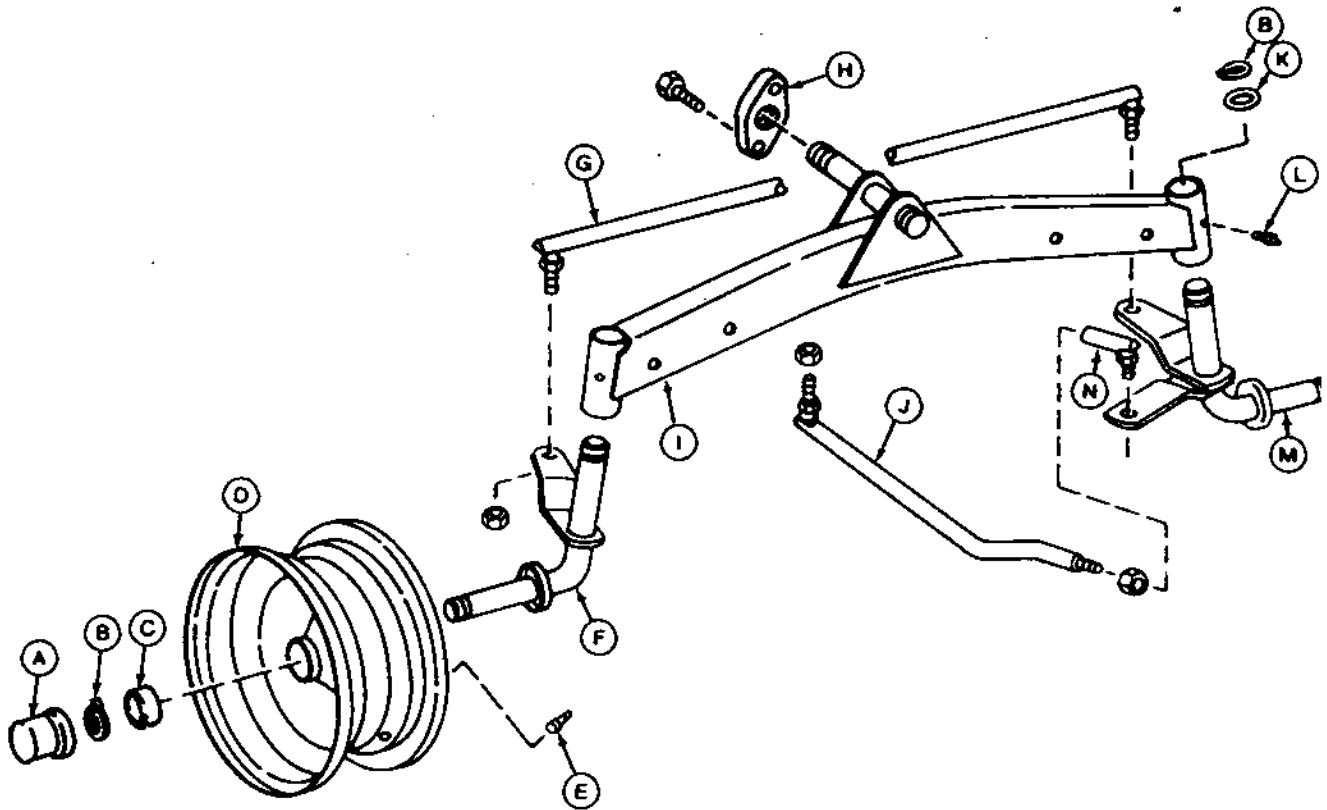

A—Cap (2 used)  
 B—Snap Ring (4 used)  
 C—Ball Bearing (4 used)  
 D—Front Wheel (2 used)  
 E—Air Valve (2 used)  
 F—Right Spindle  
 G—Tie Rod  
 H—Pivot Pin Anchor (2 used)

I—Axle  
 J—Drag Link  
 K—Spindle Washer (2 used)

L—Grease Fitting (2 used)  
 M—Left Spindle  
 N—Ball Joint

1. Inspect wheel bearings for wear. If wheel wobbles when rotated or bearings are visually worn, replace bearings.

- a. Remove bearings from wheel by driving them out with a punch.
- b. Put multi-purpose grease on new bearings.
- c. Drive new bearings into wheel hub with driver.

2. Inspect tie rod and drag link for bent condition. Inspect ball joints for wear and free movement. Replace any worn or bent parts.

3. Put spindle in axle and check spindle bore for wear or being out-of-round. Replace worn parts.

4. Apply multi-purpose grease on spindles before installing in axle.

5. Grease wheel bearings and pack cavity between bearings with multi-purpose grease and put a small amount on axle.

M50313 -UN-26APR89

60  
10  
3

## INSTALL FRONT AXLE

1. Install axle under tractor. Match boss on pivot anchors with holes in frame.
2. Turn pivot anchors against frame and align cap screw holes.

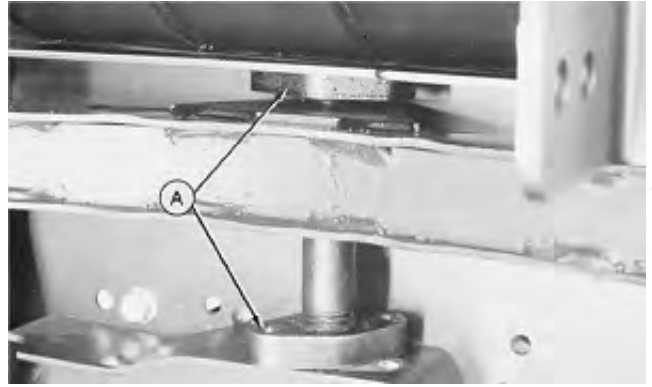

M21,6010S,M -19-27MAR85

M50171 -UN-31AUG88

3. Install and tighten two cap screws.



M21,6010S,N -19-11DEC85

M50170 -UN-22DEC89

4. Install muffler guard with two cap screws.
5. Install muffler. (See Replace Muffler in Section 20, Group 20.)



M21,6010S,O -19-27MAR85

M50169 -UN-22DEC89

6. Install hood with two cap screws, spacers, washers and nuts.
7. If necessary, adjust steering. (See Group 05 in this section.)



M21,6010S,A2 -19-18APR88

M50168 -UN-22DEC89



**OTHER MATERIAL**

Number	Name	Use
	LUBRIPLATE®	Lubricate brake pins

LUBRIPLATE is a trademark of Fiske Brothers Refining.

M21,6015S,N -19-25JAN86

**REMOVE BRAKE ASSEMBLY—MODELS 130, 160, AND 180**

1. Put blocks under tractor frame and remove right rear wheel.
2. Disconnect brake linkage.



M50270 -UN-22DEC89

M21,6015S,A -19-31DEC85

*NOTE: Brake assembly consists of loose parts. Do not lose parts when removing assembly.*

3. Remove two cap screws and remove brake assembly.



M50271 -UN-22DEC89

M21,6015S,B -19-31DEC85

4. Slide disk off shaft. Remove pad from behind disk.



M50272 -UN-22DEC89

M21,6015S,C -19-31DEC85

**INSPECT AND REPAIR BRAKE ASSEMBLY—MODELS 130, 160 AND 180**

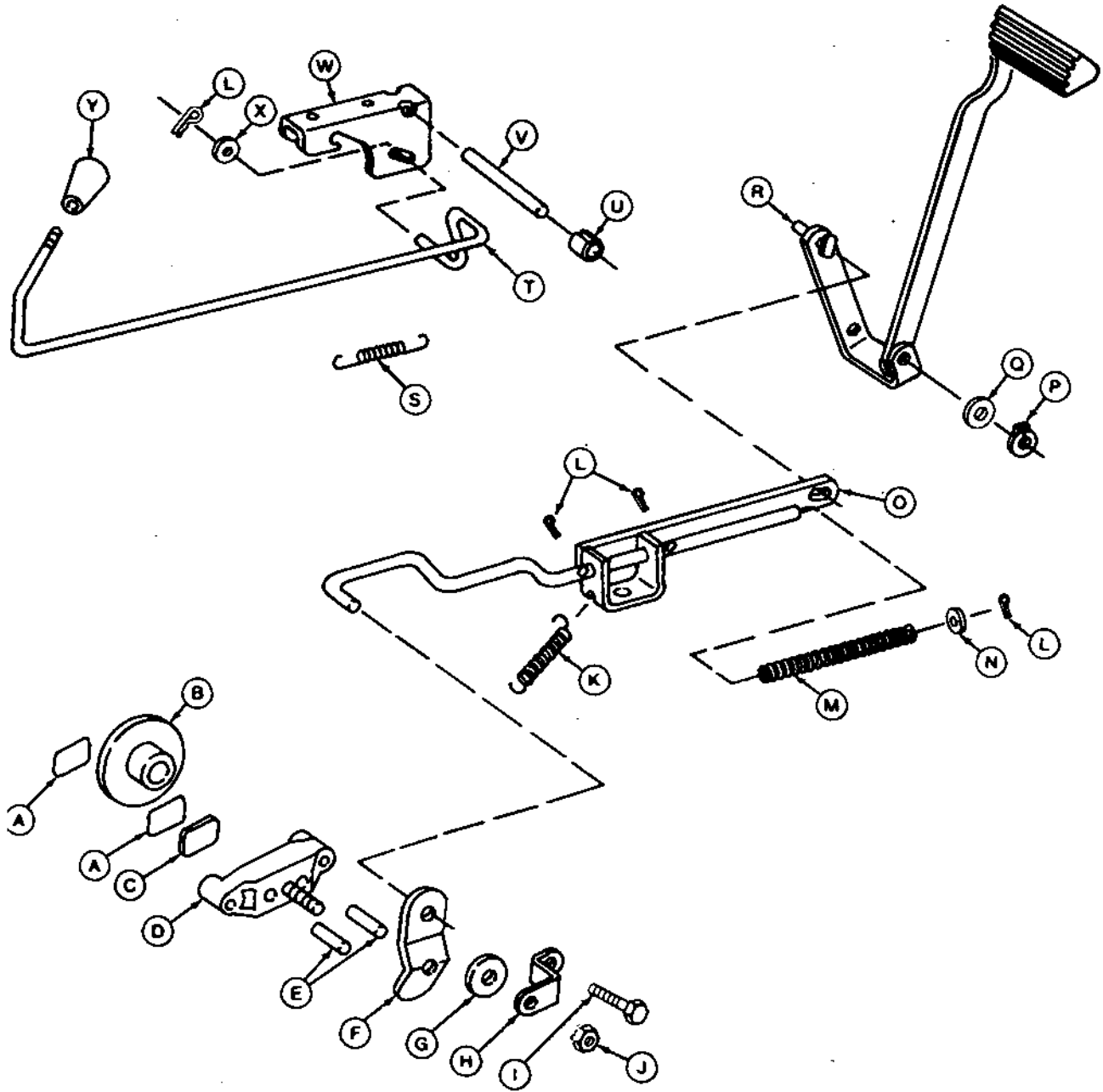

A—Brake Pad (2 used)  
 B—Disk  
 C—Plate  
 D—Holder  
 E—Dowel Pin (2 used)  
 F—Lever  
 G—Washer

H—Bracket  
 I—Cap Screw (2 used)  
 J—Nut  
 K—Spring  
 L—Cotter Pin  
 M—Spring

N—Washer  
 O—Strap  
 P—Snap Ring  
 Q—Washer  
 R—Pedal  
 S—Spring

T—Park Brake Rod  
 U—Spacer  
 V—Pivot Pin  
 W—Park Brake Latch  
 X—Washer  
 Y—Park Brake Knob

1. Inspect pads and plate for wear or damage.
2. Inspect disk for wear or cracks.
3. Replace parts as necessary.

M21,6015S,L -19-28JAN86

## INSTALL BRAKE ASSEMBLY—MODELS 130, 160, AND 180

**IMPORTANT:** Brake pads and disk must be free of grease and oil.

1. Put LUBRIPLATE on brake shaft.
2. Install pad and disk with hub out.



M21,6015S,D -19-31DEC85

M50272  
-UN-22DEC89

3. Install brake assembly. Install and tighten two cap screws.
4. Connect brake linkage.
5. Install right rear wheel.
6. Adjust brakes. (See Adjust Brakes in this group.)



M21,6015S,E -19-31DEC85

M50271  
-UN-22DEC89

## REMOVE BRAKE ASSEMBLY—ALL 165, 175 AND 185 (S.N. —475000)

*NOTE:* For 185 (S.N. 475001— ), see Section 50, Group 26.

*NOTE:* To remove brake disk, transmission must be lowered. brake pads can be removed without lowering transmission.

1. Put blocks under tractor frame and remove left rear wheels.
2. Disconnect brake linkage.



M21,6015S,A1 -19-16MAY88

M50275  
-UN-22DEC89

60  
15  
3

*NOTE: Brake assembly consists of loose parts. Do not lose parts.*

3. Remove two cap screws and remove brake assembly.

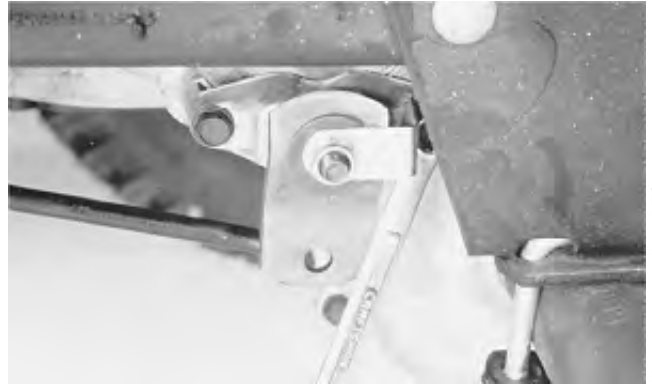

M50276  
-UN-22DEC89

M21,6015S,G -19-31DEC85

4. Slide disk against frame and remove rear pad.



M50277  
-UN-22DEC89

M21,6015S,H -19-31DEC85

**INSPECT AND REPAIR BRAKE ASSEMBLY—ALL 165, 175 AND 185 (S.N. —475000)**

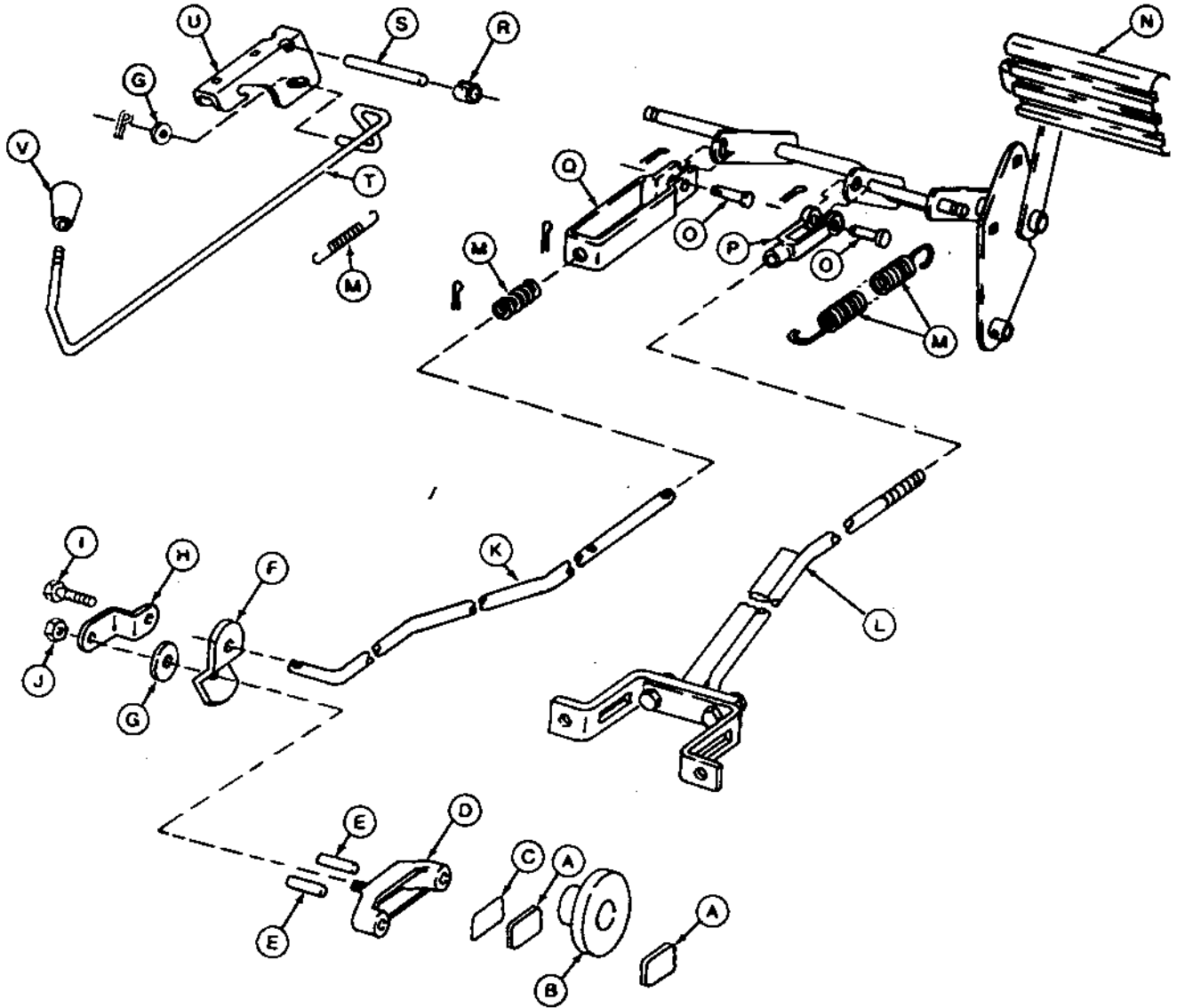

- |                      |                      |            |                    |
|----------------------|----------------------|------------|--------------------|
| A—Brake Pad (2 used) | G—Washer             | M—Spring   | R—Bushing          |
| B—Disk               | H—Bracket            | N—Pedal    | S—Pivot Pin        |
| C—Plate              | I—Cap Screw (2 used) | O—Pin      | T—Park Brake Rod   |
| D—Holder             | J—Nut                | P—Yoke     | U—Park Brake Latch |
| E—Dowel Pin (2 used) | K—Rod                | Q—Retainer | V—Park Brake Knob  |
| F—Lever              | L—Linkage            |            |                    |

NOTE: For 185 (S.N. 475001— ), see Section 50, Group 26.

1. Inspect pads and plate for wear or damage.
2. Inspect disk for wear or cracks.
3. Replace parts as necessary.

M21,6015S,A2 -19-16MAY88

## INSTALL BRAKE ASSEMBLY—ALL 165, 175 AND 185 (S.N. —475000)

*NOTE:* For 185 (S.N. 475001— ), see Section 50, Group 26.

**IMPORTANT:** Brake pads and disk must be free of grease and oil.

1. Put Lubriplate on brake shaft.
2. Install pad and slide disk towards differential.



M50277 -UN-22DEC89

M21.6015S,A3 -19-16MAY88

3. Install brake assembly. Install and tighten two cap screws.
4. Connect brake linkage.
5. Install left rear wheel.
6. Adjust brakes. (See Adjust Brakes in this group.)



M50276 -UN-22DEC89

M21.6015S,J -19-31DEC85

61516

**ADJUST BRAKES—ALL 165, 175 AND 185  
(S.N. —475000)**

*NOTE: For 185 (S.N. 475001— ), see Section 250-10.*

1. Make sure park brake is disengaged.
2. With a feeler gauge, inspect clearance between pad and disk. Clearance should be 0.50 mm (0.020 in.).
3. Turn nut to obtain proper clearance.



*Gear Driven Tractor*



*Hydrostatic Driven Tractor*

M21,6015S,A4 -19-16MAY88

M50273 -UN-22DEC89

M50274 -UN-22DEC89

# Contents

8



# Section 80 MISCELLANEOUS

## Contents

Page

### Group 05—Mower Spindles

Other Materials . . . . .	80-05-1
Mower Spindle	
Remove . . . . .	80-05-1
Service 30-Inch . . . . .	80-05-3
Service 38-Inch (S.N.—420000) . . . . .	80-05-4
Disassemble 38-Inch (S.N. 420001—) . . . . .	80-05-5
Assemble 38-Inch (S.N. 420001—) . . . . .	80-05-6
Service 46-Inch . . . . .	80-05-7
Install . . . . .	80-05-8

### Group 10—Mower Lift Linkage

Lift Lever Assembly	
Remove . . . . .	80-10-1
Disassemble . . . . .	80-10-2
Assemble . . . . .	80-10-3
Install . . . . .	80-10-4



## OTHER MATERIAL

Number	Name	Use
	SAE MultiPurpose Grease	Lubricate spindles

M21,7005S,K -19-27JAN86

## REMOVE MOWER SPINDLE

*NOTE: Mower spindles normally require no lubrication or service. If the spindle must be disassembled, be sure to lubricate and torque parts as instructed.*

1. Remove mower from tractor.
2. On 38 and 46-inch mowers, remove mower drive belt.



M50424 -UN-03JAN90

M21,7005S,A -19-27MAR86

3. Remove nut, mower drive sheave and key. On 30-inch mower, remove two spacers.



M50431 -UN-03JAN90

30-Inch Mower Shown

M21,7005S,B -19-24JAN86

**CAUTION:** Wear gloves or wrap blade with a cloth when you remove the blade.

4. Remove cap screw and washer to remove blade.



M50432 -UN-03JAN90

M21,7005S,C -19-24JAN86

Mower Spindles/Mower Spindle

5. Remove nuts and bolts.
6. Remove spindle assembly.



M21,7005S,D -19-24JAN86

M50433 -UN-03JAN90

2318

## SERVICE 30-INCH MOWER SPINDLE

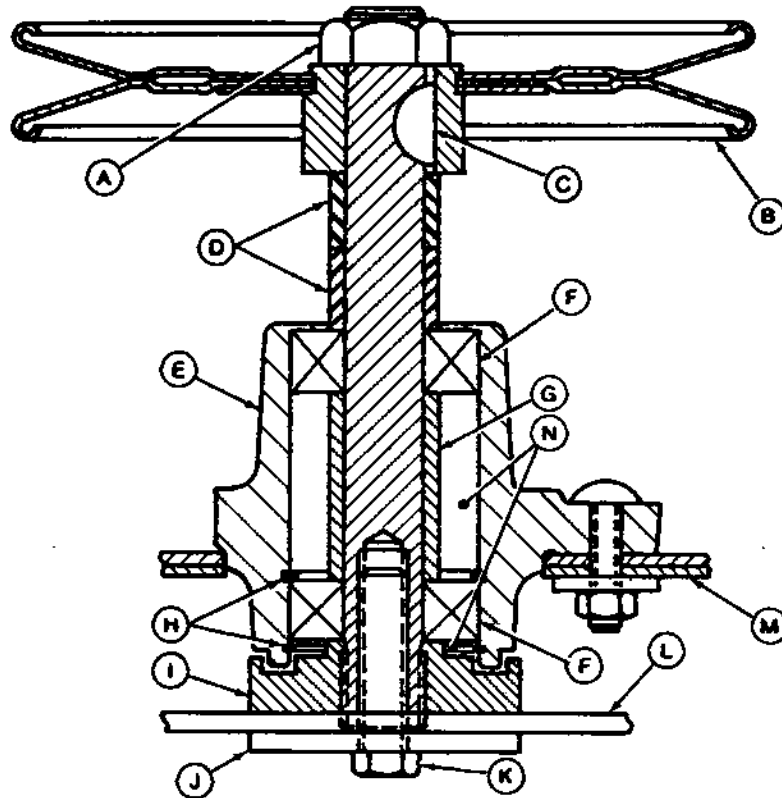

A—Nut  
B—Sheave  
C—Key  
D—Spacer (2 used)

E—Hub  
F—Ball Bearing (2 used)  
G—Spacer  
H—Snap Ring (2 used)

I—Spindle Shaft  
J—Washer  
K—Cap Screw

L—Blade  
M—Plate  
N—Grease Areas

1. Press spindle shaft (I) down through hub (E).
2. Remove lower snap ring (H). Press on inner and outer rings of upper bearing (F) and remove lower bearing (F) and spacer (G).
3. Turn hub over and press upper bearing (F) out.
4. Inspect bearings, shaft, spacer and hub for wear or damage. Replace parts if necessary.
5. Position lower bearing in hub. Make sure land riding seal of bearing is away from hub. Press bearing against upper snap ring.
6. Put spacer (G) into position. Fill area (N) around spacer 50 to 60 percent full of SAE multipurpose grease.
7. Support lower bearing and put upper bearing into position. Make sure land riding seal of bearing is away from hub. Press upper bearing against spacer (G), keeping spacer in position.
8. Install lower snap ring (H). Fill area (N) around snap ring 50 to 60 percent full of SAE multipurpose grease.
9. Support inner ring of upper bearing and press spindle shaft (I) into hub.
10. Check rolling torque of spindle. Maximum allowable torque is 0.07 N·m (0.6 lb-in.).

M50334 -UN-26APR89

80  
05  
3

**SERVICE 38-INCH MOWER SPINDLE (S.N. —420000)**

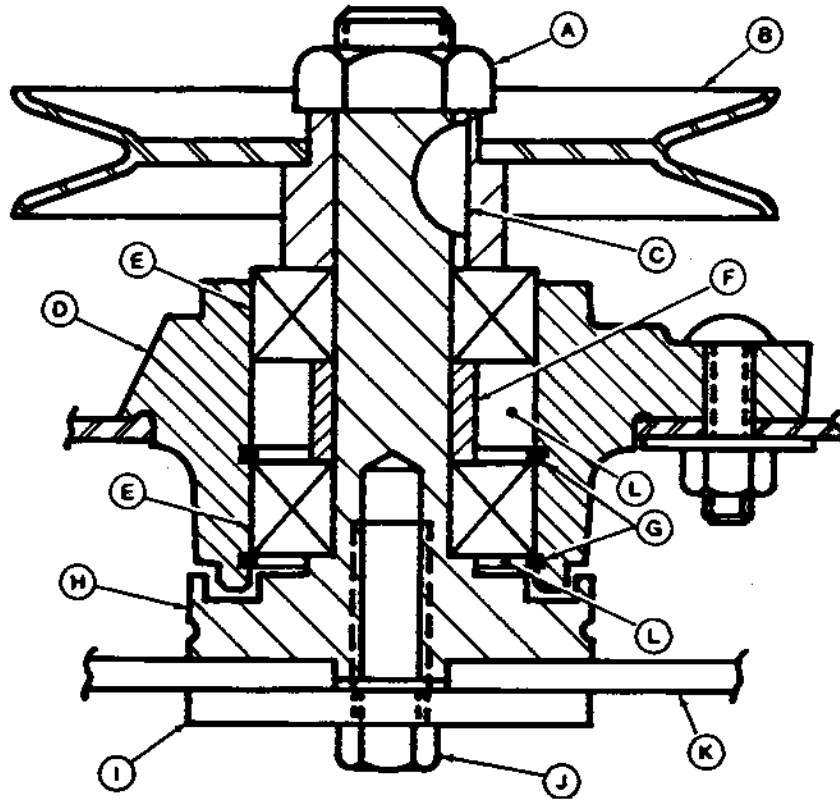

- |          |                         |                      |                |
|----------|-------------------------|----------------------|----------------|
| A—Nut    | D—Hub                   | G—Snap Ring (2 used) | J—Cap Screw    |
| B—Sheave | E—Ball Bearing (2 used) | H—Spindle Shaft      | K—Blade        |
| C—Key    | F—Spacer                | I—Washer             | L—Grease Areas |

*NOTE: There are two spindles on the 38-inch mower.*

1. Press spindle shaft (H) down through hub (D).
2. Remove lower snap ring (G). Press on inner and outer rings of upper bearing (E) and remove lower bearing (E) and spacer (F).
3. Turn hub over and press upper bearing (E) out.
4. Inspect bearings, shaft, spacer and hub for wear or damage. Replace parts if necessary.
5. Position lower bearing in hub. Make sure land riding seal of bearing is away from hub. Press bearing against upper snap ring.
6. Put spacer (F) into position. Fill area (L) around spacer 50—60 percent full of SAE multipurpose Grease.
7. Support lower bearing and put upper bearing into position. Make sure land riding seal of bearing is away from hub. Press upper bearing against spacer (F), keeping spacer in position.
8. Install lower snap ring (G). Fill area (L) around snap ring 50—60 percent full of SAE multipurpose grease.
9. Support inner ring of upper bearing and press spindle shaft (H) into hub.
10. Check rolling torque of spindle. Maximum allowable torque is 0.07 N·m (0.60 lb-in.).

M50335 -UN-26APR89

DISASSEMBLE SPINDLE—38-INCH MOWER (S.N. 420001— )

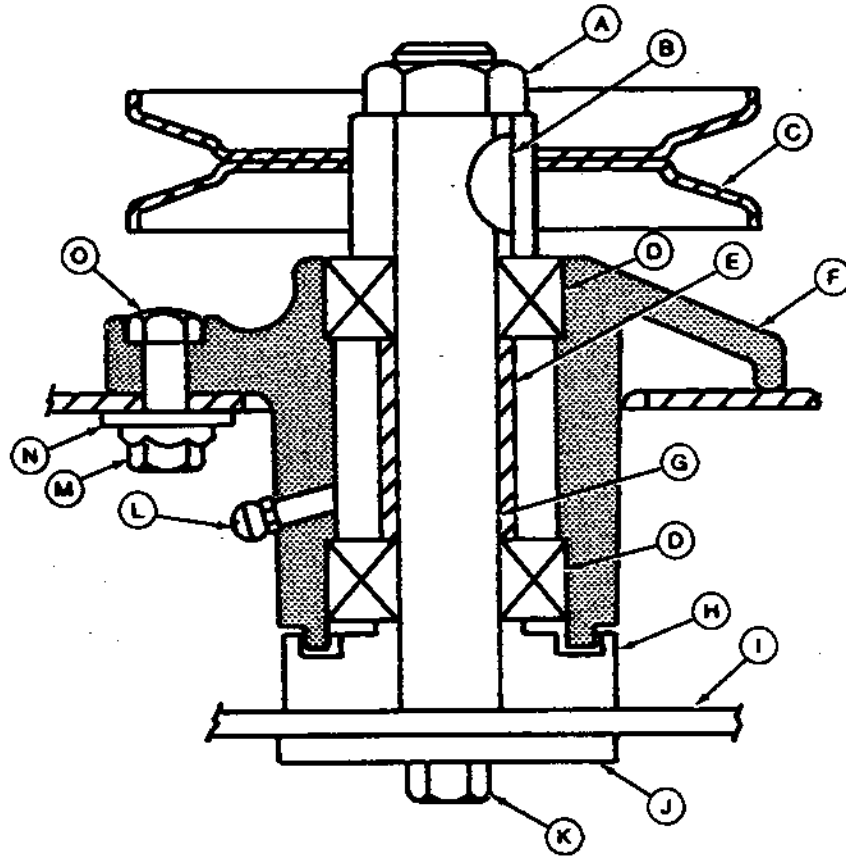

A—Lock Nut  
 B—Key  
 C—Sheave Assembly  
 D—Bearing (2 used)

E—Spacer  
 F—Housing  
 G—Shaft  
 H—Hub

I—Blade  
 J—Washer  
 K—Cap Screw  
 L—Grease Fitting

M—Nut (4 used)  
 N—Washer (4 used)  
 O—Cap Screw (4 used)

M46008 -UN-24APR89

80-05

## ASSEMBLE SPINDLE—38-INCH MOWER (S.N. 420001— )

1. Clean threads on shaft and hub using clean and cure primer. Apply thread lock and sealer (medium strength) on threads. Install hub on shaft.



M37339 -UN-08JUL91

M21,7005S,A6 -19-16MAY88

2. Install bearing (C) to bottom of bore in housing.
3. Install spacer (B).
4. Install bearing (A) to bottom of bore in housing.



M46009 -UN-08JAN90

M22,8005G,4 -19-05NOV86

5. Align internal spacer with shaft. Press in shaft until it bottoms.

**IMPORTANT: To prevent bearing damage, press only on inner race.**

6. Press housing onto shaft using a deep-well socket (A) or piece of pipe until shaft assembly bottoms on lower bearing.

7. Install key, sheave, and lock nut. Tighten lock nut to 140 N-m (103 lb-ft).

8. Fill spindle housing completely with John Deere multipurpose grease or equivalent.



M46010 -UN-08JAN90



M46011 -UN-08JAN90

M22,8005G,5 -19-05NOV86



**SERVICE 46-INCH MOWER SPINDLE**

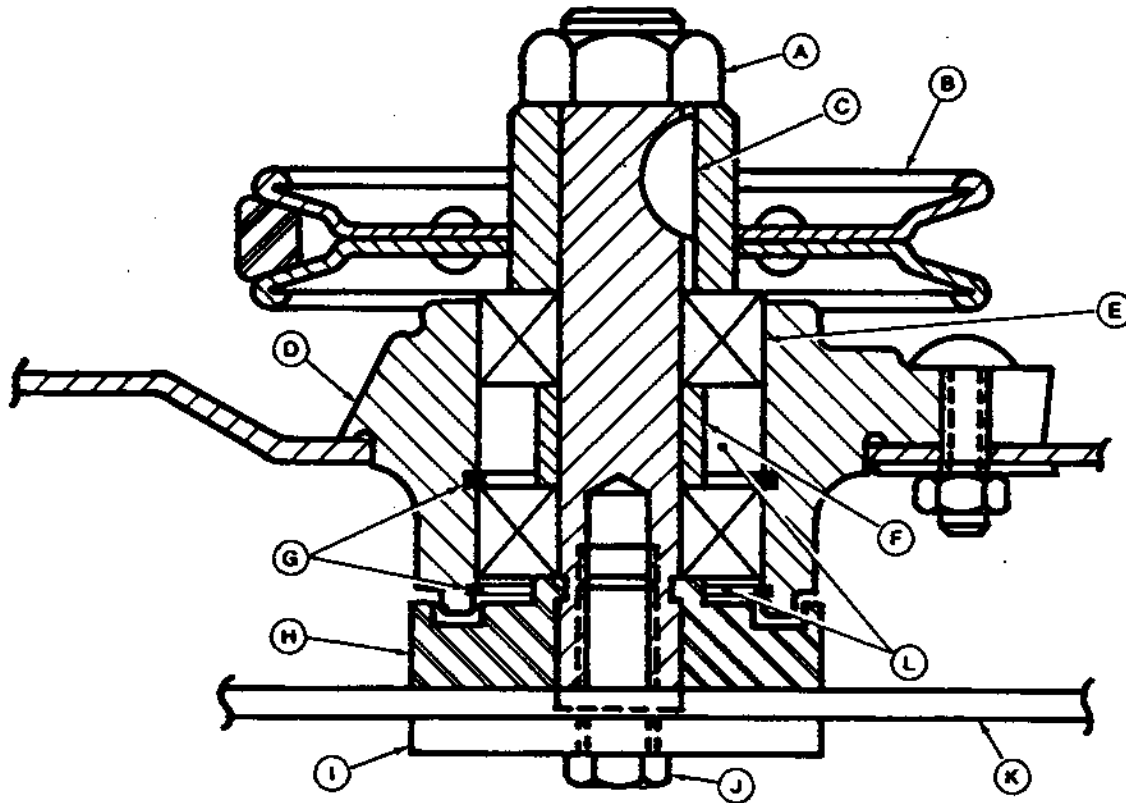

- |          |                         |                      |                |
|----------|-------------------------|----------------------|----------------|
| A—Nut    | D—Hub                   | G—Snap Ring (2 used) | J—Cap Screw    |
| B—Sheave | E—Ball Bearing (2 used) | H—Spindle Shaft      | K—Blade        |
| C—Key    | F—Spacer                | I—Washer             | L—Grease Areas |

*NOTE: There are three spindles on the 46-inch mower.*

1. Press spindle shaft (H) down through housing (D).
2. Remove lower snap ring (G). Press on inner and outer rings of upper bearing (E) and remove lower bearing (E) and spacer (F).
3. Turn hub over and press upper bearing (E) out.
4. Inspect bearings, shaft, spacer and hub for wear or damage. Replace parts if necessary.
5. Position lower bearing in hub. Make sure land riding seal of bearing is away from hub. Press bearing against upper snap ring.
6. Put spacer (F) into position. Fill area (L) around spacer 50 to 60 percent full of SAE multipurpose grease.
7. Support lower bearing and put upper bearing into position. Make sure land riding seal of bearing is away from hub. Press upper bearing against spacer (F), keeping spacer in position.
8. Install lower snap ring (G). Fill area (L) around snap ring 50 to 60 percent full of SAE multipurpose grease.
9. Support inner ring of upper bearing and press spindle shaft (H) into hub.
10. Check rolling torque of spindle. Maximum allowable torque is 0.07 N·m (0.6 lb-in.)

M50336 -UN-31AUG88

80  
05  
7

## INSTALL MOWER SPINDLE

1. Install spindle assembly in mower deck. Install and tighten nuts and bolts to 25 N·m (221 lb-in.).

30-inch Mower Shown



M50434  
-UN-03JAN90

M21,7005S,A1 -19-18APR88

**⚠ CAUTION: Wear gloves or wrap blade with a cloth when you install the blade.**

2. Install blade, washer and cap screw. Tighten cap screw to 75 N·m (55 lb-ft).

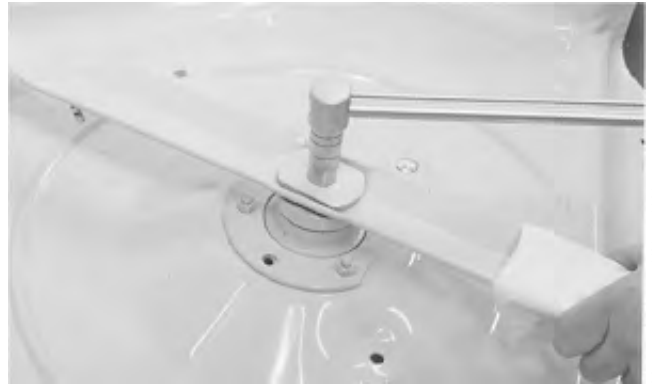

M50435  
-UN-03JAN90

M21,7005S,A2 -19-18APR88

3. On 30-inch mower, install two spacers. Install key, mower drive sheave and nut. Tighten nut to 125 N·m (92 lb-ft).

4. Install mower drive belt for 38 and 46-inch mowers.

5. Install mower on tractor.

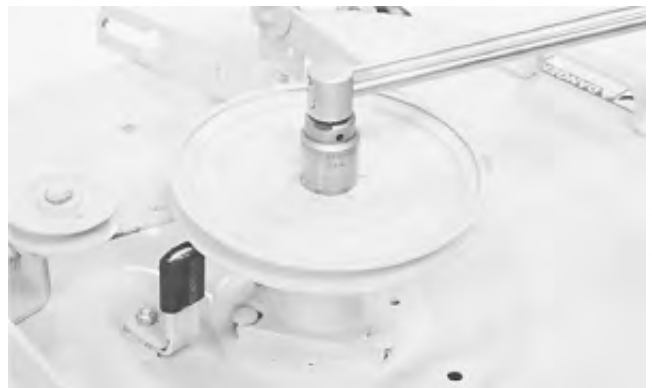

M50436  
-UN-03JAN90

M21,7005S,A3 -19-18APR88

## REMOVE LIFT LEVER ASSEMBLY

1. Remove mower.
2. Remove pedestal shroud, control knobs, and platform.
3. Relieve spring tension by rotating bracket (A) down.
4. Remove spring pin and washer.



M21,7010S,A -19-24DEC85

M50228  
-UN-22DEC89

5. Remove bracket and spring.



M21,7010S,B -19-24DEC85

M50229  
-UN-22DEC89

6. Remove snap rings from both ends of lift shaft.



M21,7010S,C -19-24DEC85

M50230  
-UN-22DEC89

7. Loosen all nuts on left plate.



M21,7010S,D -19-24DEC85

M50231  
-UN-22DEC89

## Mower Lift Linkage/Lift Lever Assembly

8. Remove front cap screw and nut from latch.



M21,7010S,E -19-24DEC85

M50232  
-UN-22DEC89

9. Raise lift lever. Remove rear nut to remove cap screw and lift latch.



M21,7010S,F -19-24DEC85

M50233  
-UN-22DEC89

10. Push lift shaft to right side of tractor and pull left plate away from frame. Remove lift lever assembly.



M21,7010S,G -19-24DEC85

M50234  
-UN-22DEC89

### DISASSEMBLE LIFT LEVER ASSEMBLY

1. Pull or cut grip off handle.



M21,7010S,H -19-24DEC85

M50235  
-UN-22DEC89

## Mower Lift Linkage/Lift Lever Assembly

2. Turn button counterclockwise to remove it.



M21,7010S,I -19-24DEC85

M50236  
-UN-22DEC89

3. Remove spring and washer.



M21,7010S,J -19-24DEC85

M50237  
-UN-22DEC89

4. Remove cap screw, spacer, and washer.

5. Pull latch hook (A) and rod (B) from lift handle.

6. Inspect parts. Replace damaged or worn parts.

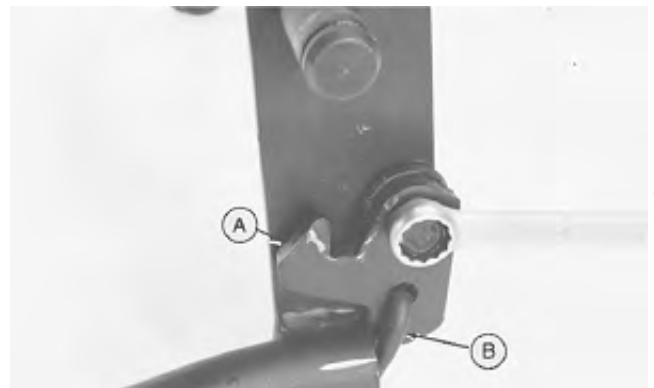

M21,7010S,K -19-24DEC85

M50238  
-UN-22DEC89

### ASSEMBLE LIFT LEVER ASSEMBLY

1. Install rod and latch hook in lift handle.

2. Install washer, spacer, and cap screw. Tighten cap screw.



M21,7010S,L -19-02FEB87

M50239  
-UN-22DEC89

## Mower Lift Linkage/Lift Lever Assembly

3. Install washer and spring.



M21,7010S,M -19-24DEC85

M50237  
-UN-22DEC89

4. Install and tighten push button.



M21,7010S,N -19-24DEC85

M50236  
-UN-22DEC89

5. Moisten inside of handle with water. Push grip on handle.



M21,7010S,O -19-24DEC85

M50235  
-UN-22DEC89

### INSTALL LIFT LEVER ASSEMBLY

1. Install lift shaft under wiring harness and fuel line. Push shaft to right and put in mounting holes.



M21,7010S,P -19-24DEC85

M50234  
-UN-22DEC89

## Mower Lift Linkage/Lift Lever Assembly

2. Raise lift lever and install latch and rear cap screw.  
Install nut on cap screw.



M21,7010S,Q -19-24DEC85

M50233  
-UN-22DEC89

3. Install front cap screw and nut.



M21,7010S,R -19-24DEC85

M50232  
-UN-22DEC89

4. Tighten all nuts on left plate.



M21,7010S,S -19-24DEC85

M50231  
-UN-22DEC89

5. Install right and left snap rings.



M21,7010S,T -19-24DEC85

M50230  
-UN-22DEC89

## Mower Lift Linkage/Lift Lever Assembly

6. Install lift spring and bracket.
7. Install washer and spring pin. Rotate bracket (A) to horizontal position.
8. Install platform, control knobs, and pedestal shroud.
9. Install mower.



M21,7010S,U -19-27MAR85

M50228 -UN-22DEC89



LAWN TRACTOR SERVICE INFORMATION BULLETINS

1988-

SIB-M88-12-1 BM16661 rear bagging attachmant and BM16659 power flow will not fit new style 38-inch mower deck. 160, 165, 175, 180 and 185 lawn tractors.

1987-

SIB-M87-12-11 Parking brake does not release, 130, 160, 165, 175, 180 and 185 lawn tractors.

SIB-M87-12-10 PTO clutch falls off of crankshaft.

SIM-M87-12-9 Ground speed is erratic. Lawn tractors:

111(M00111S 095,001—360,000)	130 (M00130X 360,001— )
116 (46-inch) (M00116B 190,001—360,000)	160 (M00160T 360,001— )
116 (38-inch) (M00116A 222,001—360,000)	180 (M00180 (A and B) 360,001— )
108 (M00108X 095,001— )	

M87-12-8 10-blade hydrostatic cooling fan breaks. 111H, 116H, 112L, 165, 175, 185 (SN—475,000) lawn tractors.

M87-12-6 Jacksheave bearing and pivot stud fail.

111 (M00111S 095,001— )	160 (M00160T—420,000)
111H (M00111H 195,001— )	165 (M00165X—420,000)
112L (M00116A 222,001— )	180 (M00185A—420,000)
116 (M00116A 222,001— )	185 (M00633X—555,000)
116H (M00116C 232,001— )	38 ATRM (M00633X—555,000)

SIB-M87-12-5 LT-Kawasaki engine surges.

130 (M00130X 360,001— )	112L (M0112LX 315,001— )
160 (M00160T 360,001— )	180 (M00180 (A and B) 360,001— )
165 (M00165X 360,001— )	
175 (M00175X 420,001— )	

SIB-M87-12-4 LT battery goes dead/no charging system output.

130 (M00130X 360,001— )	165 (M00165X 360,001— )
160 (M00160T 360,001— )	175 (M00175X 420,001— )
180 (M00180 (A and B) 360,001— )	185 (M00185 A and B) 360,001— )

SIB-M87-12-3 Steering pedestal support interferes with AM101001 oil filter kit.

160 (M00160T 360,001—420,000)  
156 (M00165X 360,001—420,000)

SIB-M87-12-2 Erratic hydrostatic transmission operation.

165 (M00165X 360,001— )	175 (M00175X 420,001— )
185/38-inch (M00185A 360,001— )	185/46-inch (M00185B 360,001— )

1986-

SIB-M86-12-6 Fender deck mounting bolts break at low hours.

130 (363,085—363,361)	180/38-inch (362,692—362,785)
160 (374,483—374,920)	180/46-inch (369,004—369,173)
165 (371,377—372,030)	185/38-inch (375,146—375,235)
	185/46-inch (382,293—382,406)

Mower Lift Linkage/Lift Lever Assembly

1986 CONT.—

- SIB-M86-12-2 Leveling the frame on 1986 model lawn tractors.  
130 (360,001— ) 180 (A360,001— )  
160 (360,001— ) 180 (B360,001— )  
165 (360,001— ) 185 (B360,001— )
- SIB-M86-12-1 Steering pedestal reinforcement brace installation.  
130 (360,001—360,060) 180/38-inch (A360,001—362,140)  
160 (360,001—369,585) 180/46-inch (B360,001—367,927)  
165 (360,001—367,317) 185/38-inch (A372,001—374,378)  
185/46-inch (B378,001—380,205)
- SIB-M86-20-10 Bagger chute comes off 30-inch mower deck on R and S series riding mowers and 100 series tractors.

1985—

- SIB-M85-12-4 Installation of jacksheave bearing on 38-inch and 46-inch mowers. (Lawn tractors SN-420,000).
- SIB-M85-12-1 Oil filter kit AM101001-112L LT.
- SIB-M85-20-12 New hoppertop windows. Rear grass-bagging attachment for lawn tractors.

1984—

- SIB-M85-20-15 Rear grass bag attachment—6—1/2 bushel. Grass and/or debris os blown out between cover and bags.

MX.INFO2 -19-24MAY89

80  
10  
8

**Section 210**

# **SPECIFICATIONS/OPERATIONAL CHECKOUT PROCEDURE**

## **Contents**

**Page**

**Group 01—Test and Adjustment**

Specifications . . . . . 210-01-1

**Group 05—Machine Operational Checkout**

Dash Lamp Check . . . . . 210-05-1

Transmission Neutral Start Check . . . . . 210-05-1

PTO/Safety Start Check . . . . . 210-05-2

Starting Circuit Check (Hydrostatic) . . . . . 210-05-2

Starting Circuit Check (Gear) . . . . . 210-05-2

Indicator Lamp Running Check . . . . . 210-05-2

Throttle and Choke Lever Check . . . . . 210-05-2

Brake Pedal Lock Check . . . . . 210-05-2

Seat Switch Check for PTO and Ignition . 210-05-3

Transmission Forward-Reverse Check . . . 210-05-3

Transmission Neutral Check . . . . . 210-05-3

Brake Neutral Return Check . . . . . 210-05-4

headlight Check . . . . . 210-05-4



## ENGINE

Fast Idle Speed . . . . .	3350 ± 100
Slow Idle Speed . . . . .	1400 ± 100
Cylinder Compression-Minimum	
160 and 165 . . . . .	380 kPa (55 psi)
130, 175, 180, and 185 . . . . .	483 kPa (71 psi)
Crankcase Vacuum-Minimum	
130 . . . . .	7 cm (2.8 in. water)
160, 165, 175, 180, and 185 . . . . .	25 cm (9.8 in. water)
Oil Pressure-Minimum . . . . .	240 kPa (35 psi)
Fuel Pump Pressure-Minimum	
160 and 165 . . . . .	3.68 kPa (0.5 psi)
130, 175, 180, and 185 . . . . .	6.12 kPa (0.9 psi)
Fuel Pump Flow-Minimum	
130 and 175 . . . . .	80 ml/15 seconds (2.7 oz/15 seconds)
160, 165, 180, and 185 . . . . .	90 ml/15 seconds (3 oz./15 seconds)
Spark Plug Gap	
130, 175, 180, and 185 . . . . .	0.7-0.8 mm (0.028-0.031 in.)
160 and 165 . . . . .	0.6-0.7 mm (0.024-0.028 in.)

## ELECTRICAL SYSTEM

Ignition Coil Air Gap . . . . .	0.3 mm (0.12 in.)
Ignition Coil Resistance	
Primary . . . . .	0.4-0.8 ohms
Secondary . . . . .	10,000-18,000 ohms
Starter Amp Draw-Maximum . . . . .	150 amps
Starter No-Load RPM-Minimum	
130 . . . . .	7000 rpm
160, 165, 175, 180, and 185 . . . . .	6000 rpm
Starter No-Load Amperage-Maximum	
130 . . . . .	60 amps
160, 165, 175, 180, and 185 . . . . .	50 amps
Regulated Output at 12.2-13.8V	
130 . . . . .	12 amps minimum
160, 165, 175, 180, and 185 . . . . .	14 amps minimum
Unregulated Voltage Output-Minimum . . . . .	34V

M21,SPEC -19-24MAY89

210  
01  
1

210  
01  
2

## BEFORE YOU START

This operational diagnostics procedure is designed for you to perform a quick check of the machine in a step-by-step method.

We recommend you perform these checks of the entire machine. These checks refer you to a specific system on the machine for a more detailed step-by-step method of resolving machine problems. These procedures also provide you with a method to evaluate trade-in equipment and perform an annual checkout.

A large majority of typical machine problems can be resolved using operational diagnostics with your sense of look, listen and feel.

Perform these checks on a level surface. No special tools or equipment are required.

Begin with step one and read from left to right. Read the step completely before performing the check.

Do the entire procedure before continuing on to another section and correction of the indicated problem. Once the machine checkout is complete, turn to the appropriate sections in this manual.

M21,21005S,1 -19-10OCT86

### 1 DASH LAMP CHECK

*NOTE: For tractors not equipped with indicator lamps, GO TO 2*

Transmission in neutral.  
PTO switch OFF.  
Key switch ON.



M43593 -UN-12JAN90

*LOOK: Oil pressure lamp and battery discharge lamp should be on (if equipped). Low fuel lamp will only come on if fuel level is low.*

**OK: GO TO 2**

**NOT OK:**  
GO TO SECTION 240.

M21,21005S,2 -19-10OCT86

### 2 TRANSMISSION NEUTRAL START CHECK

Operator on seat.

**CAUTION:** Be aware that if neutral start circuit is defective, tractor will start and move forward.



M43594 -UN-12JAN90

Put hydrostatic lever in slow forward, or gear selector level in first gear forward.

Turn key switch to START.

*LISTEN: Starter must NOT crank engine.*





**OK: GO TO 3**

**NOT OK:**  
GO TO SECTION 240.

M21,21005S,3 -19-13OCT86

210  
05  
1

Machine Operational Checkout/Brake Pedal Lock Check

<p><b>3 PTO/SAFETY START CHECK</b></p> <p>Operator on seat. Fully depress brake pedal.</p>	<p><b>⚠ CAUTION:</b> Be aware that if PTO neutral start circuit is defective, tractor will start and PTO will engage.</p>	 <p>M43595 -UN-12JAN90</p>	<p>Turn PTO switch ON.</p> <p>Turn key switch to START.</p> <p><i>LISTEN: Starter must NOT crank engine.</i></p>	<p><b>OK:</b> GO TO <b>4</b></p> <p><b>NOT OK:</b> GO TO SECTION 240.</p> <p>M21,21005S,4 -19-13OCT86</p>
<p><b>4 STARTING CIRCUIT CHECK FOR HYDROSTATIC TRACTORS.</b></p> <p><i>NOTE: Gear tractors, GO TO 4A</i></p>	<p>Sit on seat.</p>	 <p>M43596 -UN-12JAN90</p>	<p>Fully depress brake pedal.</p> <p>Turn key switch to START.</p> <p><i>LISTEN: Starter must crank engine. Engine must start.</i></p>	<p><b>OK:</b> GO TO <b>5</b></p> <p><b>NOT OK:</b> GO TO SECTION 240.</p> <p>M21,21005S,5 -19-10DEC86</p>
<p><b>4A STARTING CIRCUIT CHECK FOR GEAR TRACTORS.</b></p>	<p>Transmission in neutral. Park brake set.</p>	 <p>M43597 -UN-12JAN90</p>	<p>Turn key switch to START.</p> <p><i>LISTEN: Starter must crank engine. Engine must start.</i></p>	<p><b>OK:</b> GO TO <b>5</b></p> <p><b>NOT OK:</b> GO TO SECTION 240.</p> <p>M21,21005S,6 -19-10DEC86</p>
<p><b>5 INDICATOR LAMP RUNNING CHECK</b></p> <p><i>NOTE: If not equipped with indicator lamps, GO TO 6</i></p>	<p>Start engine and run at full throttle.</p>	 <p>M43598 -UN-12JAN90</p>	<p><i>LOOK: Battery discharge lamp must be OFF.</i></p> <p><i>Oil pressure lamp must be OFF.</i></p>	<p><b>OK:</b> GO TO <b>6</b></p> <p><b>NOT OK:</b> GO TO SECTION 240.</p> <p>M21,21005S,7 -19-13OCT86</p>
<p><b>6 THROTTLE AND CHOKE LEVER CHECK</b></p> <p>Accelerate engine from slow to fast idle.</p>	<p><i>LISTEN: Engine must accelerate smoothly without hesitation.</i></p>	 <p>M43599 -UN-12JAN90</p>	<p>Push throttle lever past detent to choke position, then return to fast idle.</p> <p><i>LISTEN: Engine must falter, then resume speed.</i></p>	<p><b>OK:</b> GO TO <b>7</b></p> <p><b>NOT OK:</b> GO TO SECTION 220.</p> <p>M21,21005S,8 -19-13OCT86</p>
<p><b>7 BRAKE PEDAL LOCK CHECK</b></p>	 <p>M43600 -UN-12JAN90</p>	<p>Move lever (A) down toward lock position.</p> <p>GEAR TRACTORS: Depress both brake and clutch pedals together.</p> <p>HYDROSTATIC TRACTORS: Depress brake pedal fully.</p>	<p><b>Continued on next page</b></p>	

210  
05  
2



*Machine Operational Checkout/Transmission Neutral Check*

<p><i>LOOK: Pedals must stay engaged.</i></p> <p>Depress pedals fully. Pull lever up to unlock position and release pedals.</p> <p><i>LOOK: Pedals must return to normal position.</i></p>	<p><b>OK:</b> GO TO 8</p> <p><b>NOT OK:</b> GO TO SECTION 250.</p> <p align="right"><small>M21,21005S,9 -19-20JAN87</small></p>
--	---

<p><b>8 PTO CHECK</b></p>	<p>Sit on a seat. Engine OFF. Turn key switch ON.</p>	 <p align="center"><small>M43595 -UN-12JAN90</small></p>	<p>Turn PTO switch ON.</p> <p><i>LISTEN: PTO must click ON.</i></p>	<p><b>OK:</b> GO TO 9</p> <p><b>NOT OK:</b> GO TO SECTION 240.</p> <p align="right"><small>M21,21005S,10 -19-13OCT86</small></p>
---------------------------	---	---	---	--

<p><b>9 SEAT SWITCH CHECK FOR PTO AND IGNITION</b></p>	<p>Sit on seat. Run engine at half throttle.</p>	 <p align="center"><small>M43595 -UN-12JAN90</small></p>	<p>Turn PTO switch ON.</p> <p>Raise up off seat.</p> <p><i>LISTEN: Engine must stop.</i></p>	<p><b>OK:</b> GO TO 10</p> <p><b>NOT OK:</b> GO TO SECTION 240.</p> <p align="right"><small>M21,21005S,11 -19-13OCT86</small></p>
--	--	--	--	---

<p><b>10 TRANSMISSION FORWARD-REVERSE CHECK</b></p> <p>Run engine at full throttle.</p>	 <p align="center"><small>M43601 -UN-12JAN90</small></p>	<p><b>HYDROSTATIC TRACTORS:</b> Move lever to full forward and reverse.</p> <p><b>GEAR TRACTORS:</b> Shift through all forward gears and reverse. (Hydrostatic transmission shown.)</p>
---	---	---

<p><i>FEEL: Tractor must accelerate smoothly in all speeds forward and reverse.</i></p>	<p><b>GEAR TRACTORS OK:</b> Checkout procedure complete.</p> <p><b>HYDROSTATIC TRACTORS OK:</b> GO TO 11</p> <p><b>NOT OK:</b> GO TO SECTION 250</p> <p align="right"><small>M21,21005S,12 -19-20JAN87</small></p>
---	--

<p><b>11 TRANSMISSION NEUTRAL CHECK FOR HYDROSTATIC TRACTORS ONLY.</b></p>	<p>Run engine about 3/4 throttle. Brake OFF.</p>	 <p align="center"><small>M43602 -UN-12JAN90</small></p>	<p>Leave transmission lever in neutral.</p> <p><i>LOOK: Tractor must not creep forward or reverse.</i></p>	<p><b>OK:</b> GO TO 12</p> <p><b>NOT OK:</b> GO TO SECTION 250.</p> <p align="right"><small>M21,21005S,13 -19-20JAN87</small></p>
--	--	---	--	---

Machine Operational Checkout/headlight Check

<p><b>12</b> BRAKE NEUTRAL RETURN CHECK FOR HYDROSTATIC TRACTORS ONLY.</p>	<p>Engine off. Transmission lever full forward.</p>	 <p>Depress brake pedal firmly.</p> <p><i>LOOK: Transmission lever must return to neutral, tractor must stop.</i></p>	<p><b>OK: GO TO 13</b></p> <p><b>NOT OK:</b> GO TO SECTION 250.</p>
--	---	--	---

M43596 -UN-12JAN90

M21,21005S,14 -19-21JAN87

<p><b>13</b> HEADLIGHT CHECK (175, 180, and 185 Tractors)</p> <p>(Other Models If Equipped.)</p>	<p>Key switch ON. Pull light switch out.</p>	 <p><i>LOOK: Headlights must be ON.</i></p> <p>BLK;</p> <p><b>OK:</b> Checkout procedure complete. Machine OK.</p> <p><b>NOT OK:</b> GO TO SECTION 240.</p>	
--	--	--	--

M49133 -UN-20DEC89

042,M49133 -19-23MAY89

# Section 220 ENGINE/FUEL OPERATION AND TESTS

## Contents

### Page

#### Group 05—Engine System Checkout

Engine Oil Leak Check . . . . .	220-05-1
Fuel Leak Check . . . . .	220-05-1
Air Cleaner and Air intake Screen Check . . . . .	220-05-1
Throttle Lever Check . . . . .	220-05-2
Engine Start Check . . . . .	220-05-2
Choke Linkage Check . . . . .	220-05-2
Engine Oil Pressure Check . . . . .	220-05-2
Engine Performance Check . . . . .	220-05-2
Engien Load Performance Check . . . . .	220-05-3

#### Group 10—Engine System Diagnosis

Engine Problem Identification . . . . .	220-10-2
Throttle Cable Adjustment . . . . .	220-10-8
Choke Adjustment . . . . .	220-10-8
Governor Adjustment . . . . .	220-10-9
Fast Idle Speed Adjustment . . . . .	220-10-9
Slow Idle Speed Adjustment . . . . .	220-10-10
Cylinder Compression Test . . . . .	220-10-10
Crankcase Vacuum Test . . . . .	220-10-11
Oil Pressure Test . . . . .	220-10-11
Fuel Pump Test . . . . .	220-10-12
Ignition Spark Test . . . . .	220-10-13
Carburetor Cleaning Procedure . . . . .	220-10-13



## BEFORE YOU START

Always begin with this group to identify a failure in the engine system. The step-by-step procedure will provide you with a quick check of the system. No tools are required to perform these checks. If a failure is indicated, you will be referred to a more detailed check, adjustment, or test.

This procedure is designed as a quick check of the system. While performing the check, concentrate only on the check you are performing and disregard signals from unrelated components.

Always start with the first step and follow the sequence from left to right. Read each step completely before performing the check.

M21,22005S,1 -19-13OCT86

### 1 ENGINE OIL LEAK CHECK

Check engine oil level, condition, and viscosity.



M43655 -UN-31AUG88

Inspect for external engine oil leakage from oil pressure sensor, oil filter, oil filter adapter, engine base gasket, dipstick tube, and drain plug.

*NOTE: Oil filter is not used on 130 Tractor and optional on 160 and 165 Tractors and early model 175.*

**OK:** GO TO 2

**NOT OK:** Repair or replace, then ... GO TO 2

M21,22005S,2 -19-13OCT86

### 2 FUEL LEAK CHECK



M43656 -UN-12JAN90

Inspect for external fuel leakage from fuel tank, fuel pump, fuel filter, carburetor, fuel lines and fittings.

**OK:** GO TO 3

**NOT OK:** Repair or replace, then ... GO TO 3

M21,22005S,3 -19-02FEB87

### 3 AIR CLEANER AND AIR INTAKE SCREEN CHECK

Remove air cleaner cover.



M43657 -UN-31AUG88



M43658 -UN-31AUG88

Inspect precleaner, filter element, and air intake screen for debris or plugged condition.





**OK:** GO TO 4

**NOT OK:** Clean or replace, then... GO TO 4

M21,22005S,4 -19-02FEB87

220  
05  
1

## Engine System Checkout/Engine Performance Check

<p><b>4 THROTTLE LEVER CHECK</b></p>	 <p>M43676 -UN-12JAN90</p>	<p>Move throttle lever from low idle position to high idle position.</p> <p><i>LOOK: Throttle lever must contact stop in the dash at high idle position.</i></p>	<p>FEEL; Throttle lever must move smoothly from low to high idle position with slight friction.</p>	<p><b>OK: GO TO 5</b></p> <p><b>NOT OK: GO TO 2</b> GROUP 10.</p> <p>M21,22005S,5 -19-02FEB87</p>
<p><b>5 ENGINE START CHECK</b></p> <p>Put transmission lever in neutral position.</p>	<p>Put PTO switch in OFF position.</p> <p>Move throttle lever to choke position.</p> <p>Depress brake pedal.</p>	 <p>M43597 -UN-12JAN90</p>	<p>Turn key switch to START position.</p> <p>Starter must crank engine. Engine must start.</p>	<p><b>OK: GO TO 6</b></p> <p><b>NOT OK: GO TO 1</b> GROUP 10.</p> <p>M21,22005S,6 -19-20JAN87</p>
<p><b>6 CHOKE LINKAGE CHECK</b></p>	 <p>M43599 -UN-12JAN90</p>	<p>Run engine at half throttle.</p> <p>Quickly move throttle lever to choke position, then to run position.</p>	<p><i>LISTEN: Engine must falter, then resume speed.</i></p>	<p><b>OK: GO TO 7</b></p> <p><b>NOT OK: GO TO 3</b> GROUP 10.</p> <p>M21,22005S,7 -19-20JAN87</p>
<p><b>7 ENGINE OIL PRESSURE CHECK</b></p> <p><i>NOTE: This check is only for late model 175's and all 180 and 185 Tractors.</i></p>	 <p>M43677 -UN-12JAN90</p>	<p>Run engine at full throttle.</p> <p><i>LOOK: Oil pressure lamp must go OFF.</i></p>	<p><i>LOOK: Engine oil must not leak from oil filter or adapter gaskets.</i></p> <p><i>Exhaust smoke must not be blue.</i></p>	<p><b>OK: GO TO 8</b></p> <p><b>NOT OK: GO TO 9</b> GROUP 10.</p> <p>M21,22005S,8 -19-20JAN87</p>
<p><b>8 ENGINE PERFORMANCE CHECK</b></p> <p>Move throttle lever from slow idle to fast idle position.</p>	 <p>M43676 -UN-12JAN90</p>	<p><i>LISTEN: Engine must accelerate smoothly, without hesitation.</i></p> <p><i>LOOK: Exhaust gas must be clear.</i></p>	<p><i>LISTEN: Governor must hold engine at a constant rpm and not surge.</i></p> <p><i>LISTEN: Engine must not make any abnormal sounds or backfire.</i></p>	<p><b>OK: GO TO 9</b></p> <p><b>NOT OK: GO TO 1</b> GROUP 10.</p> <p>M21,22005S,9 -19-20JAN87</p>

Engine System Checkout/Engien Load Performance Check

**9** ENGINE LOAD PERFORMANCE CHECK



M43595 -UN-12JAN90

Engage PTO lever. Move throttle lever to fast idle position. Mow tall grass, if possible, to load engine.

*LISTEN: Governor must increase and decrease engine rpm smoothly to match load conditions.*

*LOOK: Exhaust gas must be clear.*

*LISTEN: Engine must not make any abnormal sounds or backfire. Engine must not hesitate or stumble.*

**OK:** System normal.

**NOT OK:** GO TO **1** GROUP 10.

M21,22005S,10 -19-20JAN87

**10** OPERATOR COMPLAINT NOT IDENTIFIED.

If you completed the checkout procedure and did not isolate a malfunction, the problem may be intermittent.

Try to duplicate the conditions of the malfunction identified by the operator.

REPEAT THE ENGINE SYSTEM CHECKOUT PROCEDURE IN THIS GROUP.

IF MALFUNCTION IS NOT IDENTIFIED AFTER REPEATING ENGINE SYSTEM CHECKOUT PROCEDURE: FACTORY ASSISTANCE IS AVAILABLE THROUGH THE DEALER TECHNICAL ASSISTANCE CENTER (DTAC).

M21,22005S,11 -19-20JAN87

220  
05  
3

*Engine System Checkout/Engien Load Performance Check*

220  
05  
4



## BEFORE YOU START

Always perform the system checkout procedure in Group 05 BEFORE making any tests or adjustments in this group. The step-by-step procedures in this group provide you with the detailed diagnostic information you will need to isolate a malfunction. Basic diagnostic equipment is used.

It is assumed that you are familiar with the machine and its engine and fuel system components.

Engine rpm and temperature are critical in most engine tests. Be sure to follow test specifications carefully.

Always start with the first step and follow the sequence from left to right. Read each step completely before performing the check.

Upon completing a test or adjustment, check to see whether the problem is corrected by performing the checkout procedure in Group 05.

M21.22010,1 -19-24MAY89

220  
10  
1

Engine System Diagnosis/Engine Problem Identification

<p><b>1 ENGINE PROBLEM IDENTIFICATION</b></p> <p>If engine does not operate properly, select the appropriate symptom/problem from list at right.</p> <p>After selecting the appropriate symptom or problem, go to that step and perform the checks, tests, or adjustments in the order shown to isolate and repair malfunction.</p> <p>If engine does not crank, see Section 240.</p>		<p>ENGINE WILL NOT START: GO TO <b>A</b></p> <p>ENGINE STARTS HARD WHEN COLD, HOT, SITTING OR ENGINE KILLS WHEN HOT (HAS SPARK): GO TO <b>B</b></p> <p>ENGINE SURGES OR SURGES AT FAST IDLE WITH NO LOAD: GO TO <b>C</b></p> <p>ENGINE SURGES (NEW UNIT): GO TO <b>D</b></p> <p>ENGINE BACKFIRES WHEN STARTING OR BACKFIRES THROUGH CARBURETOR: GO TO <b>E</b></p> <p>ENGINE BACKFIRES THROUGH MUFFLER WHEN SHUT OFF: GO TO <b>F</b></p> <p>ENGINE MISSES: GO TO <b>G</b></p> <p>ENGINE LOSES POWER OR RUNS ROUGH WHEN HOT: GO TO <b>H</b></p> <p>ENGINE KNOCKS AT SLOW IDLE: GO TO <b>I</b></p> <p>ENGINE KNOCKS OR VIBRATES AT FAST IDLE: GO TO <b>J</b></p> <p>ENGINE OIL LEVEL INCREASES OR GAS IN OIL: GO TO <b>K</b></p> <p>ENGINE CONTINUES TO RUN (DIESELS) AFTER KEY IS SHUT OFF: GO TO <b>L</b></p>	<p>ENGINE KILLS WHEN PTO IS ENGAGED: See Section 240.</p> <p>ENGINE KILLS WHEN TRANSMISSION LEVER IS MOVED OUT OF NEUTRAL: See Section 240.</p> <p>ENGINE OVERHEATS: GO TO <b>M</b></p> <p>ENGINE HAS BLACK EXHAUST SMOKE: GO TO <b>N</b></p> <p>ENGINE HAS BLUE EXHAUST SMOKE OR OIL IN AIR CLEANER: GO TO <b>O</b></p> <p>ENGINE USES TOO MUCH OIL: GO TO <b>P</b></p> <p>ENGINE USES TOO MUCH FUEL: GO TO <b>Q</b></p>
---	--	---	---

M21,22010,2 -19-24MAY89

<p><b>A Engine Will Not Start</b></p>	<p>Drain fuel and replace with fresh fuel.</p> <p>Test ignition spark. GO TO <b>11</b></p> <p>Test fuel transfer pump output. GO TO <b>10</b></p> <p>Inspect and adjust throttle cable: GO TO <b>2</b></p> <p>Inspect and adjust choke. GO TO <b>3</b></p> <p>Adjust carburetor idle mixture screw. GO TO <b>6</b></p> <p>Check and adjust governor linkage. GO TO <b>4</b></p> <p>Check carburetor float adjustment.</p>	<p>See CTM-5.</p> <p>Check starter cranking RPM: See Section 240.</p> <p>Test compression: GO TO <b>7</b></p> <p>Test crankcase vacuum: GO TO <b>8</b></p> <p>Check and adjust valve clearance. See CTM-5.</p>
---------------------------------------	---	--

M21,22010,3 -19-23MAY89

220  
10  
2

<p><b>B</b> Engine Starts Hard When Cold, Hot, Sitting or Engine Kills When Hot (Has Spark)</p>	<p>Test ignition spark for hot "blue" spark: GO TO <b>11</b></p> <p>Drain fuel and replace with fresh fuel.</p> <p>Test fuel transfer pump output. GO TO <b>10</b></p> <p>Inspect and adjust throttle cable: GO TO <b>2</b></p> <p>Inspect and adjust choke. GO TO <b>3</b></p> <p>Check carburetor float adjustment. See CTM-5.</p> <p>Check starter cranking RPM: See Section 240.</p>	<p>Test compression: GO TO <b>7</b></p> <p>Check and adjust valve clearance. see CTM-5.</p> <p>Test ignition system. See Section 240.</p> <p>Check flywheel key for partially sheared condition.</p> <p>Check PTO clutch for dragging.</p>
---	--	--

M21.22010,4 -19-25MAY89

<p><b>C</b> Engine Surges Or Surges At Fast Idle With No Load</p> <p>Kawasaki engine surge is a common complaint most often caused by plugged engine cooling fins, plugged carburetor, or misadjusted carburetor.</p> <p><b>IMPORTANT:</b> Carburetors are very sensitive to adjustment, take time to make all adjustments exactly as instructed.</p>	<p>Drain fuel and replace with fresh fuel.</p> <p>With engine running, remove air cleaner cover. If surging stops, engine cooling fins or air filter are plugged. Remove engine shrouding and clean cooling fins. Check screen to blower housing clearance: See CTM-5. If surging does not stop with cover removed. Install cover and continue testing.</p> <p>Inspect and adjust throttle cable: GO TO <b>2</b></p> <p>Inspect and adjust choke: GO TO <b>3</b></p> <p>Inspect and adjust governor: GO TO <b>4</b></p> <p>Adjust carburetor idle mixture screw and slow idle: GO TO <b>6</b></p> <p>Adjust fast idle: GO TO <b>5</b></p> <p>Inspect carburetor for plugged condition from varnish deposits: GO TO <b>12</b></p> <p>Check carburetor float adjustment.</p>	<p>See CTM-5.</p> <p>Check for air intake leak. Verify by spraying aerosol lubricant (such as WD-40) around carburetor mating surfaces and intake manifold.</p> <p>Check fuel tank vent for plugged condition.</p> <p>Test fuel pump output: GO TO <b>10</b></p> <p>Check and adjust valve clearance. See CTM-5.</p> <p>Test crankcase vacuum: GO TO <b>8</b></p> <p>If engine was disassembled, check static timing. See CTM-5.</p>
---	--	--

M21.22010,5 -19-25MAY89

220  
10  
3

<p><b>D Engine Surges</b></p>	<p>Inspect carburetor for plugged condition from varnish deposits (common on New Tractors): GO TO <b>12</b></p> <p>Check carburetor float adjustment. See CTM-5.</p> <p>Inspect and adjust throttle cable: GO TO <b>2</b></p> <p>Inspect and adjust choke: GO TO <b>3</b></p> <p>Inspect and adjust governor: GO TO <b>4</b></p> <p>Adjust carburetor idle mixture screw and slow idle: GO TO <b>6</b></p> <p>Adjust fast idle: GO TO <b>5</b></p> <p style="text-align: right;">M21.22010.6 -19-25MAY89</p>
-------------------------------	--

<p><b>E Engine Backfires When Starting Or Backfires Through Carburetor</b></p>	<p>Check spark plug for fouled condition.</p> <p>Test ignition spark for hot "blue" spark: GO TO <b>11</b></p> <p>Inspect and adjust choke: GO TO <b>3</b></p> <p>Adjust carburetor idle mixture screw: GO TO <b>6</b></p> <p>Check carburetor float adjustment: See CTM-5.</p> <p>Check and adjust ignition coil air gap. See Section 240.</p> <p>Test igniter. see Section 240.</p> <p>Check for sticking valves. See</p> <p>CTM-5.</p> <p>Check and adjust valve clearance. See CTM5.</p> <p>Check flywheel key for partially sheared condition.</p> <p style="text-align: right;">M21.22010.7 -19-25MAY89</p>
--	---

<p><b>F Engine Backfires Through Muffler When Shut Off</b></p>	<p>Check air cleaner for plugged condition.</p> <p>Adjust carburetor idle mixture screw: GO TO <b>6</b></p> <p>Check carburetor float adjustment: See CTM-5.</p> <p>Check and adjust slow idle speed: GO TO <b>6</b></p> <p>Check and adjust ignition coil air gap. See Section 240.</p> <p>Replace muffler.</p> <p style="text-align: right;">M21.22010.8 -19-25MAY89</p>
--	--

220  
10  
4

Engine System Diagnosis/Engine Problem Identification

<p><b>G Engine Misses</b></p>	<p>Check type and condition of fuel.</p> <p>Check spark plug for fouled condition and proper gap.</p> <p>Check spark plug wire for wet or deteriorated condition.</p> <p>Adjust carburetor idle mixture screw: GO TO <b>6</b></p> <p>Check carburetor float adjustment: See CTM-5.</p> <p>Check and adjust ignition coil air gap. See Section 240.</p> <p>Test ignition coil. See Section 240.</p> <p>Test igniter. See Section 240.</p>	<p>Test engine compression. GO TO <b>7</b></p> <p>Check and adjust valve clearance. See CTM-5.</p> <p>Check flywheel key for partially sheared condition.</p>
-------------------------------	--	---

M21,22010,9 -19-25MAY89

<p><b>H Engine Loses Power Or Runs Rough When Hot</b></p>	<p>Check air cleaner for plugged condition.</p> <p>Check fuel tank vent, line and screen for plugged condition.</p> <p>Test fuel pump output: GO TO <b>10</b></p> <p>Inspect and adjust governor: GO TO <b>4</b></p> <p>Inspect carburetor for plugged passages.</p> <p>Check carburetor float adjustment. See CTM-5.</p> <p>Test engine compression: GO TO <b>7</b></p> <p>Check and adjust valve clearance: See CTM-5.</p> <p>Check muffler for restriction or plugged condition.</p>
---	---

M21,22010,10 -19-25MAY89

<p><b>I Engine Knocks At Slow Idle</b></p> <p>Kawasaki engine knock at low engine rpm is a common complaint most often caused by camshaft gear backlash. Camshaft gear backlash is not a functional problem and will not affect the performance or life of</p>	<p>the engine.</p> <p>The slight "metallic" knock is considered normal and does not require engine repair or adjustment.</p>	<p>Continued on next page</p>
--	--	-------------------------------

220  
10  
5

*Engine System Diagnosis/Engine Problem Identification*

<p>A knocking noise produced by camshaft gear backlash will have the following characteristics: "Metallic" knocking noise at low rpm. Knock disappears as rpm increases. Knock does not get worse with time.</p> <p>Knock is more noticeable near the dipstick by the camshaft.</p> <p>Try to determine the location of engine knock with a sound amplifying device.</p>	<p><b>OTHER ITEMS TO CHECK IF ENGINE KNOCKS:</b></p> <p>Check fuel condition. Replace with fresh fuel.</p> <p>Check for engine overheating from plugged cooling fins.</p> <p>Check PTO clutch for vibration against stop pin.</p> <p>Check flywheel key for partially sheared condition.</p> <p>Check for carbon build-up in combustion chamber.</p> <p>Check and adjust valve clearance. See CTM-5.</p>	<p>Check and adjust crankshaft end play. See CTM-5.</p> <p>Check cylinder bore and rings for wear. See CTM-5.</p> <p>Check for loose or worn connecting rods. See CTM-5.</p> <p>Check for worn crankshaft or camshaft bearings. See CTM-5.</p>
--	--	--

M21,22010,11 -19-25MAY89

<p><b>J Engine Knocks Or Vibrates At Fast Idle</b></p>	<p>If engine has an inconsistent knock, vibration or "clunking" noise that gets worse as engine rpm increases, check the following:</p> <p>Check PTO clutch for vibration against stop pin.</p> <p>Check and adjust crankshaft end</p>	<p>play. See CTM-5.</p> <p>Check for worn counterweight bushing or support shaft. See CTM-5.</p> <p>Check for worn counterweight link bushings. See CTM-5.</p>
--	--	--

M21,22010,12 -19-25MAY89

<p><b>K Engine Oil Level Increases Or Gas In Oil</b></p>	<p>Check fuel shut off valve for leakage; close valve when storing.</p> <p>Check fuel pump diaphragm for leaks.</p> <p>Check carburetor needle valve and seat for wear or damage.</p>	<p>Check and adjust carburetor float level. See CTM-5.</p> <p>Inspect carburetor body for porosity.</p> <p>Test fuel pump output: GO TO <b>10</b></p>
--	---	---

M21,22010,13 -19-25MAY89

<p><b>L Engine Continues To Run (Diesels) After Key Is Shut off</b></p>	<p>Check fuel condition. Replace with fresh fuel.</p> <p>Check and adjust slow idle: GO TO <b>6</b></p> <p>Check for carbon build-up in combustion chamber.</p> <p>Check and adjust valve clearance. See CTM-5.</p>
---	---

M21,22010,14 -19-25MAY89

220  
10  
6

Engine System Diagnosis/Engine Problem Identification

<p><b>M</b> Engine Overheats</p>	<p>Check cooling fins for debris.</p> <p>Check oil level.</p> <p>Test engine oil pressure: GO TO 9</p> <p>Adjust carburetor idle mixture screw: GO TO 6</p> <p>Adjust governor: GO TO 4</p> <p>Adjust fast idle: GO TO 5</p> <p>Check flywheel key for partially sheared condition.</p> <p>Check for carbon build-up in combustion chamber.</p> <p>Check muffler for restriction or</p>	<p>plugged condition.</p> <p>Check connecting rod to crankshaft bearing clearance and crankshaft to main bearing clearance. See CTM-5.</p>
<p><b>N</b> Engine Has Black Exhaust Smoke</p>	<p>Check air cleaner for debris.</p> <p>Check oil fill dipstick O-ring seal or cracked cap.</p> <p>Inspect and adjust choke: GO TO 3</p> <p>Inspect carburetor needle valve and seat for wear or damage.</p>	<p>Check and adjust carburetor float level. See CTM-5.</p> <p>Check for correct main jet for elevation. See Parts Catalog for size and elevation.</p> <p>Test fuel pump output. GO TO 10</p>
<p><b>O</b> Engine Has Blue Exhaust Smoke Or Oil In Air Cleaner</p>	<p>Test crankcase vacuum: GO TO 8</p> <p>Check breather reed valve clearance. See CTM-5.</p> <p>Check tappet chamber oil drain hole for plugged condition.</p> <p>Test engine compression: GO TO 7</p>	<p>Check valve guides for wear or damage. See CTM-5.</p> <p>Check piston rings for wear or damage. See CTM-5.</p>
<p><b>P</b> Engine Uses Too Much Oil</p>	<p>Test crankcase vacuum: GO TO 8</p> <p>Check breather reed valve clearance. See CTM-5.</p> <p>Check tappet chamber oil drain hole for plugged condition.</p> <p>Check oil seals and gaskets for leakage.</p> <p>Test engine compression: GO TO 7</p> <p>Check valve guides for wear or damage. See CTM-5.</p> <p>Check piston rings for wear or damage. See CTM-5.</p> <p>Check cylinder bore for wear or</p>	<p>damage. See CTM-5.</p> <p>Check connecting rod to crankshaft bearing clearance. See CTM-5.</p>

M21,22010,15 -19-25MAY89

M21,22010,16 -19-25MAY89

M21,22010,17 -19-25MAY89

M21,22010,18 -19-25MAY89

220  
10  
7

**Q Engine Uses Too Much Fuel**

Check brakes for dragging.

See CTM-5.

Check mower deck spindles for dragging.

Check for correct main jet for elevation. See Parts Catalog for size and elevation.

Check air cleaner for debris.

Test fuel pump output. GO TO **10**

Check fuel tank and lines for leakage.

Check connecting rod to crankshaft bearing clearance and crankshaft to main bearing clearance. See CTM-5.

Check spark plug for fouled condition and check gap: GO TO **11A**

Inspect and adjust throttle cable: GO TO **2**

Inspect and adjust choke: GO TO **3**

Inspect and adjust governor: GO TO **4**

Adjust carburetor idle mixture screw and slow idle: GO TO **6**

Adjust fast idle: GO TO **5**

Inspect carburetor needle valve and seat for wear or damage.

Check carburetor float adjustment.

M21,22010,19 -19-25MAY89

**2 THROTTLE CABLE ADJUSTMENT**

Move throttle lever on dash to fast idle position.

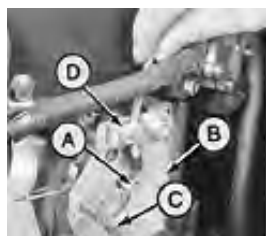

M43659 -UN-12JAN90

Align hole in throttle control lever (A) with hole in control plate (B), install a 15/64 in. drill bit (C) through holes to keep throttle control lever from moving.

Loosen clamp (D) and pull throttle cable tight. Tighten clamp.

Move throttle lever to full choke position.

**CHOKE ROD SHOULD NOT MOVE.**

**IF CHOKE ROD MOVES, GO TO 3**

M21,22010,20 -19-25MAY89

**3 CHOKE ADJUSTMENT**

*NOTE: Adjust throttle cable before adjusting choke linkage.*

Move throttle lever on dash to fast idle position.

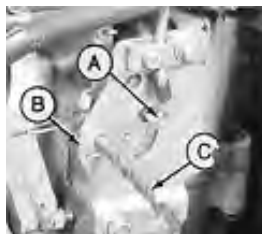

M43660 -UN-12JAN90

**Continued on next page**



## Engine System Diagnosis/Fast Idle Speed Adjustment

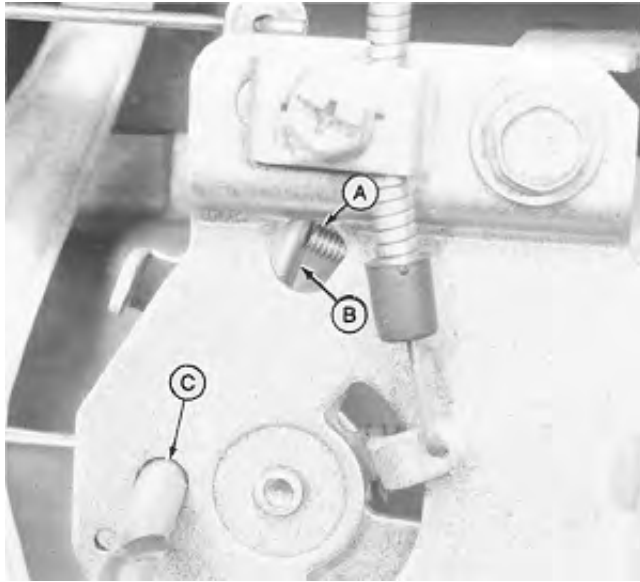

M43661 -UN-09AUG89

Align hole in throttle control lever (A) with hole in control plate (B). Install a 15/64 in. drill bit (C) through holes.

Turn screw (D) counterclockwise until screw does not contact choke control lever (E).

Turn screw clockwise until it just contacts choke control lever.

M21,22010,21 -19-25MAY89

### 4 GOVERNOR ADJUSTMENT

*NOTE: Adjust throttle cable before adjusting governor linkage.*

Move throttle lever on dash to fast idle position.

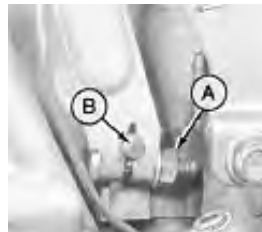

M43662 -UN-12JAN90

Loosen nut (A). Turn governor shaft (B) clockwise until governor shaft stops. Tighten nut.

Move throttle lever to be sure linkage is not binding.

M21,22010,22 -19-25MAY89

### 5 FAST IDLE SPEED ADJUSTMENT

Move transmission control lever to neutral position.

Lock park brake.



M43676 -UN-12JAN90

Start and run engine for 10 minutes.

Move throttle lever on dash to fast idle position.

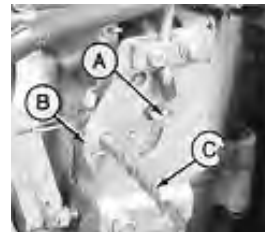

M43660 -UN-12JAN90



**⚠ CAUTION: Engine will be HOT. Be careful not to burn hands.**

Align hole in throttle control lever (A) with hole in control plate (B). Install a 15/64 in. drill bit (C) through holes.

M21,22010,23 -19-25MAY89

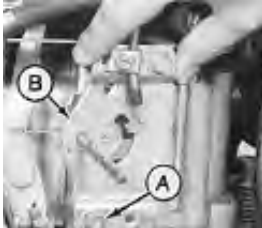
## Engine System Diagnosis/Cylinder Compression Test

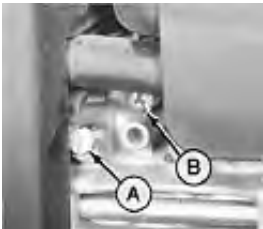
 <p>M43663 -UN-12JAN90</p>	<p>Check engine speed using JDM-71 Vibration Tachometer.</p> <p>Put tachometer (A) on air cleaner. Set tachometer to read 3350 rpm.</p>	 <p>M43664 -UN-12JAN90</p>	<p>Loosen cap screws (A).</p> <p>Move control plate (B) forward or rearward until tachometer reads 3350 ± 100 rpm. Tighten cap screws.</p>	<p><b>AFTER ADJUSTMENT:</b> GO TO ③ to adjust choke.</p> <p>M21,22010,24 -19-25MAY89</p>
---	---	---	--	--

<p><b>⑥ SLOW IDLE SPEED ADJUSTMENT</b></p> <p><b>IMPORTANT: Forcing the idle mixture screw tight will damage the needle and seat.</b></p>	 <p>M43665 -UN-12JAN90</p>	 <p>M43666 -UN-12JAN90</p>	<p>M21,22010,25 -19-25MAY89</p>
---	---	---	---------------------------------

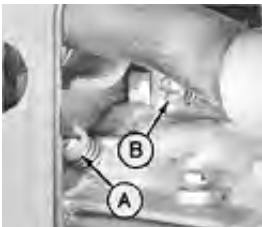
 <p>M43667 -UN-12JAN90</p>	<p>Turn idle mixture screw (A) clockwise until lightly seated, then counterclockwise 1-1/8 turns.</p>	<p>Move transmission control lever to neutral position.</p> <p>Lock park brake.</p>	<p>Start and run engine for 10 minutes.</p> <p>Move throttle lever on dash to slow idle position.</p> <p><b>⚠ CAUTION: Engine will be HOT. Be careful not to burn hands.</b></p> <p>M21,22010,26 -19-25MAY89</p>
--	---	---	--

 <p>M43668 -UN-12JAN90</p>	<p>Check engine speed using JDM-71 Vibration Tachometer.</p> <p>Put tachometer (C) on air cleaner.</p> <p>Turn slow idle stop screw (B) until slow idle speed is 1350 to 1450 rpm.</p>	<p>Turn idle mixture screw in until engine speed drops, then out until engine speed increases and begins to drop again.</p> <p>Adjust idle mixture screw for highest engine speed between drops, then turn screw out an additional 1/4 turn.</p> <p>Turn slow idle stop screw to get idle speed of 1400 ± 100 rpm.</p> <p>M21,22010S,6 -19-21JAN87</p>
---	--	--

<p><b>⑦ CYLINDER COMPRESSION TEST</b></p> <p>Disconnect and ground spark plug wire (A), (An Ignition test plug can be used.)</p> <p><b>IMPORTANT: Spark plug wire must be grounded or electronic</b></p>	<p><b>Ignition could be damaged.</b></p> <p>Remove spark plug and install JDM-59 Compression Gauge (B).</p>	<p style="text-align: right;"><b>Continued on next page</b></p>
--	---	---

220  
10  
10

## Engine System Diagnosis/Oil Pressure Test

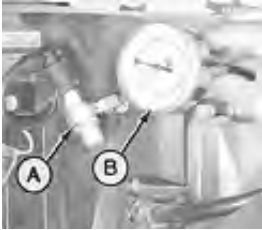
 <p style="font-size: small; margin-top: 5px;">M43669 -UN-31AUG88</p>	<p>Move throttle lever to fast idle position. Lock park brake. Turn key switch to START position.</p> <p><i>LOOK: Record pressure reading.</i></p> <p style="text-align: center;"><b>MINIMUM COMPRESSION</b></p> <table style="width: 100%; border: none;"> <tr> <td style="width: 50%;">160 and 165 . . . . .</td> <td style="width: 50%;">380 kPa (55 psi)</td> </tr> <tr> <td>130, 175, 180, 185 . . . . .</td> <td>483 kPa (71 psi)</td> </tr> </table>	160 and 165 . . . . .	380 kPa (55 psi)	130, 175, 180, 185 . . . . .	483 kPa (71 psi)	<p><b>COMPRESSION LOW: GO TO 7A</b></p> <p>Compression at or near 150 psi: Check valve lash. Then check automatic compression release spring and weights.</p> <p style="font-size: x-small; text-align: right;">M21,22010,27 -19-25MAY89</p>
160 and 165 . . . . .	380 kPa (55 psi)					
130, 175, 180, 185 . . . . .	483 kPa (71 psi)					

<p><b>7A Compression Leak Check</b></p> <p>Remove compression gauge.</p>	 <p style="font-size: x-small; margin-top: 5px;">M43670 -UN-12JAN90</p>	<p>Put clean engine oil on piston rings through spark plug hole.</p> <p>Repeat Step 7</p> <p><b>COMPRESSION PRESSURE INCREASES:</b> Check rings, piston and cylinder bore for broken rings, scoring, wear or damage. Replace as necessary.</p> <p><b>COMPRESSION PRESSURE STILL LOW:</b> Check for leaking intake or exhaust valves, valve seal or cylinder head gasket. Replace as necessary.</p> <p style="font-size: x-small; text-align: right;">M21,22010,28 -19-25MAY89</p>
--	--	---

<p><b>8 CRANKCASE VACUUM TEST</b></p> <p>Remove dipstick.</p> <p>Make test connections from JTO5697 U-Tube Manometer Kit.</p> <p><b>IMPORTANT: Do not open manometer valve until after engine is running or fluid in manometer will be sucked into crankcase while engine is starting.</b></p>	 <p style="font-size: x-small; margin-top: 5px;">M43671 -UN-12JAN90</p>	<p><b>ESSENTIAL TOOLS</b></p> <p>A-8741-F66 Plug B-JTO5703 Barb Fitting C-JTO5699 Line D-JTO5698 U-Tube Manometer</p> <p>Run engine at fast idle.</p> <p>Record crankcase vacuum reading.</p> <p style="text-align: center;"><b>MINIMUM VACUUM</b></p> <table style="width: 100%; border: none;"> <tr> <td style="width: 50%;">130 . . . . .</td> <td style="width: 50%;">7 cm (2.8 in. water)</td> </tr> <tr> <td>160, 165, 175, 180 and 185 . . . . .</td> <td>25 cm (9.8 in. water)</td> </tr> </table> <p>Close manometer valve before shutting off engine.</p> <p><b>IF CRANKCASE VACUUM IS LOW, INSPECT FOR:</b></p> <ul style="list-style-type: none"> <li>Damaged breather.</li> <li>Excessive breather air gap.</li> <li>Leaking fuel pump vacuum line.</li> <li>Damaged dipstick or engine seals.</li> </ul> <p style="font-size: x-small; text-align: right;">M21,22010,29 -19-25MAY89</p>	130 . . . . .	7 cm (2.8 in. water)	160, 165, 175, 180 and 185 . . . . .	25 cm (9.8 in. water)
130 . . . . .	7 cm (2.8 in. water)					
160, 165, 175, 180 and 185 . . . . .	25 cm (9.8 in. water)					

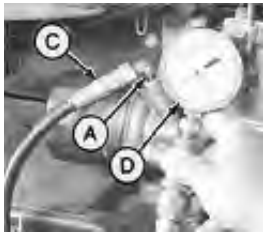
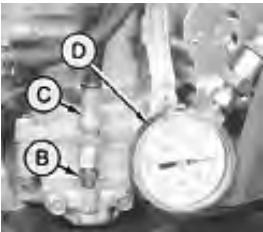
<p><b>9 OIL PRESSURE TEST</b></p> <p><i>NOTE: This test is not used for 130 Tractor.</i></p> <p>Check engine oil level and viscosity.</p>	 <p style="font-size: x-small; margin-top: 5px;">M43672 -UN-12JAN90</p>	<p>On units with an oil filter, disconnect oil pressure sensor wiring lead and remove oil pressure sensor.</p>	 <p style="font-size: x-small; margin-top: 5px;">M43673 -UN-12JAN90</p>	<p>On units without an oil filter, remove pipe plug.</p> <p style="font-size: x-small; text-align: right;">M21,22010,30 -19-25MAY89</p>
---	--	--	---	---

220  
10  
11

*Engine System Diagnosis/Fuel Pump Test*

<p>Make test connections with one of these fittings, hose and gauge.</p> <p>A-JTO3338 90° Elbow Fitting          B-JTO3349 Fitting          C-JTO3017 Hose          D-JTO3344 Gauge, 2000 kPa (300 psi)</p> <p>BLk:</p> <p>Start and run engine for 5 minutes to heat engine oil to normal operating temperature.</p>	<p>Run engine at fast idle.</p> <p>Oil pressure should be at least 240 kPa (35 psi).</p>	<p><b>IF OIL PRESSURE IS LOW, INSPECT FOR:</b></p> <p>Damaged or worn oil pressure relief valve.          Plugged oil pump suction screen.          Loose oil pump cover cap screws.          Damaged or worn oil pump.</p>
---	--	---

M21,22010,31 -19-25MAY89

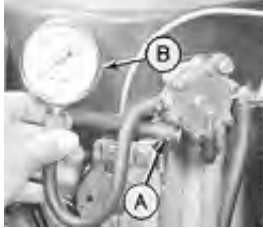
<p><b>10 FUEL PUMP TEST</b></p> <p>Start and run engine at slow idle for 1 minute to fill carburetor with fuel.</p> <p>Stop the engine.</p>	 <p>M43674 -UN-12JAN90</p> <p>Disconnect and plug fuel pump outlet hose (A).</p> <p>Connect JDG356 Pressure Gauge (B) to fuel pump outlet.</p> <p>Start and run engine at fast idle for 15 seconds, then record pressure reading. Stop engine.</p>	<p align="center"><b>MINIMUM PRESSURE</b></p> <p>160 and 165 . . . . . 3.68 kPa (0.5 psi)          130, 175, 180, and 185 . . . . . 6.12 kPa (0.9 psi)</p>
---	--	--

M21,22010,32 -19-25MAY89

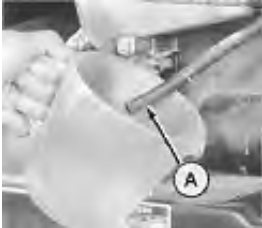
 <p>M43675 -UN-12JAN90</p> <p>Remove fuel pump outlet pressure gauge and connect hose.</p> <p>Disconnect fuel pump outlet hose (A) from carburetor and put it in a graduated container.</p> <p>Start and run engine at fast idle for 15 seconds, then stop the engine. Record container measurement.</p>	<p align="center"><b>MINIMUM FLOW</b></p> <p>130 and 175 . . . . . 80 mL/15 seconds          (2.7 oz/15 seconds)</p> <p>160, 165, 180, and 185 . . . . . 90 mL/15 seconds          (3 oz/15 seconds)</p>	<p><b>IF FUEL PUMP PRESSURE OR FLOW IS LOW, INSPECT FOR:</b></p> <p>Plugged fuel tank vent, fuel lines, or fuel filter.</p> <p>Low crankcase vacuum.</p> <p>Damaged or worn fuel pump.</p>
---	--	--

M21,22010,33 -19-15MAY89

220  
10  
12

*Engine System Diagnosis/Carburetor Cleaning Procedure*

<p><b>11</b> IGNITION SPARK TEST</p>	<p>Engage park brake. Transmission lever in neutral.</p>	 <p>M43603 -UN-31AUG88</p>	<p>Disconnect spark plug wire. Install a spark tester on spark plug wire. Crank engine. Check for spark.</p>	<p>HOT "BLUE" SPARK: GO TO <b>11A</b>  NO SPARK OR "YELLOW" WEAK SPARK: GO TO SECTION 240</p> <p>M21,22010,34 -19-25MAY89</p>
--------------------------------------	--	---	--	---

<p><b>11A</b> Spark Plug Inspection</p> <p>Remove spark plug.</p>	<p>Inspect spark plug for cracked or broken porcelain, worn or eroded electrodes, and excessive carbon or oily deposits.</p> <p><i>NOTE: A normal spark plug will have brown to grayish-tan deposits and slight wear on the electrodes.</i></p>	
---	---	--

 <p>M44166 -UN-08JAN90</p>	<p>Replace plug if worn or damaged.</p> <p>Adjust electrode gap to:</p> <table border="0"> <tr> <td>130, 175,</td> <td></td> </tr> <tr> <td>180, 185</td> <td>..... 0.7-0.8 mm</td> </tr> <tr> <td></td> <td>(0.028-0.031 in.)</td> </tr> <tr> <td>160, 165</td> <td>..... 0.6-0.7 mm</td> </tr> <tr> <td></td> <td>(0.024-0.028 in.)</td> </tr> </table> <p>M21,22010,35 -19-25MAY89</p>	130, 175,		180, 185	..... 0.7-0.8 mm		(0.028-0.031 in.)	160, 165	..... 0.6-0.7 mm		(0.024-0.028 in.)
130, 175,											
180, 185	..... 0.7-0.8 mm										
	(0.028-0.031 in.)										
160, 165	..... 0.6-0.7 mm										
	(0.024-0.028 in.)										

<p><b>12</b> CARBURETOR CLEANING PROCEDURE</p>	<p>Even if machine is new, carburetor may be plugged internally with varnish deposits. Remove, disassemble and clean:</p> <p>Soak carburetor in good carburetor cleaning solvent for 1/2 hour maximum.</p>	<p>Spray all passages with aerosol carburetor cleaning solvent.</p> <p>Rinse carburetor with warm water and dry with compressed air. Make all carburetor adjustments.</p> <p>M21,22010,36 -19-25MAY89</p>
--	--	---

220  
10  
13

220  
10  
14

# Section 240

# ELECTRICAL OPERATION AND TESTS

## Contents

	Page	Page
<b>Group 05—Electrical System Checkout</b>		
Dash Lamp Circuit Check . . . . .	240-05-1	175 tractor (S.N. —475000) . . . . . 240-20-6
Starting Circuit Check (Hydrostatic) . . . . .	240-05-1	175 Tractor (S.N.475001— ) . . . . . 240-20-7
Starting Circuit check (Gear) . . . . .	240-05-1	180 and 185 Tractor
Ignition Spark Check . . . . .	240-05-2	(S.N. —475011) . . . . . 240-20-8
Transmission Neutral Check . . . . .	240-05-2	180 and 185 Tractor (S.N. 475001— ). 240-20-9
PTO Neutral Start Check . . . . .	240-05-2	
Indicator Lamp Running Check . . . . .	240-05-2	
PTO Check . . . . .	240-05-2	
Seat Switch Check for PTO and Ignition .	240-05-3	
Headlight Check . . . . .	240-05-3	
<b>Group 10—Electrical System Diagnosis</b>		
Verify System Grounds . . . . .	240-10-1	
Battery Tests . . . . .	240-10-2	
Dash Lamp Circuit Tests . . . . .	240-10-4	
Starting Circuit Tests . . . . .	240-10-8	
Transmission Neutral Start Switch Test for Gear Tractors . . . . .	240-10-13	
PTO/Safety Switch Test . . . . .	240-10-13	
PTO Circuit Test . . . . .	240-10-13	
Seat Switch Test for PTO Circuit . . . . .	240-10-15	
Seat Switch and Connector Test . . . . .	240-10-15	
Headlight Tests . . . . .	240-10-15	
<b>Group 15—Electrical System Component Tests</b>		
Starter Amp Draw Test . . . . .	240-15-1	
Starter No-Load RPM Test . . . . .	240-15-2	
Starter No-Load Amp Test . . . . .	240-15-3	
Battery Voltage Test . . . . .	240-15-3	
Regulated Output Test . . . . .	240-15-3	
Unregulated Voltage Test . . . . .	240-15-4	
<b>Group 20—Theory of Operation</b>		
Wiring Diagram		
130 Tractor, (S.N. —423869) . . . . .	240-20-2	
130 Tractor (S.N.423870— ) . . . . .	240-20-3	
160 Tractor (S.N. —428430) and 165 tractor (S.N. —425968) . . . . .	240-20-4	
160 Tractor (S.N. 428431— ) and 165 Tractor (S.N. —425969) . . . . .	240-20-5	





## BEFORE YOU START

Always begin with this group to identify a failure in the electrical system. The step-by-step procedures in this group provide you a quick check of the system. No tools are required to perform these checks. If a failure is indicated, you will be referred to a more detailed check, adjustment, or test.

This procedure is designed as a quick check of the system. While performing the check concentrate only on the check you are performing and disregard signals from unrelated components.

Always start with the first step and follow the sequence from left to right. Read each step completely before performing the check.

M21,24005S,1 -19-13OCT86

### 1 DASH LAMP CIRCUIT CHECK

*NOTE: If not equipped with indicator lamps, GO TO 2*

Transmission in neutral.  
PTO OFF.  
Key switch ON.



M43593 -UN-12JAN90

*LOOK: Battery discharge lamp and oil pressure lamp should be ON (if equipped). Low fuel lamp will only come on if fuel level is low.*

**OK: GO TO 3**

**NOT OK: GO TO 1 GROUP 10.**

M21,24005S,2 -19-21JAN87

### 2 STARTING CIRCUIT CHECK FOR HYDROSTATIC TRACTORS

*NOTE: Gear tractors, GO TO 2A*

Sit on seat.



M43596 -UN-12JAN90

Fully depress brake pedal.  
Turn key to START.

*LISTEN: Starter must crank engine. Engine must start (use choke position as needed.)*

**OK: GO TO 3**

**NOT OK: GO TO 2B**

M21,24005S,3 -19-21JAN87

### 2A Starting Circuit Check (Gear Tractors)

Transmission in neutral, brake locked ON.



M43597 -UN-12JAN90

Turn key switch to START.





*LISTEN: Starter must crank engine, engine must start (use choke position as needed.)*

**OK: GO TO 3**



**NOT OK: GO TO 2B**

M21,24005S,4 -19-21JAN87

## Electrical System Checkout/PTO Check

<p><b>2B</b> Ignition Spark Check</p>	<p>Brake pedal locked ON.</p> <p>Open hood, disconnect spark plug wire.</p>	 <p>M43603 -UN-31AUG88</p>	<p>Use a spark tester to determine if engine is firing.</p> <p><i>LOOK: Tester must indicate spark.</i></p>	<p><b>OK:</b> GO TO SECTION 220.</p> <p><b>NOT OK:</b> GO TO <b>2N</b>, GROUP 10.</p> <p>M2,24005S,5 -19-21JAN87</p>
<p><b>3</b> TRANSMISSION NEUTRAL START CHECK</p> <p>Operator on seat.</p>	<p><b>⚠ CAUTION:</b> Be aware that if neutral start circuit is defective, tractor will start and move forward.</p>	 <p>M43594 -UN-12JAN90</p>	<p>Put hydrostatic lever in slow forward or gear selector lever in first gear forward.</p> <p>Turn key switch to START.</p> <p><i>LISTEN: Starter must NOT crank engine.</i></p>	<p><b>OK:</b> GO TO <b>4</b></p> <p><b>NOT OK:</b> GO TO <b>3</b> GROUP 10.</p> <p>M21,24005S,6 -19-21JAN87</p>
<p><b>4</b> PTO NEUTRAL START CHECK</p>	<p><b>⚠ CAUTION:</b> Be aware that if PTO neutral start circuit is defective, tractor will start and PTO will engage.</p>	 <p>M43595 -UN-12JAN90</p>	<p>Turn PTO switch ON.</p> <p>Turn key switch to START.</p> <p><i>LISTEN: Starter must NOT crank engine.</i></p>	<p><b>OK:</b> GO TO <b>5</b></p> <p><b>NOT OK:</b> GO TO <b>4</b> GROUP 10.</p> <p>M21,24005S,7 -19-21JAN87</p>
<p><b>5</b> INDICATOR LAMP RUNNING CHECK</p> <p><i>NOTE: If not equipped with indicator lamps, GO TO <b>6</b></i></p>	<p>Start engine and run at full throttle.</p>	 <p>M43598 -UN-12JAN90</p>	<p><i>LOOK: Battery discharge lamp must be OFF.</i></p> <p>Oil pressure lamp must be OFF.</p>	<p><b>OK:</b> GO TO <b>6</b></p> <p><b>NOT OK:</b> GO TO <b>1</b> GROUP 10.</p> <p>M21,24005S,8 -19-21JAN87</p>
<p><b>6</b> PTO CHECK</p>	<p>Engine OFF. Turn key switch ON.</p>	 <p>M43595 -UN-12JAN90</p>	<p>Turn PTO switch ON.</p> <p><i>LISTEN: PTO must click ON.</i></p>	<p><b>OK:</b> GO TO <b>7</b></p> <p><b>NOT OK:</b> GO TO <b>5</b> GROUP 10.</p> <p>M21,24005S,9 -19-21JAN87</p>

*Electrical System Checkout/Headlight Check*

<p><b>7 SEAT SWITCH CHECK FOR PTO AND IGNITION</b></p>	<p>Sit on seat. Run engine at half throttle.</p>	 <p>M43595 -UN-12JAN90</p>	<p>Turn PTO switch ON. Raise up off seat. <i>LISTEN: Engine must stop.</i></p>	<p><b>OK: GO TO 8</b> <b>NOT OK: GO TO 6</b> GROUP 10.</p> <p>M21,24005S,10 -19-21JAN87</p>
<p><b>8 HEADLIGHT CHECK</b></p>	<p>Key switch ON. Pull light switch out.</p>	 <p>M49133 -UN-20DEC89</p>	<p><i>LOOK: Headlights must be ON.</i></p>	<p><b>OK: GO TO 9</b> <b>NOT OK: GO TO 7</b> GROUP 10.</p> <p>M21,24005S,10A -19-21JAN87</p>
<p><b>8 CHECKOUT PROCEDURE COMPLETE</b></p>	<p>Completing all checks in this procedure indicates that all functions of the electrical system are operating satisfactorily.</p>	<p>If the operator complaint was not identified, the problem may be intermittent. Try to duplicate the conditions of the malfunction as identified by the operator.</p>	<p>Verify the system ground connections and test the battery as instructed in Group 10, then repeat checkout procedure.</p>	<p>IF MALFUNCTION IS NOT IDENTIFIED AFTER REPEATING CHECKOUT PROCEDURE; FACTORY ASSISTANCE IS AVAILABLE THROUGH THE DEALER TECHNICAL ASSISTANCE CENTER (DTAC).</p> <p>M21,24005S,11 -19-21JAN87</p>

*Electrical System Checkout/Headlight Check*

240  
05  
4

## BEFORE YOU START

Always perform the system checkout in Group 05 before making any tests in this group. The step-by-step procedures in this group provide you with the detailed diagnostic information you will need to isolate a malfunction. Basic diagnostic equipment is used. It is assumed that you are familiar with the machine and its electrical components.

As with any electrical system, it is very important that all ground connections are clean and tight and that the battery is fully charged.

Before doing any testing, verify the system ground circuits and test the battery.

Always start with the first step and follow the sequence from left to right. Read each step completely before performing the test.

Upon completing a test or adjustment, check to see whether the problem is corrected by performing the checkout procedure for that step in Group 05.

M21,24010S,1 -19-14OCT86

### VERIFY SYSTEM GROUNDS

Key switch OFF. Open hood.

**IMPORTANT:** Units with S.N. (475001— ) have the ground locations and wiring harness changed. The harness and frame ground connectors are now

located at the battery negative (-) cable to engine connection.

**All components that were grounded to the frame are now grounded internally through wiring harness.**

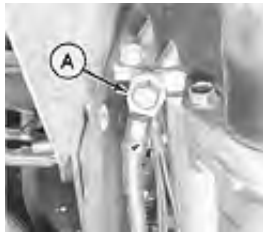

M43700 -UN-12JAN90

Verify the system grounds using a continuity tester or ohmmeter. Check for good continuity between battery negative terminal and the following:

Battery and wiring harness ground connection (A) at right hand side of engine block.

Clean and tighten ground connections as needed before testing battery or performing diagnosis.

*NOTE: Early unit shown.*

**OK: GO TO **A****

M21,24010S,2 -19-14OCT86

Electrical System Diagnosis/Battery Tests

<p><b>A BATTERY TESTS</b></p> <p>If problem is with starting circuit, perform all battery tests. If problem is with other components, perform battery tests only if starter does not crank engine satisfactorily.</p>	<p>Check electrolyte level in each cell or battery. If low add the proper amount of clean soft water.</p>	<p>Check specific gravity of each cell with a hydrometer.</p>	<p><b>SPECIFIC GRAVITY</b></p> <p>All cells less than 1.175: GO TO <b>C</b></p> <p>All cells more than 1.225 with less than 50 points variation: GO TO <b>D</b></p> <p>All cells less than 1.225 with less than 50 points variation: GO TO <b>B</b></p> <p>Variation more than 50 points: REPLACE BATTERY.</p> <p>M21,24010S,3 -19-14OCT86</p>
---	---	---	--

<p><b>B TEST BATTERY VOLTAGE</b></p>	<p>Check battery voltage with voltmeter or JTO5685 Battery Tester.</p>	<p><i>NOTE: Battery need not be disconnected from tractor.</i></p>	<p>12.4 V OR MORE: GO TO <b>F</b></p> <p>LESS THAN 12.4 V: GO TO <b>C</b></p> <p>M21,24010S,4 -19-14OCT86</p>
--------------------------------------	--	--	---

<p><b>C CHARGE BATTERY</b></p>	<p>Connect variable rate charge to battery. Start charger at a slow rate. Increase charge rate one setting at a time. Check ammeter (on charger) after one minute at each setting. Try to maintain a 10-amp charge rate. Use boost setting as necessary.</p> <p>The maximum charging time at boost setting is 10 minutes. Allow an additional 5 minutes for each 10°F below 70°F.</p> <p>If battery did not need water at Step <b>A</b> and is accepting 10-amp charge..GO TO <b>E</b></p> <p>If battery required water at Step <b>A</b> or if all cells were below 1.175 but battery is accepting a 10-amp</p> <p>charge.. GO TO <b>D</b></p> <p>If battery does not accept a 10-amp charge after 10 minutes at boost setting, REPLACE BATTERY.</p> <p>M21,24010S,5 -19-14OCT86</p>	
--------------------------------	--	--

Electrical System Diagnosis/Battery Tests

<p><b>D INCREASE CHARGE RATE</b></p>	<p>Set charger at 15-25 amps.</p>	<p><b>IMPORTANT:</b> Decrease charge rate if battery gases or bubbles excessively or becomes too warm to hold.</p>	<p>Check specific gravity after 30 minutes. (60 minutes for maintenance free battery.)</p>	<p>IF VARIATION BETWEEN CELLS IS MORE THAN 50 POINTS, REPLACE BATTERY.</p> <p>IF VARIATION BETWEEN CELLS IS LESS THAN 50 POINTS, GO TO <b>3</b></p> <p>M21,24010S,6 -19-21JAN87</p>
--------------------------------------	-----------------------------------	--	--	---

<p><b>E CONTINUE CHARGING BATTERY</b></p> <p><b>IMPORTANT:</b> Decrease charge rate if battery gases or bubbles too much or if battery gets too warm to hold.</p>	<p>Continue charging battery until specific gravity is 1.230-1.265 points.</p> <p>IF BATTERY WAS DISCHARGED AT A SLOW RATE (OR DISCHARGE RATE IS UNKNOWN): Charge battery at 10-15 amps for 6-12 hours. (Maintenance free battery may require 12-24 hours.)</p> <p>THEN...GO TO <b>F</b></p>	<p>IF BATTERY WAS DISCHARGED AT A FAST RATE: Charge battery at 20-25 amps. Battery may require 2-4 hours charging time. (Maintenance free battery may need 4-8 hours.)</p> <p>THEN...GO TO <b>F</b></p> <p>M21,24010S,7 -19-21JAN87</p>
---	--	---

Electrical System Diagnosis/Dash Lamp Circuit Tests

<p><b>F</b> LOAD TEST BATTERY</p>	 <p>M36665 -UN-29AUG88</p>	<p>Connect JTO5685 Tester to battery.</p> <p>Follow instruction on back of meter for testing battery.</p>	<p>REPLACE BATTERY AS NEEDED.</p> <p>M21,24010S,8 -19-14OCT86</p>
-----------------------------------	---	---	---

<p><b>1</b> DASH LAMP CIRCUIT TESTS</p>	<p>If any lamp does not operate properly, select the appropriate test as listed at right.</p>	<p>NO LAMPS WORK: GO TO <b>1A</b></p> <p>OIL PRESSURE LAMP TESTS: GO TO <b>1F</b></p> <p>BATTERY DISCHARGE LAMP TESTS: GO TO <b>1U</b></p> <p>LOW FUEL LAMP TESTS: GO TO <b>10</b></p>	<p>GO TO APPROPRIATE TEST: GO TO <b>1D</b></p> <p>M21,24010S,9 -19-14OCT86</p>
---	---	--	--



<p><b>1A</b> No Lamps Work</p>	<p>Open hood. Turn key switch ON.</p>	 <p>M43604 -UN-12JAN90</p>	<p>Check for voltage at yellow wire (A) on key switch.</p>	<p>VOLTAGE: Yellow wire to voltage regulator and dash lamps is open. Run new wires or replace harness.</p> <p>NO VOLTAGE: GO TO <b>1B</b></p> <p>M21,24010S,10 -19-21JAN87</p>
--------------------------------	---------------------------------------	---	--	--

<p><b>1B</b> Main voltage Test at Key Switch</p>	<p>Key switch OFF.</p>	<p>ART NOT FOUND M43604V</p> <p>M43604V -UN-</p>	<p>Check for voltage at single red/blue wire (A) on key switch.</p>	<p>VOLTAGE: Replace key switch.</p> <p>NO VOLTAGE: GO TO <b>1C</b></p> <p>M21,24010S,11 -19-21JAN87</p>
--	------------------------	--	---	---



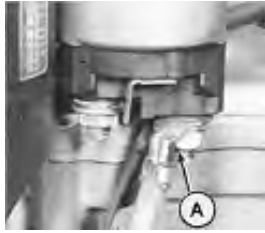

240  
10  
4

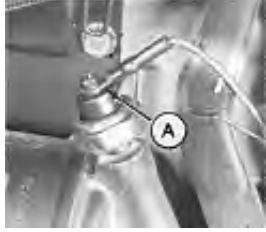
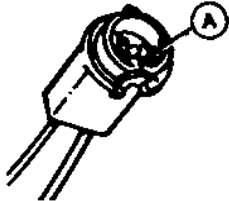

Electrical System Diagnosis/Dash Lamp Circuit Tests

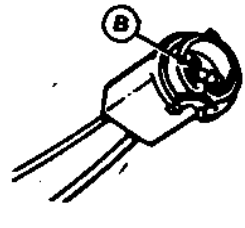

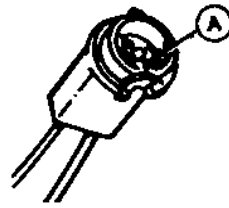
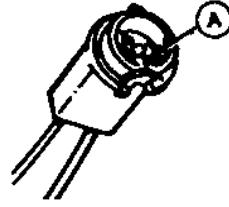



<p><b>1C</b> Voltage Test at Circuit Breaker</p>	<p>Key switch OFF.</p> <p>Remove lower pedestal panel.</p>	 <p>M43606 -UN-12JAN90</p>	<p>Check for voltage at both terminals of circuit breaker (A).</p>	<p>VOLTAGE ONE TERMINAL: Replace breaker.</p> <p>VOLTAGE BOTH TERMINALS: Repair or replace red/blue wire to key switch.</p> <p>NO VOLTAGE; GO TO <b>1D</b></p> <p>M21,24010S,12 -19-21JAN87</p>
<p><b>1D</b> Voltage Test at Solenoid For 160, 165, 175, 180 and 185 Tractors</p> <p>NOTE: For 130 Tractors, GO TO <b>1E</b></p>	<p>Key switch OFF.</p>	 <p>M43607 -UN-12JAN90</p>	<p>Check for voltage at terminal (A) with two red wires.</p>	<p>VOLTAGE: Repair or replace red wire to circuit breaker.</p> <p>NO VOLTAGE: Check battery cables and system ground connection at frame.</p> <p>M21,24010S,13 -19-21JAN87</p>
<p><b>1E</b> Voltage Test at Solenoid for 130 Tractors</p>	<p>Key switch OFF.</p>	 <p>M43650 -UN-12JAN90</p>	<p>Check for voltage at terminal with three red wires (A).</p>	<p>VOLTAGE: Repair or replace red wire to circuit breaker.</p> <p>NO VOLTAGE: Check battery cables and system ground connection at frame.</p> <p>M21,24010S,14 -19-14OCT86</p>
<p><b>1F</b> Oil Pressure Lamp Circuit Test</p> <p>NOTE: If lamp does not go out, GO TO <b>11</b></p>	 <p>M43608 -UN-12JAN90</p>	<p>Disconnect wire (A) from oil pressure switch.</p>	<p>Turn key switch ON.</p> <p>Ground wire lead to engine block.</p> <p>LOOK: Lamp must be ON.</p>	<p>LAMP NOT ON: GO TO <b>1G</b></p> <p>LAMP ON: Replace oil pressure switch.</p> <p>M21,24010S,15 -19-21JAN87</p>
<p><b>1G</b> Oil Pressure Lamp Voltage Test</p>	<p>Open hood. Remove oil pressure lamp socket from dash panel. Check bulb.</p>	 <p>M43653 -UN-26APR89</p>	<p>Turn key switch ON.</p> <p>Check for voltage at terminal (A) with single yellow lead.</p>	<p>VOLTAGE: GO TO <b>1H</b></p> <p>NO VOLTAGE: Yellow wire to key switch is open. Repair or run new wire to key switch.</p> <p>M21,24010S,16 -19-15JAN86</p>

Electrical System Diagnosis/Dash Lamp Circuit Tests

<p><b>1H</b> Oil Pressure Lamp Ground Circuit Test</p> <p>Key switch OFF.</p>	 <p>M43609 -UN-12JAN90</p>	 <p>M43654 -UN-26APR89</p>	<p>Disconnect wire from oil pressure switch.</p> <p>Check continuity of tan wire between lead at switch (A) and lead at bulb socket (B).</p>	<p>NO CONTINUITY: Repair or replace tan wire from bulb socket to oil pressure switch.</p> <p>M21,24010S,17 -19-15OCT86</p>
<p><b>1L</b> Oil Pressure Lamp Short Circuit Test</p>	<p>Key switch OFF.</p>	 <p>M43609 -UN-12JAN90</p>	<p>Check for continuity between tan wire at switch (A) and ground.</p>	<p>CONTINUITY: Tan wire is shorted to ground. Repair or replace.</p> <p>NO CONTINUITY: Check engine oil pressure as instructed in Section 220.</p> <p>M21,24010S,18 -19-15OCT86</p>
<p><b>1J</b> Battery Discharge Lamp Circuit Test</p> <p>NOTE: If lamp does not go off, GO TO <b>1N</b></p>	<p>Key switch OFF.</p> <p>Remove indicator lamp socket from back of dash panel.</p> <p>Remove and check bulb.</p>	 <p>M43653 -UN-26APR89</p>	<p>Check for continuity between terminal with black wire (A) and ground.</p>	<p>CONTINUITY: GO TO <b>1K</b></p> <p>NO CONTINUITY: Black ground wire is open. Repair or run new wire to ground.</p> <p>M21,24010S,19 -19-21JAN87</p>
<p><b>1K</b> Battery Discharge Lamp Voltage Test</p>	<p>Turn key switch ON.</p> <p>Remove indicator lamp socket from dash panel.</p>	 <p>M43653 -UN-26APR89</p>	<p>Check for voltage at socket terminal with orange wire (A).</p>	<p>VOLTAGE: Circuit OK, be sure bulb contacts are aligned for good contact with socket.</p> <p>NO VOLTAGE: GO TO <b>1L</b></p> <p>M21,24010S,20 -19-21JAN87</p>
<p><b>1L</b> Battery Discharge Lamp Voltage Test at Voltage Regulator</p>	<p>Remove lower pedestal shroud.</p>	 <p>M43610 -UN-12JAN90</p>	<p>Turn key switch ON.</p> <p>Check for voltage at orange lead (A) at connector.</p>	<p>VOLTAGE: Repair or replace engine wire to bulb socket.</p> <p>NO VOLTAGE: GO TO <b>1M</b></p> <p>M21,24010S,21 -19-21JAN87</p>
<p><b>1M</b> Battery Discharge Lamp Voltage Test at Voltage Regulator</p>	<p>Key switch ON.</p>	 <p>M43611 -UN-12JAN90</p>	<p>Check for voltage at yellow lead (A) at regulator connector.</p>	<p>VOLTAGE: Verify connector is making good contact, then, replace voltage regulator.</p> <p>NO VOLTAGE: GO TO <b>1A</b></p> <p>M21,24010S,22 -19-15OCT86</p>

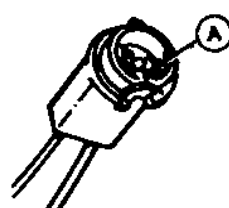
240  
10  
6

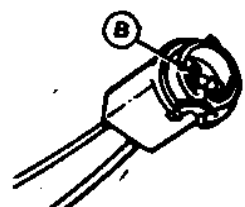
## Electrical System Diagnosis/Dash Lamp Circuit Tests

<p><b>1N</b> <b>Battery Discharge Lamp Operational Test</b></p> <p>For this test, battery voltage must be 12 or less.</p>	<p>Check battery voltage using JTO5685 Battery Tester of voltohmmeter.</p> <p>If voltage is higher than 12.2, use the following procedure to discharge battery.</p>	 <p>M43603 -UN-31AUG88</p>	<p>Use a spark tester to ground spark plug lead.</p> <p>Crank engine for 5-10 seconds.</p> <p>Leave key switch ON.</p>	<p>Check battery voltage to be sure it is less than 12.</p> <p>Crank engine again if needed.</p> <p>M21,24010S,23 -19-15OCT86</p>
 <p>M43997 -UN-09JAN90</p>	<p>Connect spark plug lead.</p>	<p>Run tractor at full throttle.</p>	<p>Battery should reach at least 12.2 volts after several minutes running time.</p>	<p>VOLTAGE COMES UP: Replace regulator.</p> <p>VOLTAGE LOW: Test charging system. GO TO <b>2</b> Group 15.</p> <p>M21,24010S -19-15OCT86</p>
<p><b>1O</b> <b>Low Fuel Lamp Test</b></p> <p>If lamp stays on at all times, be sure fuel tank is at least 1/4 full, then, GO TO <b>1S</b></p>	<p>Low fuel lamp only comes on when fuel tank is near empty. Drain fuel from tank and check operation before testing.</p>	 <p>M43653 -UN-26APR89</p>	<p>Remove lamp socket from dash. Check bulb.</p> <p>Turn key switch ON.</p> <p>Check for voltage at yellow lead (A) at bulb socket.</p>	<p>VOLTAGE: GO TO <b>1O</b></p> <p>NO VOLTAGE: GO TO <b>1F</b></p> <p>M21,24010S,24 -19-21JAN87</p>
<p><b>1P</b> <b>Low Fuel Lamp Circuit Test</b></p>	<p>Remove fender deck.</p> <p>Disconnect 2-pin connector for low fuel sensor.</p> <p>Turn key switch ON.</p>	 <p>M43643 -UN-12JAN90</p>	<p>Connect a jumper wire across terminals of harness side of connector (A).</p> <p><i>LOOK: Indicator lamp ON.</i></p>	<p>LAMP ON: GO TO <b>1R</b></p> <p>LAMP NOT ON: GO TO <b>1O</b></p> <p>M21,24010S,25 -19-21JAN87</p>
<p><b>1O</b> <b>Low Fuel Lamp Ground Circuit Test</b></p>	 <p>M43654 -UN-26APR89</p>	 <p>M43644 -UN-12JAN90</p>	<p>Check continuity between brown wire at a sensor connector (A) and brown wire at bulb socket (B).</p>	<p>CONTINUITY: Verify good ground at black wire of connector.</p> <p>NO CONTINUITY: Repair or replace tan wire from connector to bulb socket.</p> <p>M21,24010S,26 -19-21JAN87</p>



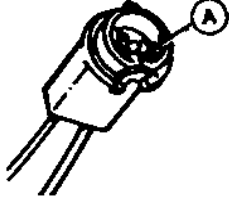

Electrical System Diagnosis/Starting Circuit Tests

<p><b>1R</b> Low Fuel Lamp Sensor Test</p>	<p>Drain all fuel from tank or remove sensor from tank.</p>	 <p>M43644 -UN-12JAN90</p> <p>Connect 2-pin connector (A) and turn key switch ON.</p> <p><i>LOOK: Low fuel lamp must come ON.</i></p>	<p>LAMP ON: Sensor OK. Malfunction may be intermittent. Be sure sensor is pushed down fully in grommet to locate sensor near bottom of tank.</p> <p>LAMP NOT ON: Replace sensor.</p> <p>M21,24010S,27 -19-21JAN87</p>
--	---	--	---





<p><b>1S</b> Low Fuel Lamp Short Circuit Test</p>	<p>Remove indicator lamp socket and bulb from dash panel.</p>	 <p>M43653 -UN-26APR89</p> <p>Key Switch OFF.</p> <p>Check for continuity between terminal with tan wire (A) and ground.</p>	<p>CONTINUITY: Tan wire is shorted to ground. Repair or replace wire.</p> <p>NO CONTINUITY: Check thermistor style sensor for grounded wires or float style sensor for hole in float. Replace sensor as necessary.</p> <p>M21,24010S,28 -19-21JAN87</p>
---	---	--	---

<p><b>2</b> STARTING CIRCUIT TESTS</p> <p>Test battery and verify grounds before testing starting circuit. (See beginning of this group.)</p>	<p>STARTING CIRCUIT MALFUNCTIONS</p> <p>SOLENOID DOES NOT CLICK, STARTER DOES NOT RUN: GO TO <b>2A</b></p> <p>SOLENOID CLICKS BUT STARTER DOES NOT RUN: GO TO <b>2B</b></p>	<p>STARTER RUNS BUT DOES NOT CRANK ENGINE: REPAIR STARTER, SEE CTM-5.</p> <p>STARTER CRANKS ENGINE SATISFACTORILY BUT ENGINE DOES NOT START: GO TO <b>2N</b></p>	<p>GO TO APPROPRIATE TEST.</p> <p>M21,24010S,29 -19-16OCT86</p>
---	---	--	---

Electrical System Diagnosis/Starting Circuit Tests





<p><b>2A</b> Starter Solenoid Test for 160, 165, 175, 180 and 185 Tractors</p> <p>130 Tractors: GO TO <b>2C</b></p>	<p>Put transmission in neutral.</p> <p>Lock brake ON.</p> <p>Open hood.</p> <p>Disconnect and ground spark plug lead.</p>	 <p>M43612 -UN-12JAN90</p>	<p>Disconnect single purple lead from starter.</p> <p>Connect jumper wire to battery terminal and briefly jump across to terminal (A).</p> <p><i>LISTEN: Starter must run.</i></p>	<p>STARTER RUNS: Connect purple wire, then...GO TO <b>2E</b></p> <p>STARTER DOES NOT RUN: GO TO <b>2B</b></p> <p>M21,24010S,30 -19-21JAN87</p>
<p><b>2B</b> Starter Motor Test for 160, 165, 175, 180 and 185 Tractors</p>	<p>Transmission in neutral.</p> <p>Brake ON.</p> <p>Spark plug lead grounded.</p>	 <p>M43645 -UN-12JAN90</p>	<p>Connect a jumper wire and briefly jump across the two large terminals (A).</p> <p><i>LISTEN: Starter should run.</i></p>	<p>STARTER RUNS: Replace solenoid. See CTM-5.</p> <p>STARTER DOES NOT RUN: Check battery cables and connections. Repair or replace starter. See CTM-5.</p> <p>M21,24010S,31 -19-21JAN87</p>
<p><b>2C</b> Starter Solenoid Test For 130 Tractors</p>	<p>Put transmission in neutral. Lock brake ON.</p> <p>Open hood, remove lower pedestal panel.</p> <p>Disconnect and ground spark plug lead.</p>	 <p>M43646 -UN-12JAN90</p>	<p>Disconnect purple/white wire (A) from solenoid. Connect jumper wire and briefly jump across to battery wire.</p> <p><i>LISTEN: Starter must run.</i></p>	<p>STARTER RUNS: Connect purple/white wire, then...GO TO <b>2E</b></p> <p>STARTER DOES NOT RUN: GO TO <b>2D</b></p> <p>M21,24010S,32 -19-02FEB87</p>
<p><b>2D</b> Starter Motor Test For 130 Tractors</p>	<p>Transmission in neutral.</p> <p>Brake locked ON.</p> <p>Spark plug lead grounded.</p>	 <p>M43647 -UN-12JAN90</p>	<p>Briefly jump between the two large red wires (A).</p> <p><i>LISTEN: Starter must run.</i></p>	<p>STARTER RUNS: Replace solenoid.</p> <p>STARTER DOES NOT RUN: Check battery cables and connections, repair or replace starter. See CTM-5.</p> <p>M21,24010S,33 -19-02FEB87</p>

Electrical System Diagnosis/Starting Circuit Tests



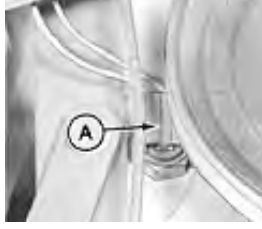

<p><b>2E</b> Voltage Test at Key Switch</p>	<p>Turn key switch ON.</p>	 <p>M43615 -UN-12JAN90</p>	<p>Check for voltage at (A, pink wire) on key switch.</p>	<p>VOLTAGE: GO TO <b>2F</b> NO VOLTAGE: GO TO: <b>2I</b></p> <p>M21,24010S,34 -19-02FEB87</p>
<p><b>2F</b> Starter Circuit Voltage Test at Key Switch</p>	<p>PTO switch OFF. Brakes locked ON. Hold key switch in START position.</p>	 <p>M43616 -UN-12JAN90</p>	<p>Check for voltage at (A, purple wire) on key switch.</p>	<p>VOLTAGE: GO TO <b>2G</b> NO VOLTAGE: Replace key switch.</p> <p>M21,24010S,35 -19-25MAY89</p>
<p><b>2G</b> Starter Circuit Voltage Test at Neutral Start Switch for Hydrostatic Tractors</p> <p>Gear Tractors: GO TO <b>2L</b></p>	<p>Brake OFF. Remove lower pedestal panel. Hold key switch in START position.</p>	 <p>M43613 -UN-12JAN90</p>	<p>Check for voltage at both terminals at neutral start switch (A).</p>	<p>VOLTAGE ONE TERMINAL: GO TO <b>2G</b> VOLTAGE BOTH TERMINALS: Replace neutral start switch. NO VOLTAGE: Purple wire to key switch is open. Repair or replace.</p> <p>M21,24010S,36 -19-21JAN86</p>
<p><b>2H</b> Neutral Start Switch Test</p>	<p>Brake OFF, key switch ON. Depress neutral start switch with brake pedal. Be sure linkage depresses switch fully. Straighten bent linkage as needed.</p>	 <p>M43614 -UN-12JAN90</p>	<p>Check for voltage at both terminals at neutral start switch (A).</p>	<p>VOLTAGE: Purple wire to starter solenoid is open. Repair or replace.</p> <p>M21,24010S,37 -19-20OCT86</p>
<p><b>2I</b> Starter Circuit Voltage Test at PTO Switch.</p>	<p>PTO switch OFF. Turn key switch ON.</p>	 <p>M43617 -UN-12JAN90</p>	<p>Check for voltage at terminal with single pink wire (A) on PTO Switch.</p>	<p>VOLTAGE: Pink wire to key switch is open. Repair or replace. NO VOLTAGE: GO TO <b>2J</b></p> <p>M21,24010S,38 -19-20OCT86</p>

240  
10  
10

Electrical System Diagnosis/Starting Circuit Tests

<p><b>2J</b> Starter Circuit Voltage Test at PTO switch.</p>	<p>PTO switch OFF. Turn key switch ON.</p>	 <p>M43618 -UN-12JAN90</p>	<p>Check for voltage at terminal with double yellow wires (A) at PTO switch.</p>	<p>VOLTAGE: Replace PTO switch. NO VOLTAGE: GO TO <b>2K</b></p> <p>M21,24010S,39 -19-20OCT86</p>
<p><b>2K</b> Starter Circuit Voltage Test at Key Switch.</p>	<p>PTO switch OFF. Turn key switch ON.</p>	 <p>M43604 -UN-12JAN90</p>	<p>Check for voltage at terminal with yellow wire (A).</p>	<p>VOLTAGE: Yellow wire to PTO switch is open. Repair or replace. NO VOLTAGE: GO TO <b>1B</b></p> <p>M21,24010S,40 -19-20OCT86</p>
<p><b>2L</b> Starter Circuit Test at Neutral Start Switch. (Gear Tractors)</p> <p>Transmission in neutral.</p>	<p>Brake locked ON. Remove fender deck. Lift fuel tank off frame. Hold key switch in START position.</p>	 <p>M43627 -UN-12JAN90</p>	<p>Check for voltage at both terminals at neutral start switch (A).</p>	<p>VOLTAGE ONE TERMINAL: GO TO <b>2M</b> VOLTAGE BOTH TERMINALS: Replace purple wire to solenoid. NO VOLTAGE: Purple wire to key switch is open. Repair or replace.</p> <p>M21,24010S,41 -19-21JAN87</p>
<p><b>2M</b> Neutral Start Switch Test</p>	<p>Key switch OFF. Remove connector from neutral start switch.</p>	 <p>M43628 -UN-12JAN90</p>	<p>Check for continuity across terminals (A) of switch. <i>NOTE: Be sure transmission is in neutral.</i></p>	<p>NO CONTINUITY: Replace neutral start switch.</p> <p>M21,24010S,42 -19-21JAN87</p>
<p><b>2N</b> Ignition Spark Test</p>	<p>Lock brake ON. Transmission in neutral.</p>	 <p>M43603 -UN-31AUG88</p>	<p>Use a spark tester to determine if engine is firing. <i>LOOK: Tester must indicate spark.</i></p>	<p>SPARK: GO TO SECTION 220. NO SPARK: GO TO <b>2O</b></p> <p>M21,24010S,43 -19-21OCT86</p>

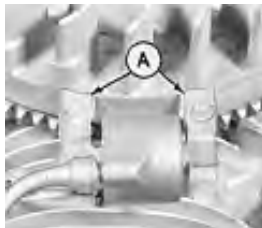
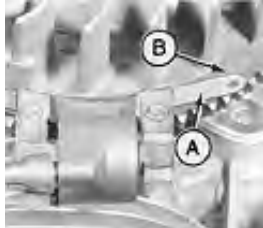



Electrical System Diagnosis/Starting Circuit Tests

<p><b>20</b> Ignition Circuit Grounding Test</p>	<p>Remove lower pedestal panel.</p> <p>Disconnect battery ground cable.</p> <p>Turn key switch ON.</p>	 <p>M43619 -UN-12JAN90</p>	<p>Separate 3-pin engine connector.</p> <p>Check for continuity between terminal with green wire (A) and ground.</p> <p>Repeat test with key switch at START position.</p>	<p>CONTINUITY: Green wire is shorted to ground key switch is defective. Replace as needed.</p> <p>NO CONTINUITY: GO TO <b>2P</b></p> <p>M21,24010S,44 -19-20OCT86</p>
<p><b>2P</b> Ignition Ground Circuit Test</p> <p>Key switch OFF.</p> <p>Separate 3-pin engine connector.</p>	 <p>M43623 -UN-12JAN90</p>	 <p>M43624 -UN-12JAN90</p>	<p>Remove connector from ignitor.</p> <p>Check for continuity of white wire at connectors (A).</p>	<p>CONTINUITY: Replace ignitor and repeat <b>2N</b>. If still no spark: GO TO <b>20</b></p> <p>NO CONTINUITY: Repair or replace white wire from ignitor to 3-pin connector.</p> <p>M21,24010S,45 -19-20OCT87</p>
<p><b>2Q</b> Ignition Coil Air Gap Test</p>	<p>Remove blower housing shroud from engine.</p>	 <p>M43625 -UN-12JAN90</p>	<p>Use a feller gauge to check ignition coil air gap.</p> <p>Check gap under both legs (A) of coil.</p> <p>Air gap must be 0.3 mm (0.12 in.)</p>	<p>AIR GAP OK: GO TO <b>2S</b></p> <p>AIR GAP NOT OK: GO TO <b>2R</b></p> <p>M21,24010S,46 -19-20OCT86</p>
<p><b>2R</b> Ignition Coil Air Gap Adjustment.</p>	 <p>M43626 -UN-12JAN90</p>	<p>Loosen the two coil mounting screws.</p> <p>Place a 0.3 mm (0.12 in.) feeler gauge or length of shim stock (A) against flywheel (B).</p>	<p>Allow magnetic force to draw coil against feeler gauge.</p> <p>Tighten coil mounting screens.</p> <p>Rotate flywheel to remove feeler gauge.</p>	<p>AFTER ADJUSTMENT: Repeat <b>2N</b>. If still no spark, GO TO <b>2S</b></p> <p>M21,24010S,47 -19-20OCT86</p>
<p><b>2T</b> Spark Plug Cap Test</p> <p>Spark Plug cap disconnected.</p>	 <p>M45253 -UN-12JAN90</p>	<p>Measure resistance across spark plug cap terminals.</p> <p>Resistance should be approximately the same as marked on the spark plug cap.</p>		<p>OUT OF SPEC: Replace spark plug cap.</p> <p>M21,24010S,48 -19-21OCT86</p>



240  
10  
12

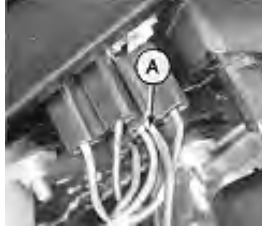

*Electrical System Diagnosis/PTO Circuit Test*

<p><b>3 TRANSMISSION NEUTRAL START SWITCH TEST FOR GEAR TRACTORS</b></p> <p>Hydrostatic tractors GO TO <b>3A</b></p>	<p>Turn key switch OFF.</p> <p>Transmission in neutral.</p> <p>Remove fender deck.</p>	 <p>M43628 -UN-12JAN90</p>	<p>Check for continuity across switch terminals (A). There should be continuity.</p> <p>Put transmission in gear and repeat test. There should be no continuity.</p>	<p><b>BOTH TESTS OK:</b> Adjust transmission linkage, Section 250.</p> <p><b>EITHER OR BOTH TESTS NOT OK:</b> Replace switch.</p> <p>M21,24010S,49 -19-20OCT86</p>
<p><b>3 TRANSMISSION NEUTRAL START SWITCH TEST FOR GEAR TRACTORS</b></p> <p>Hydrostatic tractors GO TO <b>3A</b></p>	<p>Turn key switch OFF.</p> <p>Transmission in neutral.</p> <p>Remove fender deck.</p>	 <p>M43628 -UN-12JAN90</p>	<p>Check for continuity across switch terminals (A). There should be continuity.</p> <p>Put transmission in gear and repeat test. There should be no continuity.</p>	<p><b>BOTH TESTS OK:</b> Adjust transmission linkage, Section 250.</p> <p><b>EITHER OR BOTH TESTS NOT OK:</b> Replace switch.</p> <p>M21,24010S,49 -19-20OCT86</p>
<p><b>3A Transmission Neutral Start Switch Test For Hydrostatic Tractors</b></p>	<p>Turn key switch ON.</p> <p>Transmission in neutral.</p> <p>Remove lower pedestal panel.</p> <p>Brake OFF.</p>	 <p>M43622 -UN-12JAN90</p>	<p>Check for continuity across switch terminals (A). There should be no continuity.</p> <p>Depress switch by hand and repeat test. There should be continuity.</p>	<p><b>BOTH TESTS OK:</b> Switch is OK, check for bent brake linkage. Be sure switch is depressed when brake pedal is fully depressed.</p> <p><b>EITHER TESTS NOT OK:</b> Replace switch.</p> <p>M21,24010S,50 -19-20OCT86</p>
<p><b>4 PTO/SAFETY SWITCH TEST</b></p>	<p>Turn key switch OFF.</p> <p>Turn PTO switch ON.</p>	 <p>M43617 -UN-12JAN90</p>	<p>Check for voltage at terminal with single pink wire (A) on PTO/safety switch.</p>	<p><b>VOLTAGE:</b> Replace PTO/safety switch.</p> <p>M21,24010S,51 -19-20OCT86</p>
<p><b>5 PTO CIRCUIT TEST</b></p>	<p>Turn key switch ON.</p>	 <p>M43618 -UN-12JAN90</p>	<p>Check for voltage at terminal with double yellow lead (A) on PTO/safety switch.</p>	<p><b>VOLTAGE:</b> GO TO <b>5B</b></p> <p><b>NO VOLTAGE:</b> GO TO <b>5A</b></p> <p>M21,24010S,52 -19-21JAN87</p>

*Electrical System Diagnosis/PTO Circuit Test*

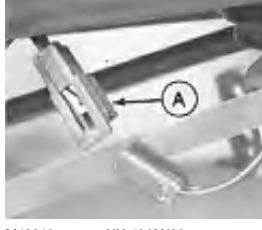
<p><b>5A</b> Key Switch Voltage Test</p>	<p>Key switch ON.</p>	 <p>M43604 -UN-12JAN90</p>	<p>Check for voltage at terminal with single yellow lead (A) on key switch.</p>	<p>VOLTAGE: Yellow wire to PTO/safety switch, voltage regulator, or dash lamps is open. Run new wire to replace harness.</p> <p>NO VOLTAGE: GO TO <b>1B</b></p> <p>M21,24010S,53 -19-21JAN87</p>
<p><b>5B</b> PTO/Safety Switch Test</p>	<p>Key switch ON.</p>	 <p>M43620 -UN-12JAN90</p>	<p>Check for voltage at terminal with single blue lead (A) on PTO/safety switch.</p>	<p>VOLTAGE: GO TO <b>5C</b></p> <p>NO VOLTAGE: Replace PTO/safety switch.</p> <p>M21,24010S,54 -19-21JAN87</p>
<p><b>5C</b> PTO Clutch Circuit Test</p>	<p>Separate 2-pin connector for PTO clutch. Connector is located under right side of frame just below engine oil drain plug.</p>	 <p>M43649 -UN-12JAN90</p>	<p>Turn key switch ON.</p> <p>Check for voltage across leads of connector (A).</p>	<p>VOLTAGE: Repair PTO clutch. See Section 40.</p> <p>NO VOLTAGE: GO TO <b>5D</b></p> <p>M21,24010S,55 -19-21JAN87</p>
<p><b>5D</b> PTO Clutch Ground Circuit Test</p>	<p>Turn key switch OFF.</p>	 <p>M43649 -UN-12JAN90</p>	<p>Check for good continuity between connector terminal (A) with black lead and ground.</p>	<p>GOOD GROUND: Blue wire from clutch connector to switch is open. Repair or replace.</p> <p>NO GROUND: Check system grounds, run new ground wire as needed.</p> <p>M21,24010S,56 -19-21JAN87</p>

**6 SEAT SWITCH TEST FOR PTO CIRCUIT**

Turn key switch OFF.  
Separate seat switch connector.



M43621 -UN-12JAN90

With operator off seat, check continuity across connector terminals (A). There should be continuity.

Press on seat switch and repeat test. There should be NO continuity.

**OK:** Gray wire to PTO/safety switch is open or grounded or green wire from PTO/safety to key switch is grounded.

**NOT OK:** GO TO **6A**

M21,24010S,57 -19-20OCT86

**6A SEAT SWITCH AND CONNECTOR TEST**



M49261 -UN-20DEC89

Key switch off.  
Operator off seat.

Be sure seat switch and connector are fastened securely.

Check continuity across connector terminals (A). There should be continuity.

Press on seat switch and repeat test. There should not be continuity.

**OK:** Seat switch and connector OK.

**NOT OK:** Continue with test.

M21,24010S,58 -19-20JAN86



M49260 -UN-20DEC89

Separate seat switch from connector.  
Check continuity across seat switch terminals (A). There should be continuity.  
Press on seat switch and repeat test. There should not be continuity.

**OK:** Seat switch OK; connector is defective, replace connector.

**NOT OK:** Replace seat switch.

M21,24010S,59 -19-20JAN86



M49139 -UN-20DEC89

Check for voltage at yellow wire on light switch.

Test for continuity across light switch terminals.

**VOLTAGE/CONTINUITY:** Replace YELLOW/GREEN wire to light sockets.

**VOLTAGE/NO CONTINUITY:** Replace light switch.

**NO VOLTAGE:** GO TO

M21,24010S,58A -19-02FEB87

*Electrical System Diagnosis/Headlight Tests*

	<p>Check for voltage at yellow wire on light switch.</p> <p>Test for continuity across light switch terminals.</p>	<p>VOLTAGE/CONTINUITY: Replace YELLOW/GREEN wire to light sockets.</p> <p>VOLTAGE/NO CONTINUITY: Replace light switch.</p> <p>NO VOLTAGE: GO TO</p>
<p>M49139 -UN-20DEC89</p>		<p>M21,24010S,58A -19-02FEB87</p>

<p><b>7A Power Circuit Tests for Lighting</b></p> <p>Separate fuse holder.</p> <p>Turn keyswitch OFF.</p>	<p>Test for continuity of yellow wire between fuse holder and light switch.</p>	<p>Test for continuity of yellow wire between accessory connector and fuse block.</p>	<p>Test for continuity of terminal at PTO switch with double yellow wires and accessory connector.</p>	<p>CONTINUITY: Wire is OK.</p> <p>NO CONTINUITY: Repair or replace wire(s) as necessary.</p>
				<p>M21,24010S,59 -19-02FEB87</p>

# Group 15 Electrical System Component Tests

## 1 STARTER AMP DRAW TEST

Before performing starter amp draw test, verify system ground connections and test battery. (See information at beginning of Group 10.)

Disconnect spark plug lead.



Use a spark tester (A) to ground lead to engine.

M43603 -UN-31AUG88

M21,24015S,1 -19-21OCT86



M43696 -UN-12JAN90

**IMPORTANT: Before making any test connections, turn load knob (A) on meter fully counterclockwise.**

Connect JTO5685 Battery Tester to tractor battery: Red lead to positive terminal, black lead to negative terminal.

Crank engine with starter and read voltage on meter while cranking.

Check engine rpm while cranking. Use JTO28201 or JTO1638 Photo Tachometer.

With key off, adjust load knob (A) until battery voltage reads the same as when cranking.

Read amperage on meter. Meter should read 150 amps or less.

Turn load knob fully counterclockwise.

150 AMPS OR LESS BUT RPM IS LOW: GO TO **1B**

150 AMPS OR LESS AT ABOUT 300 RPM: Starter OK, check engine oil viscosity and internal components (CTM-5).

150 AMPS OR MORE: GO TO **1A**

M21,24015S,2 -19-21JAN87

Electrical System Component Tests/Starter No-Load RPM Test

**1A** Starter No-Load RPM Test for 160, 165, 175, 180 and 185 Tractors

130 Tractors GO TO **1B**

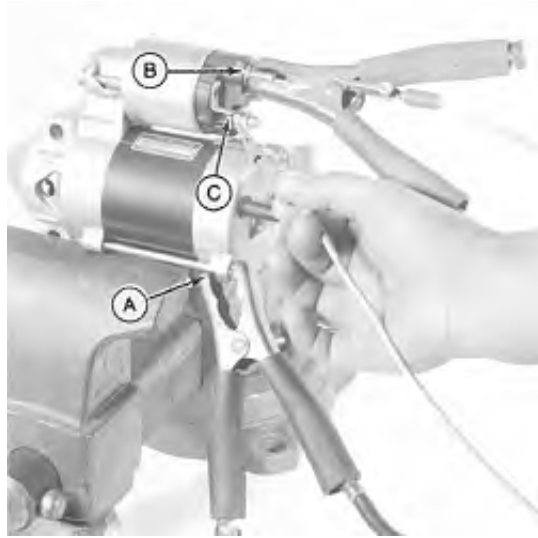

M43697 -UN-12JAN90

Put starter in a vise.

Connect jumper cables to tractor battery or one of similar capacity.

Connect negative cable (A) to starter body.

Connect positive cable (B) to solenoid terminal.

Use a jumper wire to jump from positive cable to solenoid terminal (C).

Measure starter rpm with a photo tachometer.

RPM should be at least 6000.

RPM 6000 OR MORE: GO TO **1C**

RPM LESS THAN 6000: Be sure battery is of proper size and is fully charged. Repeat test as needed with fully charged battery. If rpm is still below spec., disassemble, inspect and repair starter as instructed in CTM-5.

M21,24015S,3 -19-21JAN87

**1B** Starter No-Load RPM Test For 130 Tractors



M37203 -UN-25JAN90

Put starter in a vise.

Connect jumper cables to tractor battery or one of similar capacity.

Connect positive lead (A) to starter positive terminal.

Connect negative cable (B) to starter body.

Use photo-tachometer (C) or mechanical hand tachometer to measure starter rpm.

RPM should be at least 7000.

RPM 7000 OR MORE: GO TO **1C**

RPM LESS THAN 7000: Be sure battery is of proper size and is fully charged. Repeat test as needed with fully charged battery. If rpm is still below spec., disassemble, inspect and repair starter as instructed in CTM-5.

M21,24015S,4 -19-21OCT86

Electrical System Component Tests/Regulated Output Test

**1C** Starter No-Load Amperage Test For All Tractors



M43698 -UN-12JAN90

Put starter in a vise as instructed in Steps 1A or 1B.

With starter running, check amperage with JTO5712 Current Gun (A).

**AMPERAGE SPECIFICATION**

130 Tractors-60 amps or less.

160, 165, 175, 180 and 185 Tractors-50 amps or less.

(130 starter shown)

**AMPERAGE IN SPEC:** Starter OK. Check oil viscosity or internal engine components. See CTM-5.

**AMPERAGE OUT OF SPEC:** Check for binding or seizing bearings, sticking brushes, dirty or worn commutator. See CTM-5.

M21,24015S,5 -19-21JAN87

**2** BATTERY VOLTAGE TEST FOR CHARGING SYSTEM



M43696 -UN-12JAN90

**IMPORTANT: Before making any test connections, turn load knob (A) fully out (counterclockwise.)**

Connect JTO5685 Battery Tester to tractor battery.

Run engine at fast idles.

Battery voltage should be greater than 12.2 but less than 15.

IN SPEC: GO TO **2A**

VOLTAGE GOES ABOVE 15: Replace voltage regulator.

VOLTAGE BELOW 12.5: GO TO **2A**

M21,24015S,6 -19-21JAN86

**2A** Regulated Output Test

**IMPORTANT: Perform this test quickly to prevent damage to battery tester. DO NOT apply full load to battery for more than 5-10 seconds.**



M43696 -UN-12JAN90

Turn load knob (A) fully out (counterclockwise). Connect JTO5685 Battery Tester to battery.

Run engine at full throttle.

Turn load knob (A) in until maximum voltage and amperage output is obtained.

**CHARGING SYSTEM SPECS:** 160, 165, 175, 180 AND 185-12.2-13.8 V at 14 amps minimum. 130 and 12.2-13.8 V at 12 amps minimum.

Continued on next page

Electrical System Component Tests/Unregulated Voltage Test

IN SPEC: Charging system is normal.

OUT OF SPEC: GO TO 2B

MO;M21,24015S,8 19 21JAN87 D

2B Unregulated Voltage Output Test



M43699 -UN-12JAN90

Run engine at full throttle. Disconnect 3-pin connector (a) at right side of engine.

Set voltmeter to 50 or 100 volts AC.

Connect meter across terminals with black wires.

Meter should read about 34 volts minimum.

34 VOLTS OR MORE: Stator OK.

LESS THAN 34 VOLTS: Replace stator as instructed in CTM-5.

M21,24015S,7 -19-21JAN86

3 VOLTAGE REGULATOR LEAKAGE TEST



M49244 -UN-20DEC89

Remove 10 amp fuse.

Set up multimeter to read milliamps.

Install red meter lead in fuse block connector to battery (a).

Install black meter lead in fuse block connector to reg/rect. (B).

Meter should have a maximum reading of 50 milliamps.

50 MILLIAMPS OR LESS-REGULATOR OK.

MORE THAN 30 MILLIAMPS-REPLACE REGULATOR.

M21,24015S,9 -19-21JAN87



**ABOUT THIS GROUP**

This group contains the wiring diagrams for all tractor models. This diagrams are printed on three-page foldouts which allow you to fold the diagram out while working in the diagnostic sections of the Technical Manual.

M21,24020S,1 -19-21OCT86



Theory of Operation

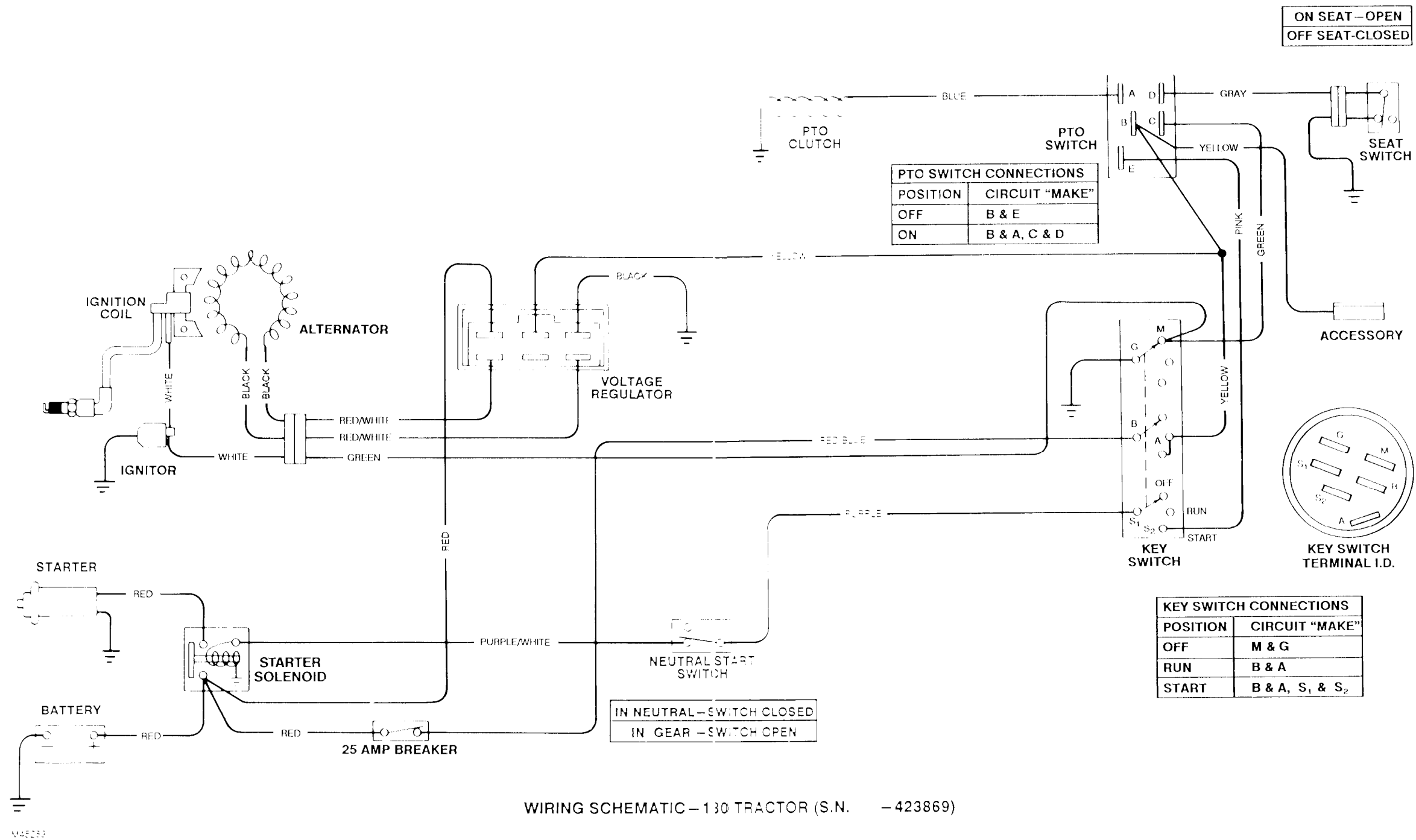

WIRING SCHEMATIC - 130 TRACTOR (S.N. - 423869)

Theory of Operation

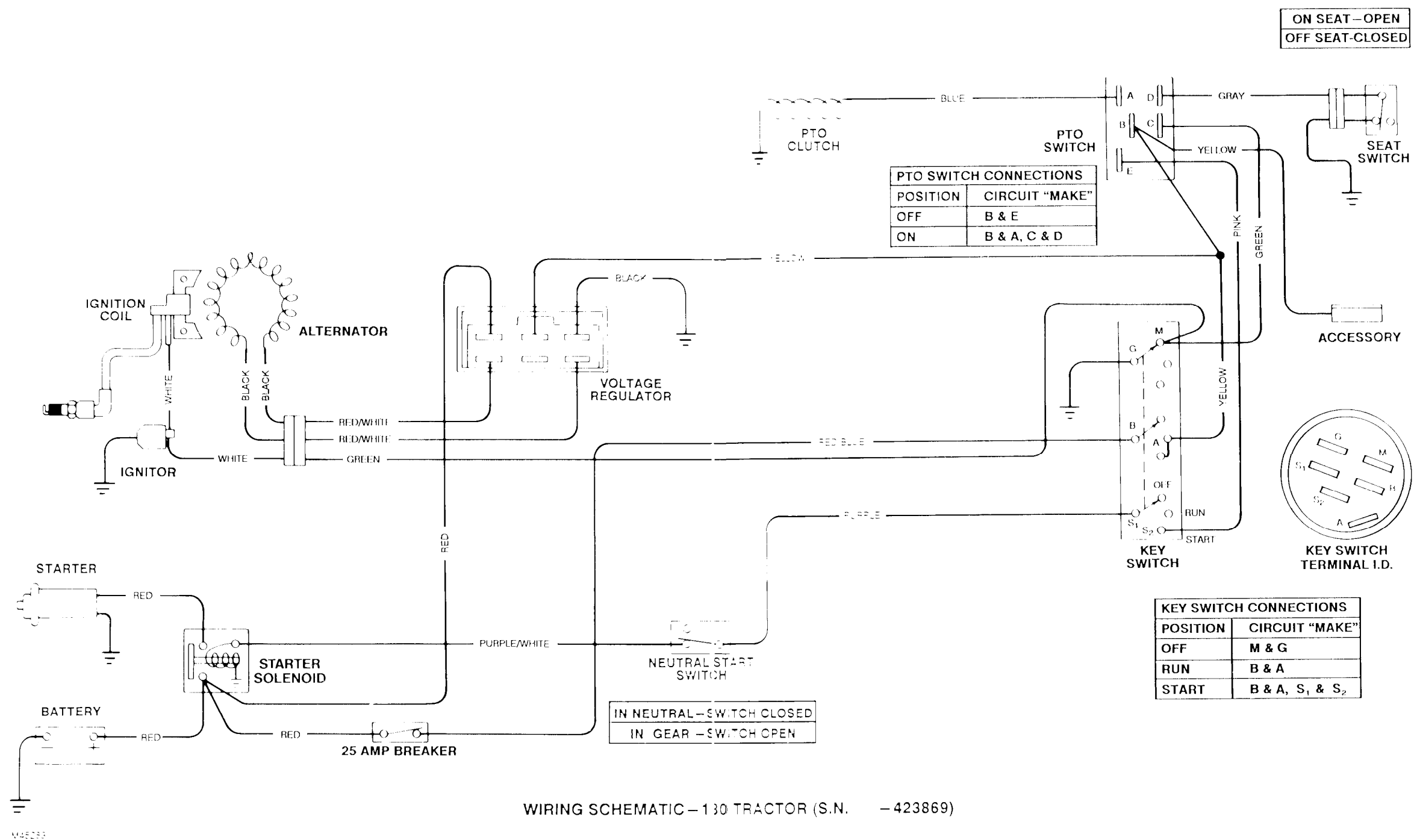

WIRING SCHEMATIC - 130 TRACTOR (S.N. - 423869)

Theory of Operation

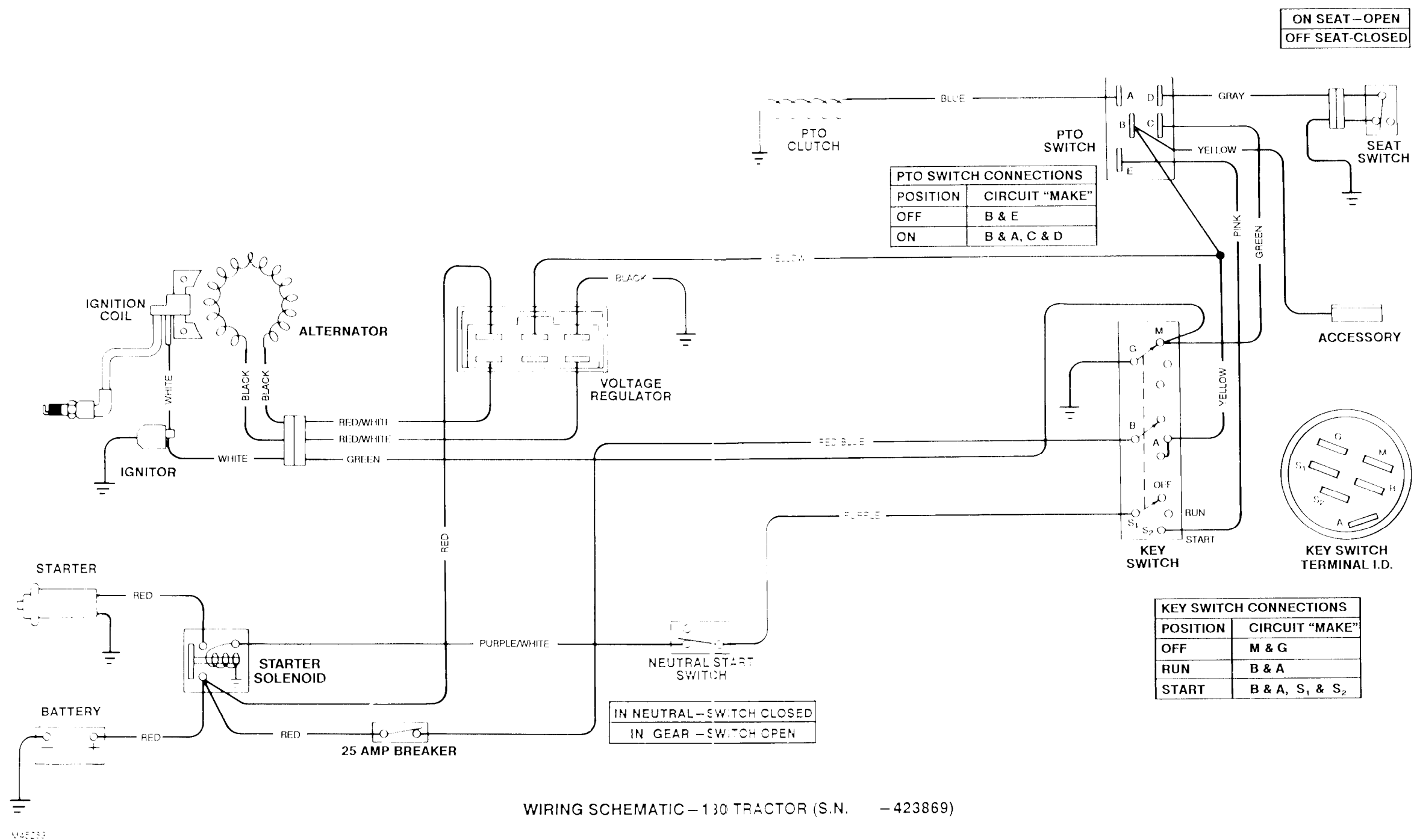

WIRING SCHEMATIC - 130 TRACTOR (S.N. - 423869)



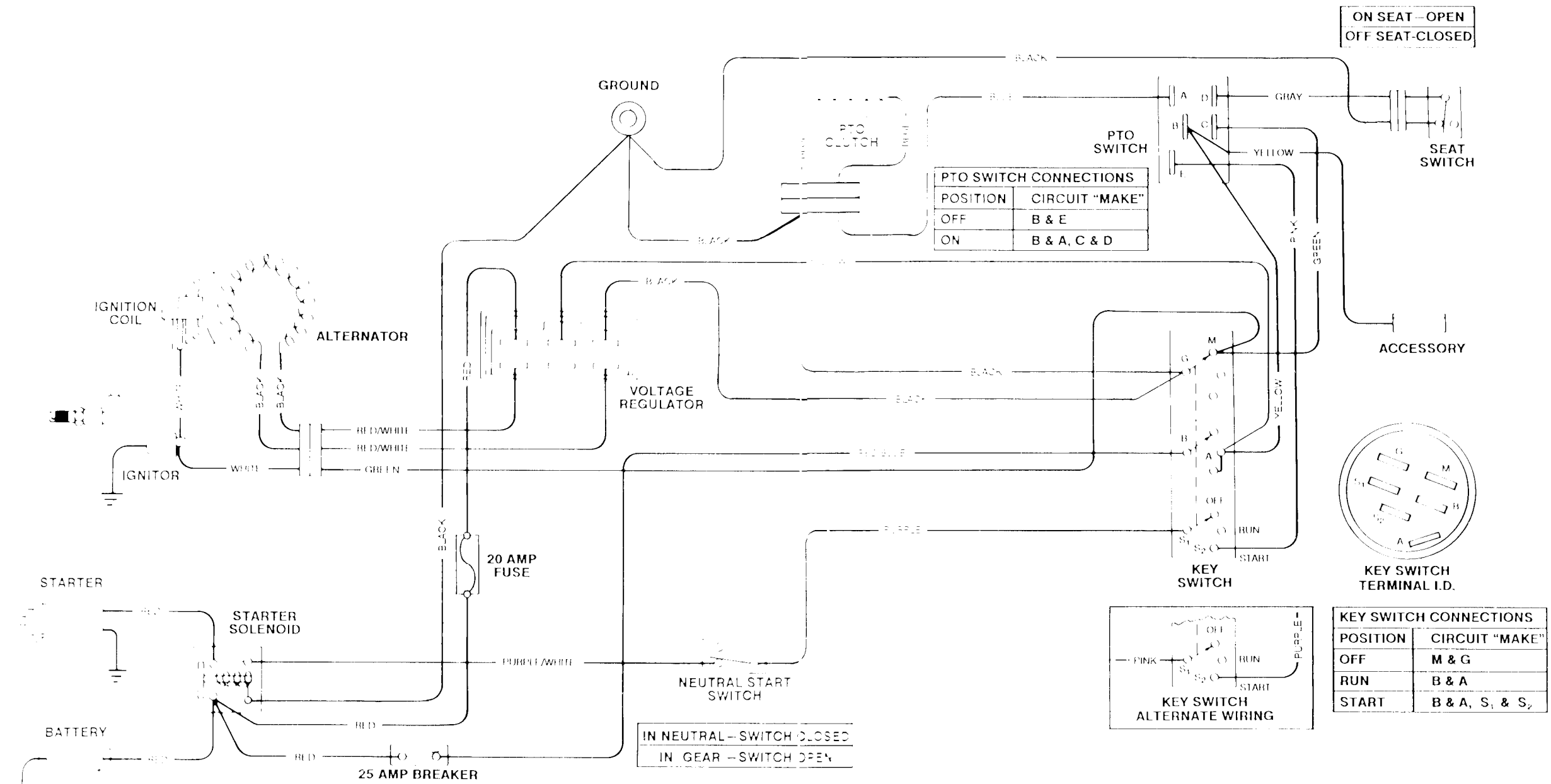

WIRING SCHEMATIC - 130 TRACTOR (S.N. 423870 - )

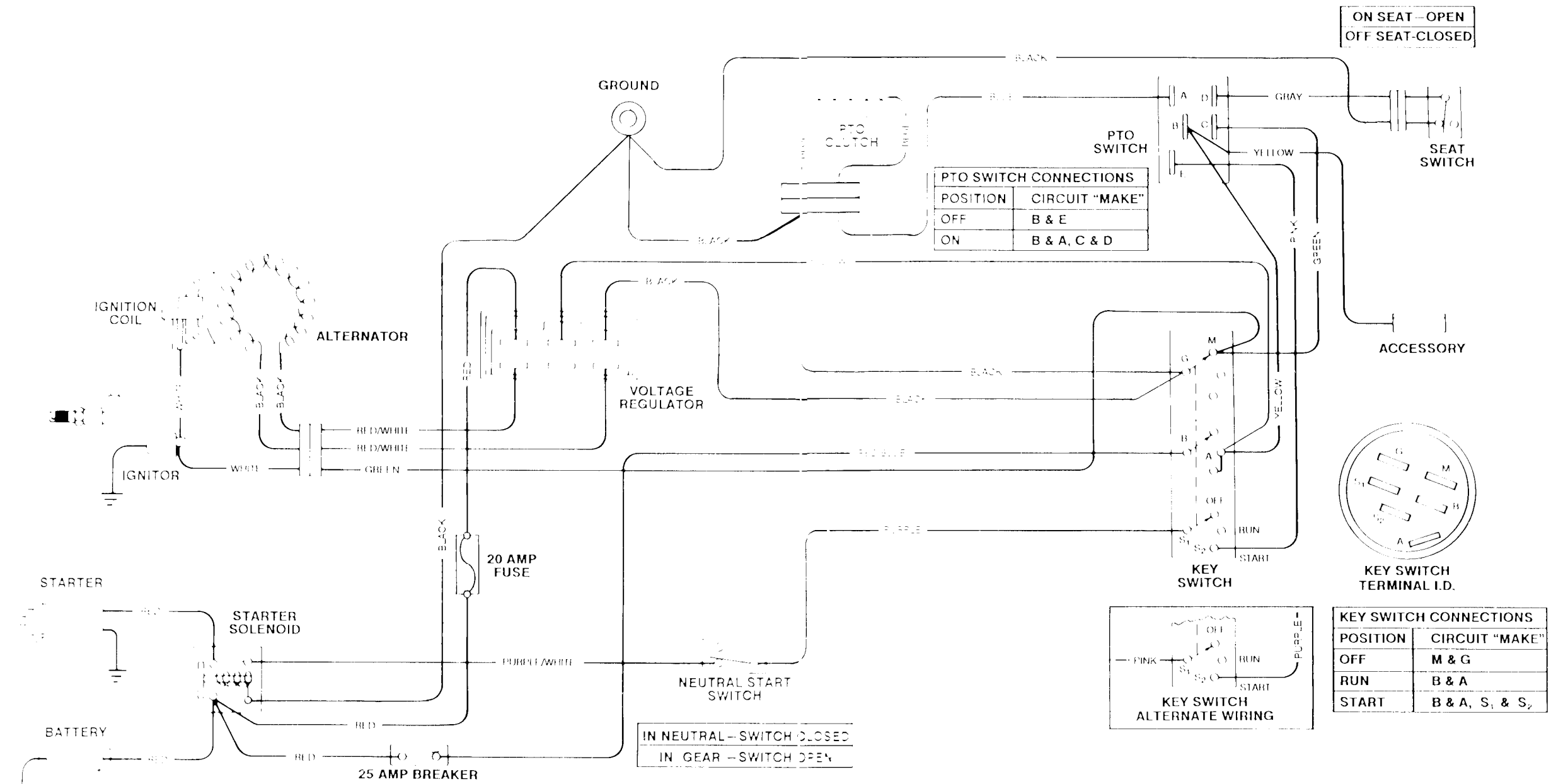

WIRING SCHEMATIC - 130 TRACTOR (S.N. 423870 - )



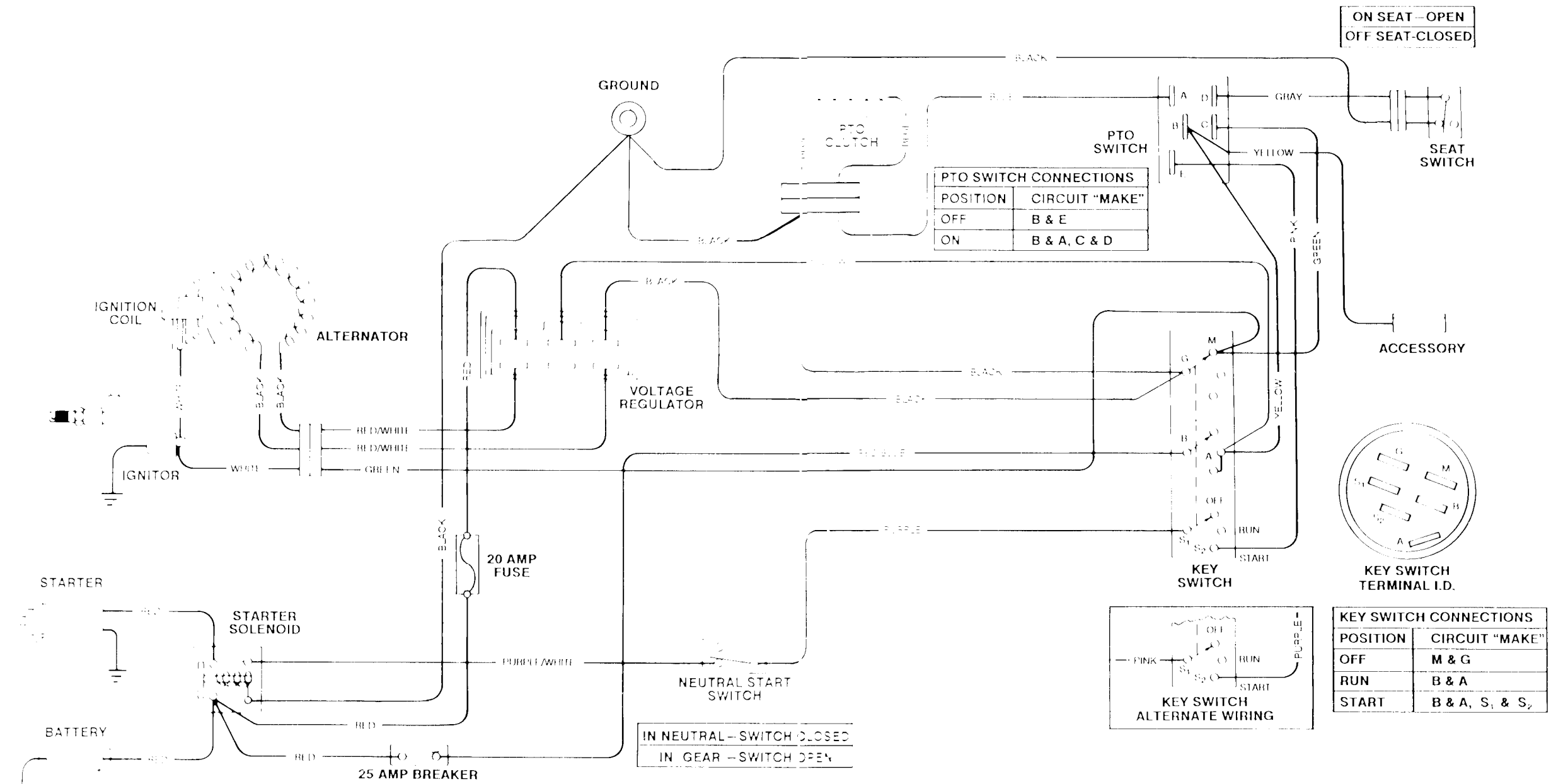

WIRING SCHEMATIC - 130 TRACTOR (S.N. 423870 - )



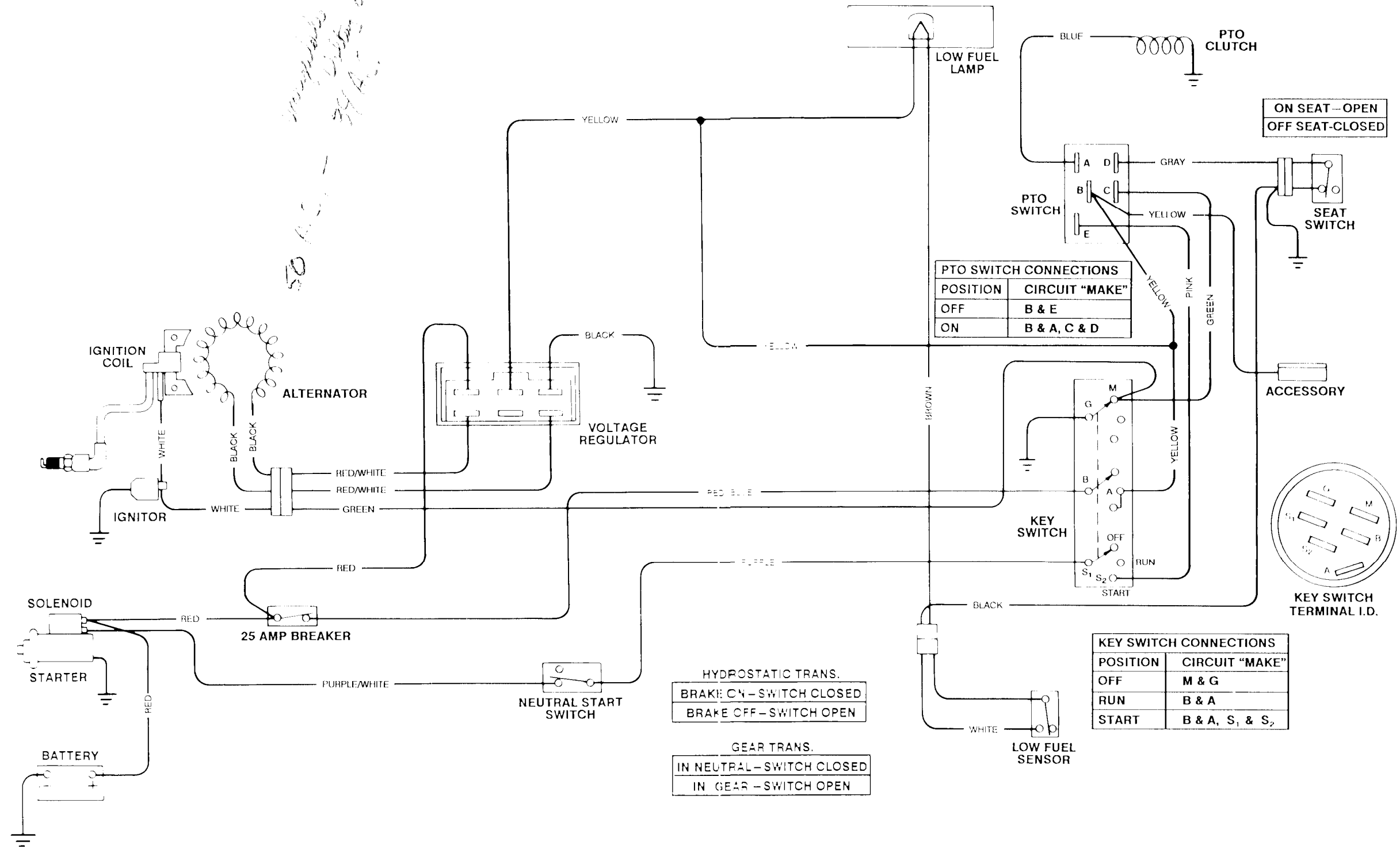

WIRING SCHEMATIC - 160 TRACTOR (S.N. -428430)  
 165 TRACTOR (S.N. -425968)

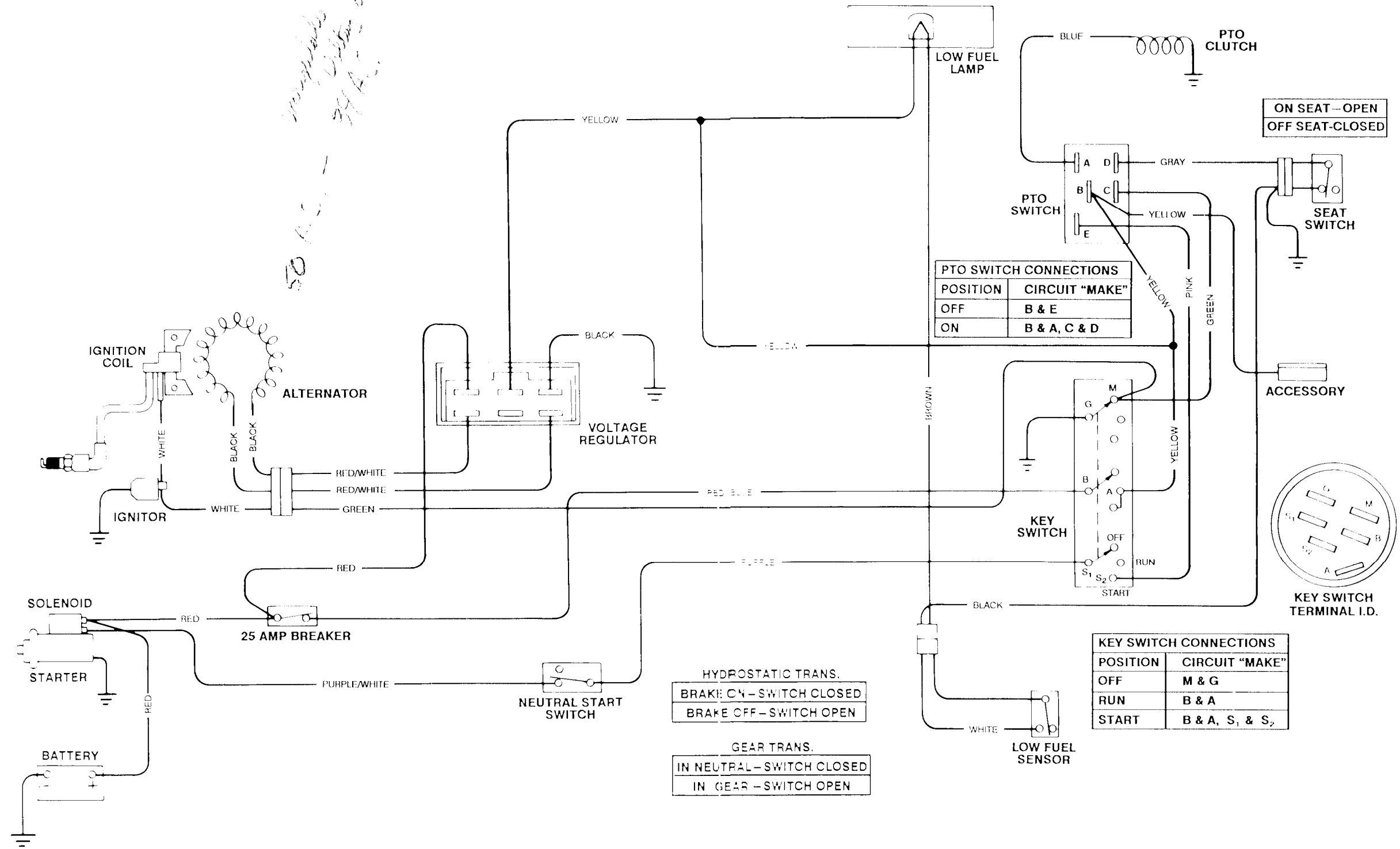

WIRING SCHEMATIC - 160 TRACTOR (S.N. -428430)  
 165 TRACTOR (S.N. -425968)

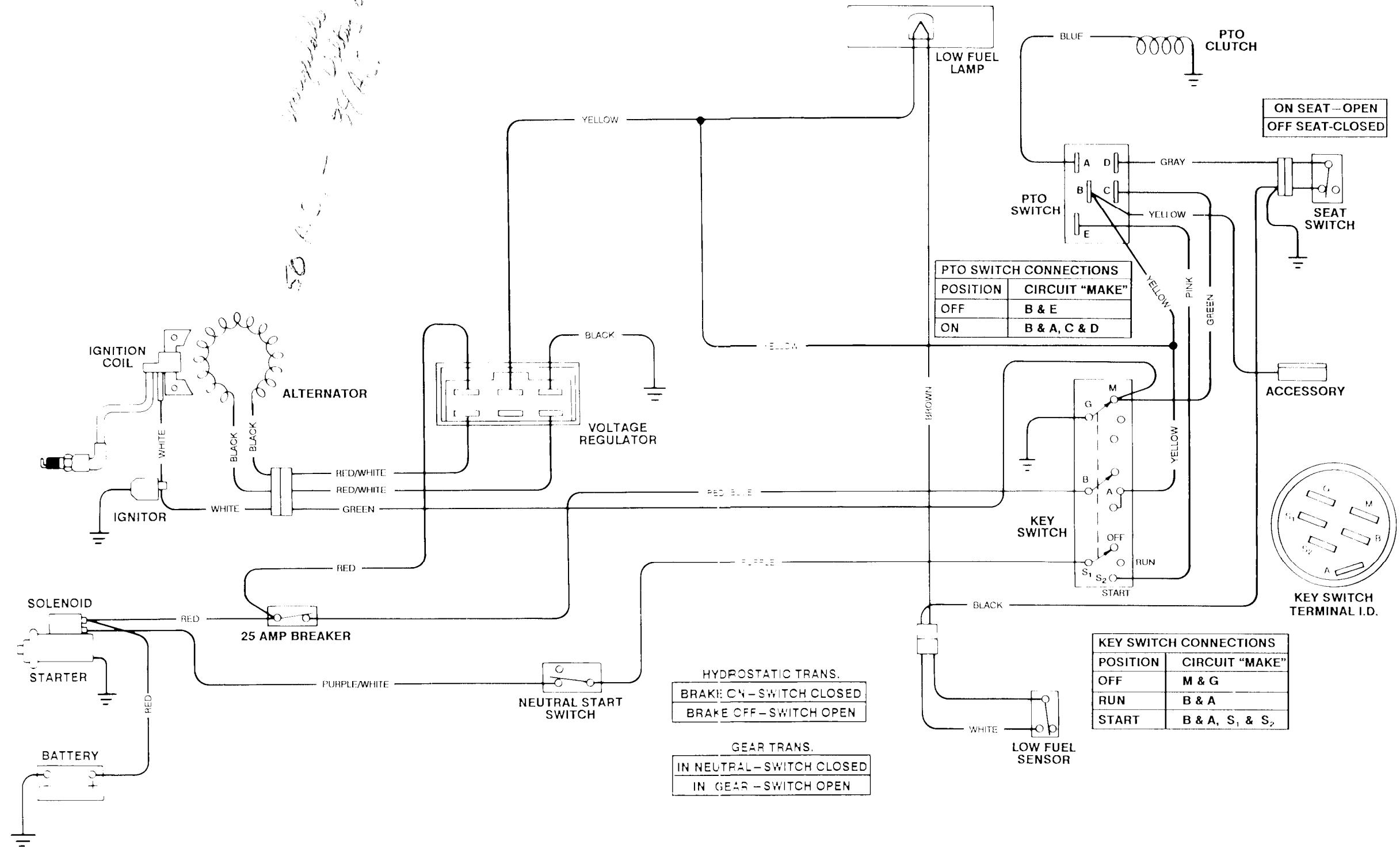

WIRING SCHEMATIC - 160 TRACTOR (S.N. -428430)  
 165 TRACTOR (S.N. -425968)



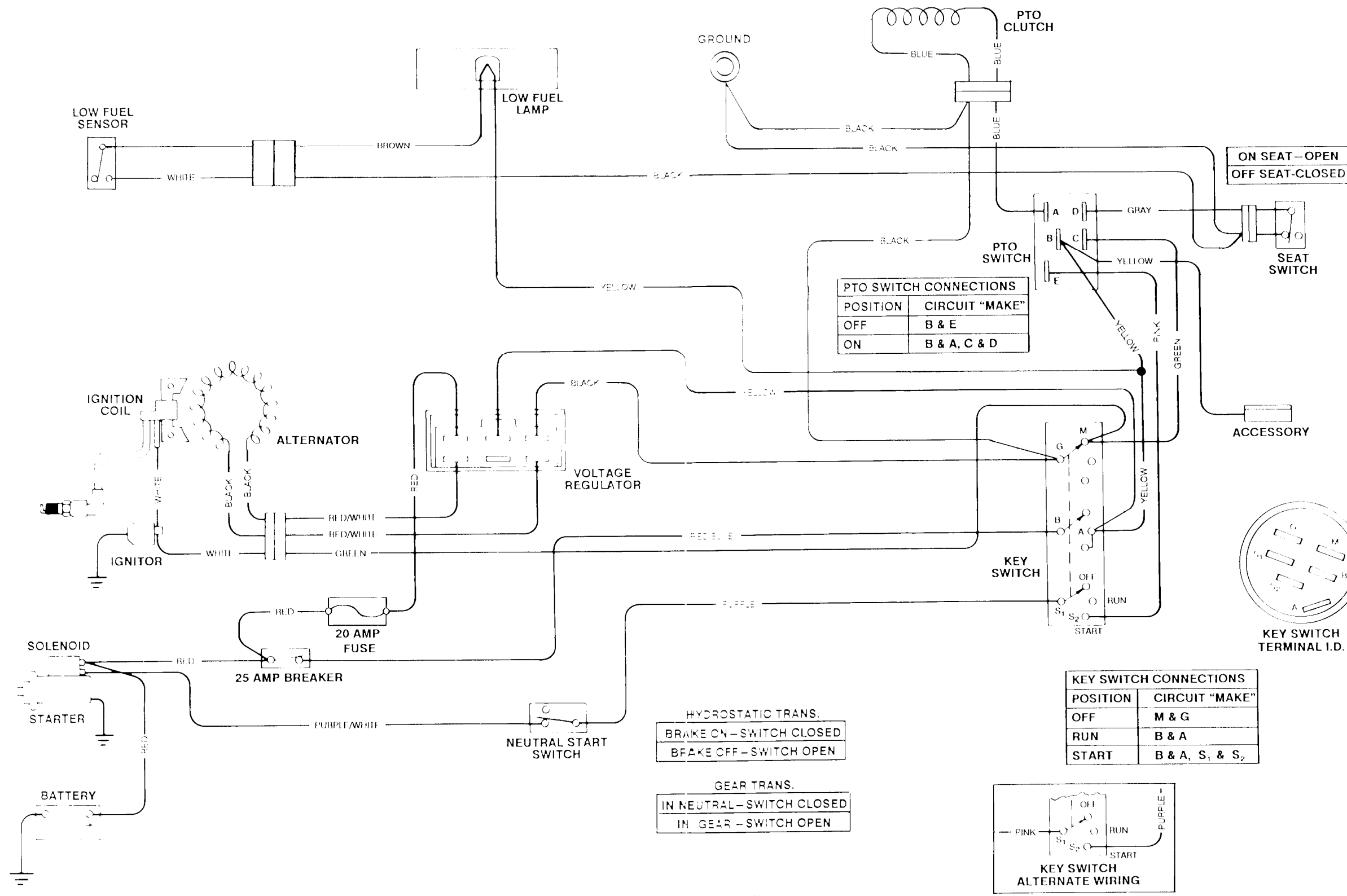

WIRING SCHEMATIC - 160 TRACTOR (S.N. 428431 - )  
 165 TRACTOR (S.N. 425969 - )

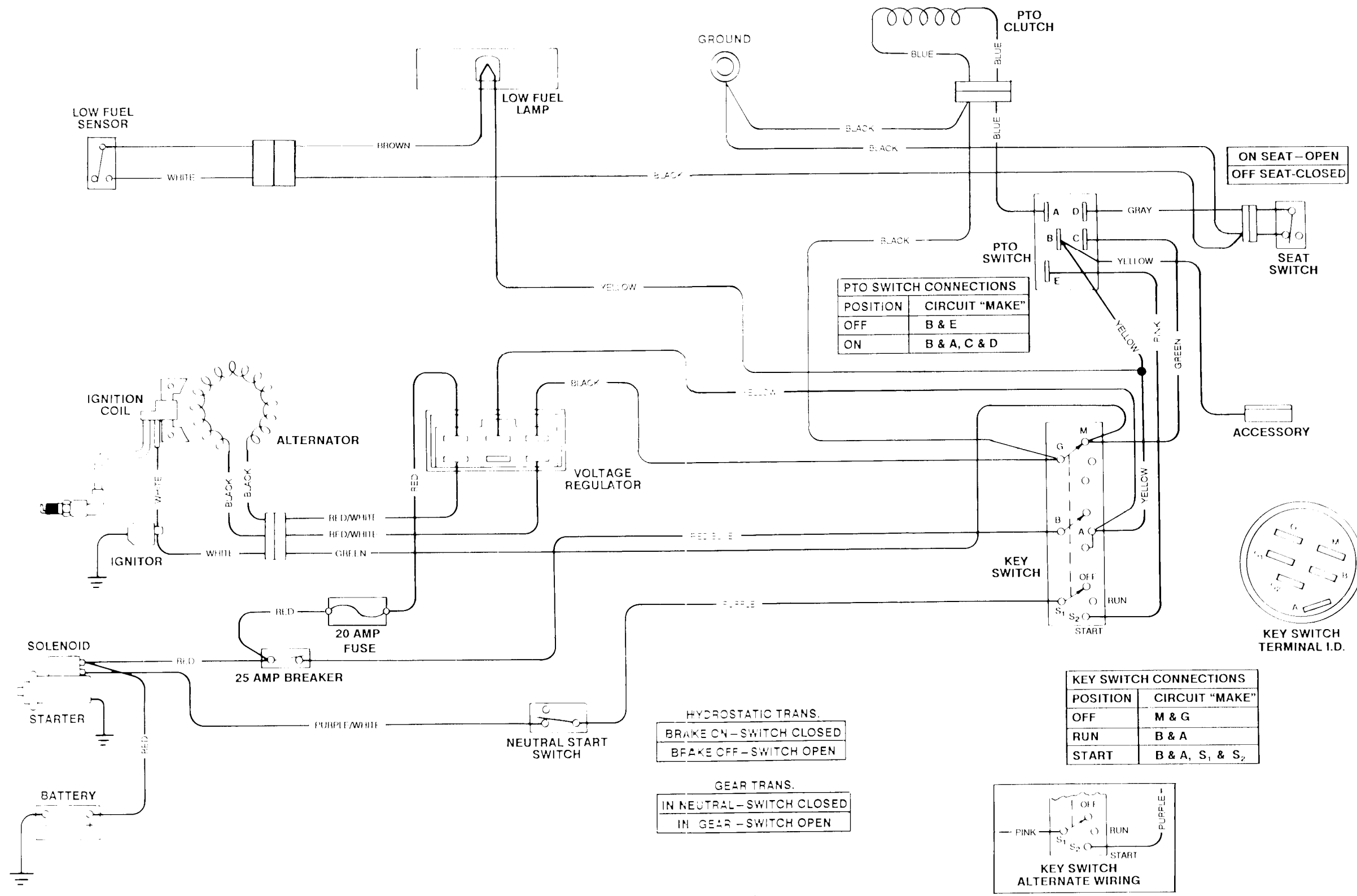

WIRING SCHEMATIC - 160 TRACTOR (S.N. 428431 - )  
 165 TRACTOR (S.N. 425969 - )



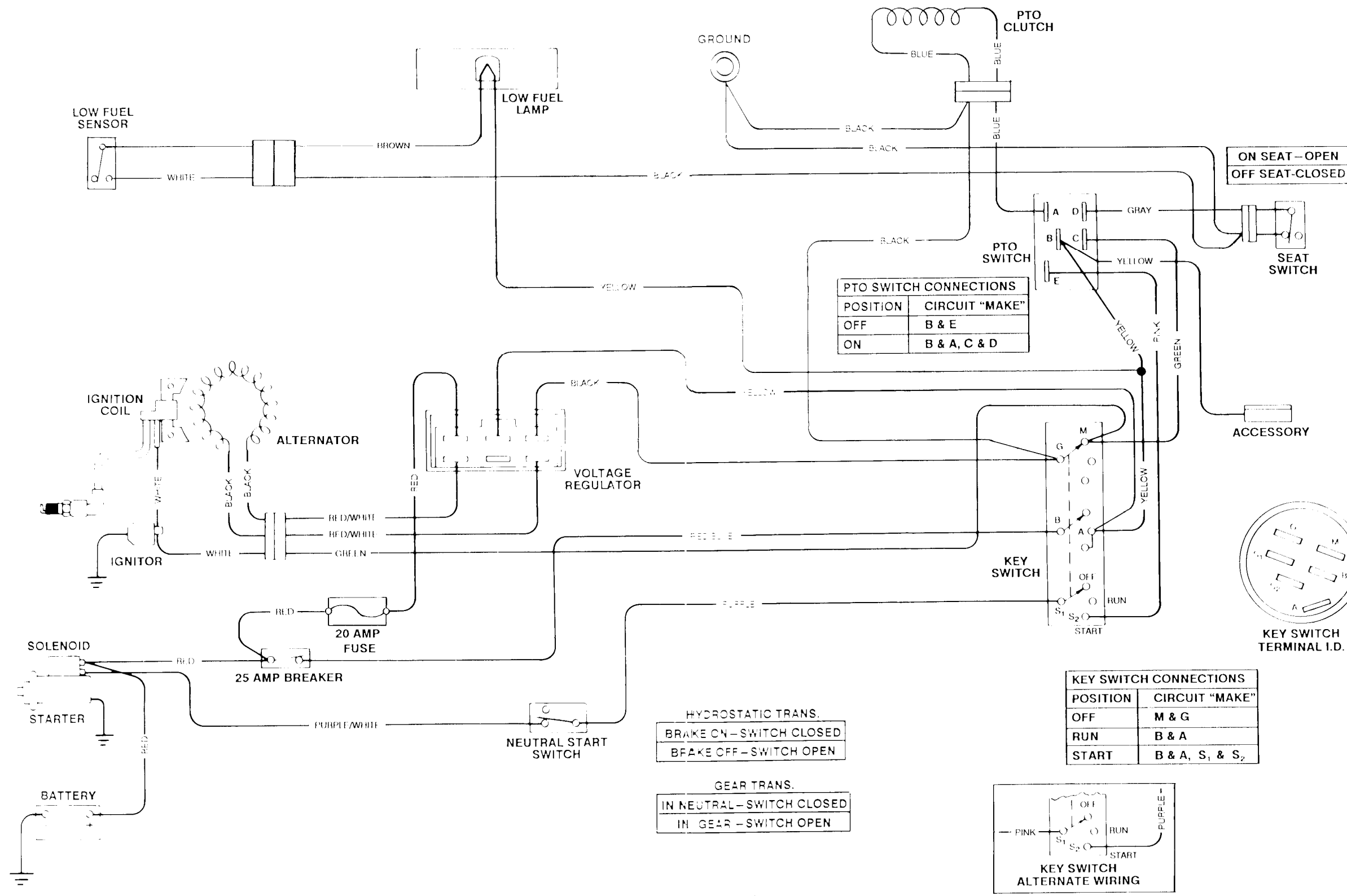

WIRING SCHEMATIC - 160 TRACTOR (S.N. 428431 - )  
 165 TRACTOR (S.N. 425969 - )



Theory of Operation

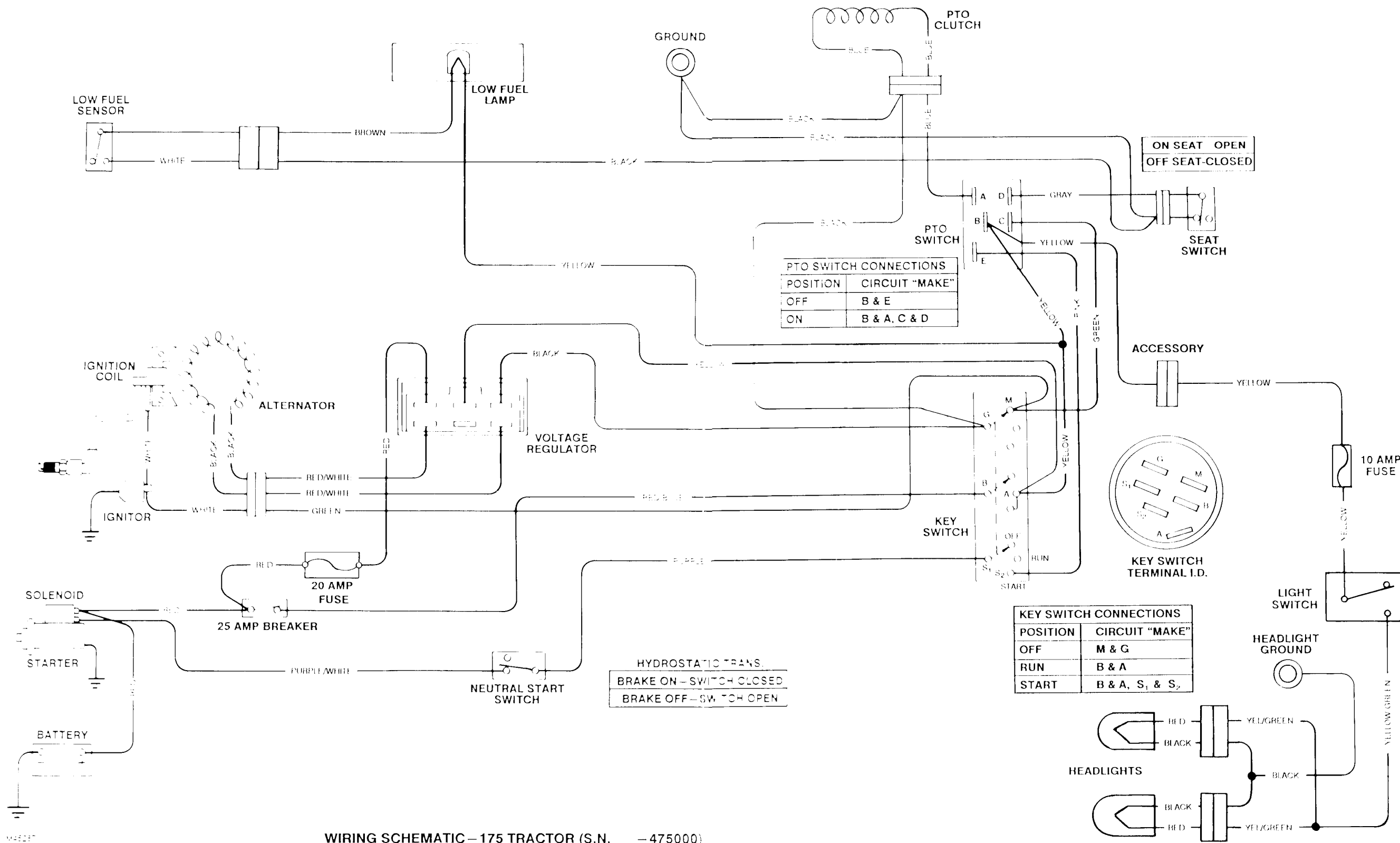

WIRING SCHEMATIC - 175 TRACTOR (S.N. - 475000)

Theory of Operation

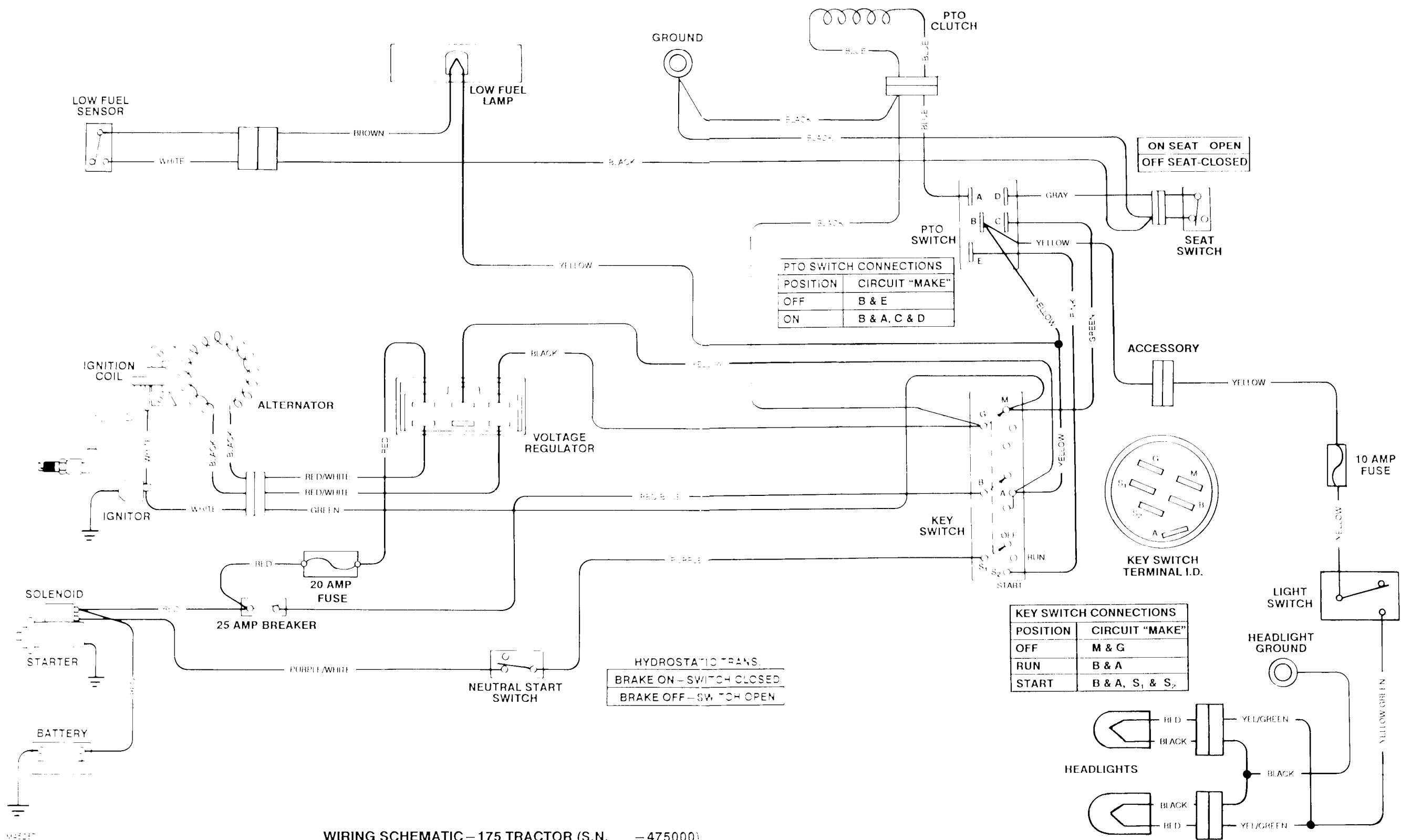

WIRING SCHEMATIC - 175 TRACTOR (S.N. - 475000)

Theory of Operation

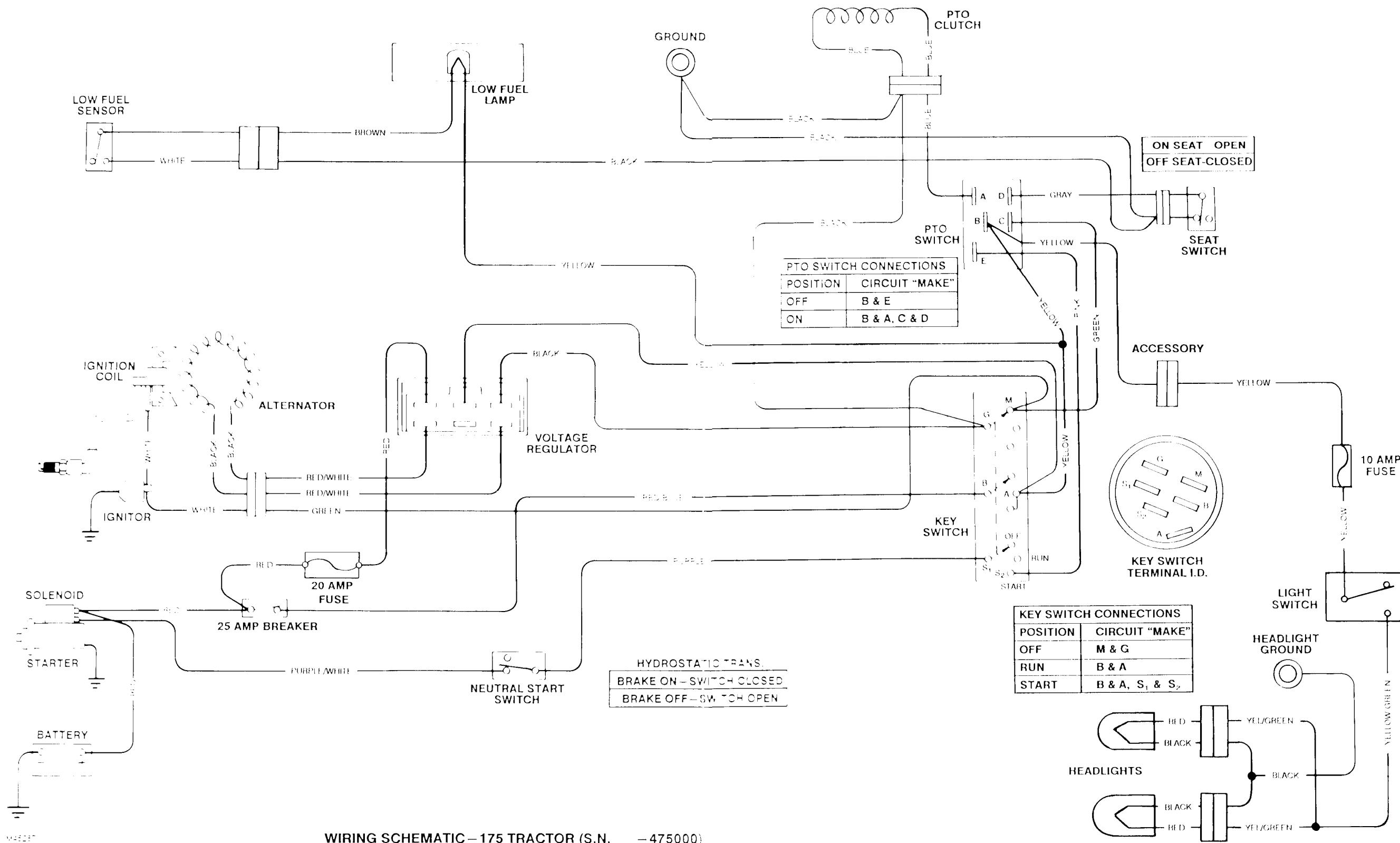

WIRING SCHEMATIC - 175 TRACTOR (S.N. - 475000)

Theory of Operation

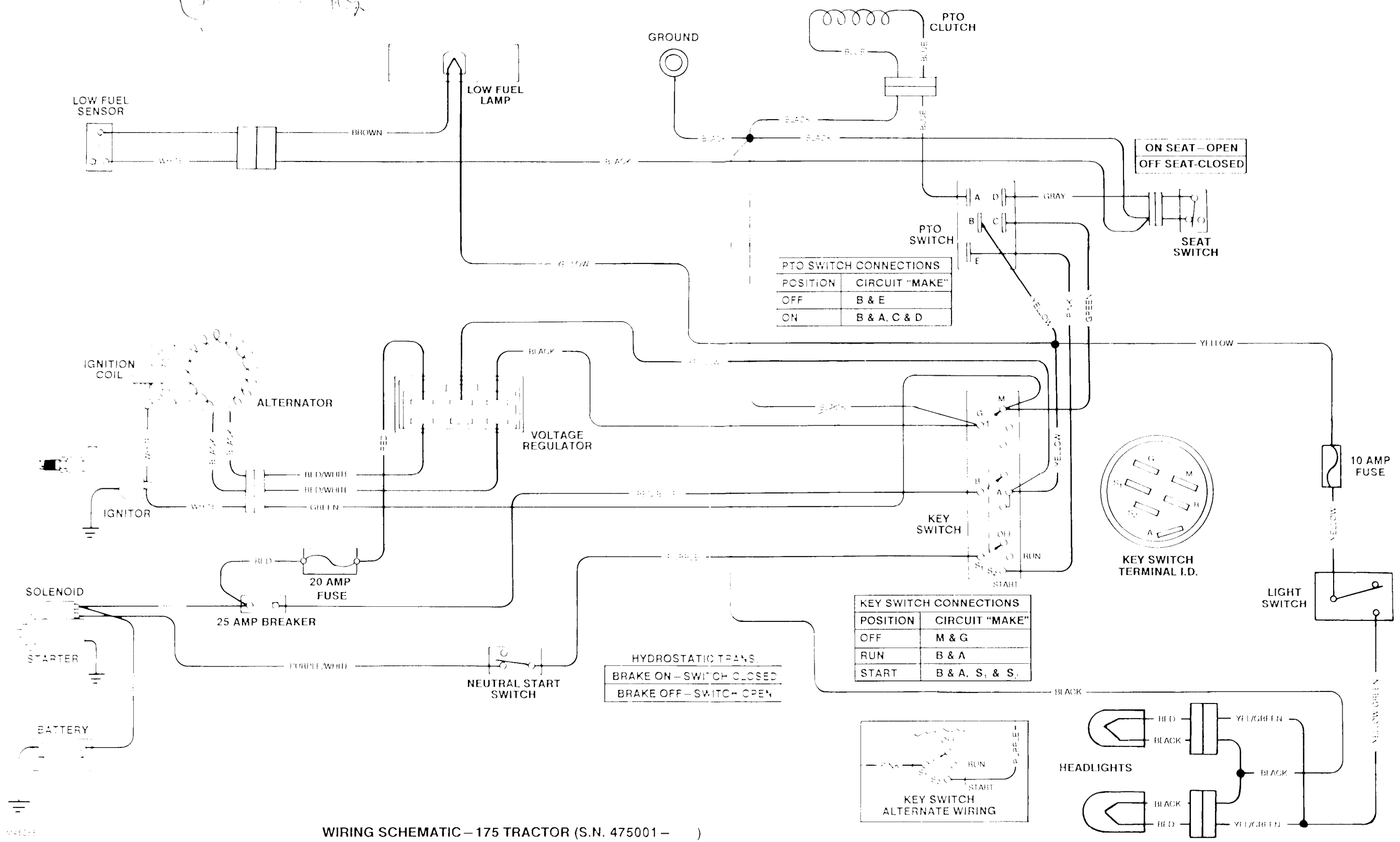

WIRING SCHEMATIC - 175 TRACTOR (S.N. 475001 - )

Theory of Operation

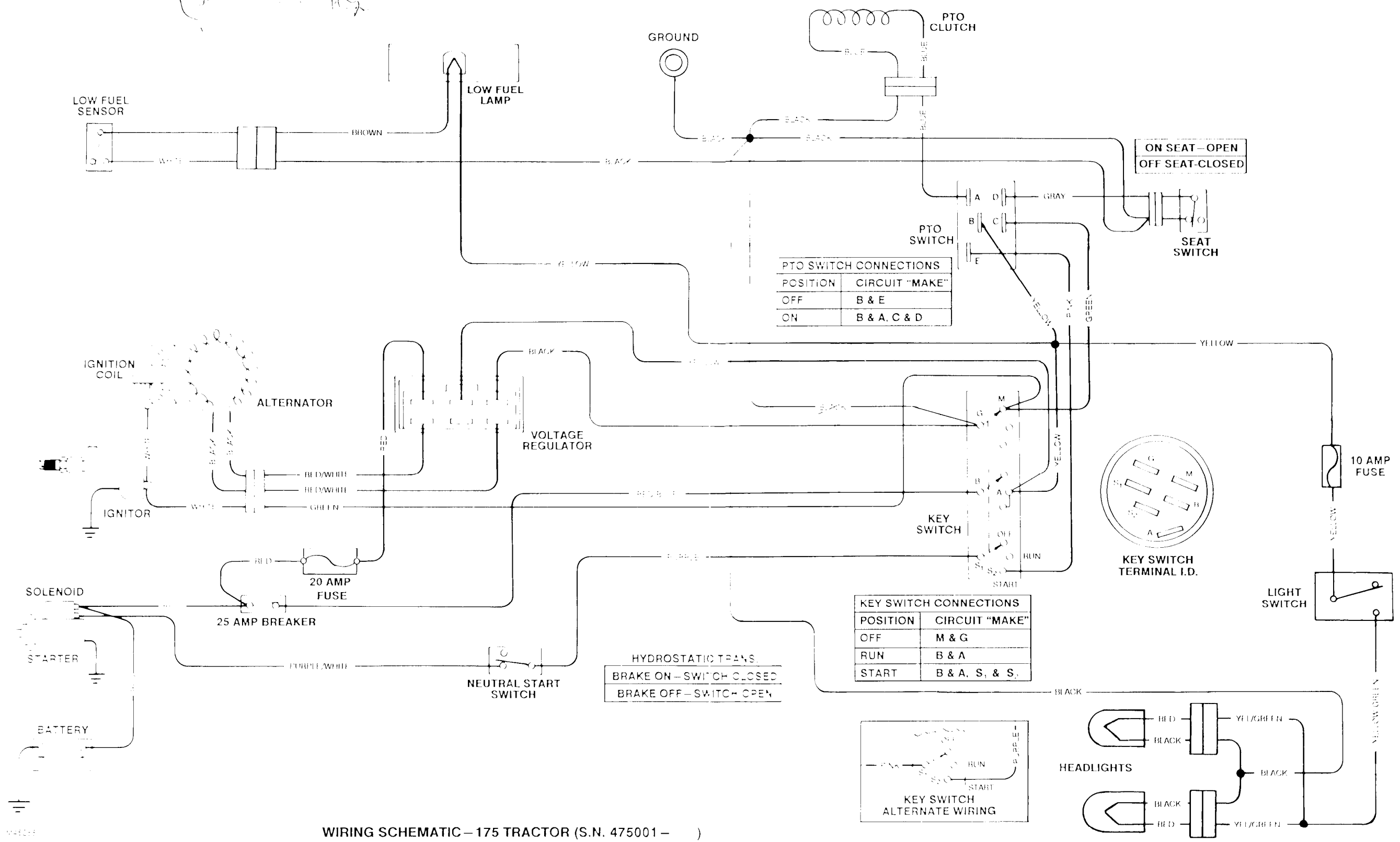

WIRING SCHEMATIC - 175 TRACTOR (S.N. 475001 - )

Theory of Operation

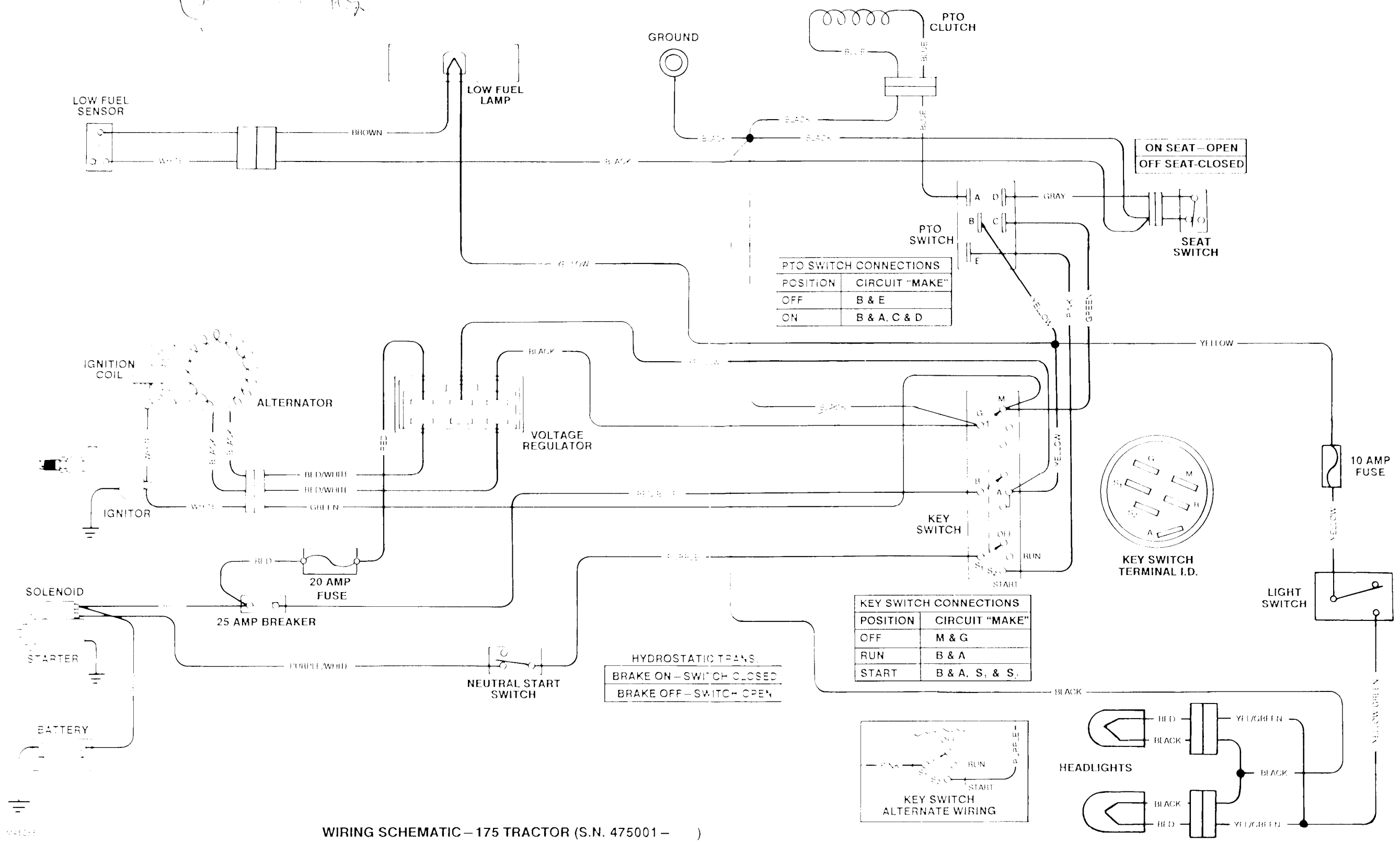

WIRING SCHEMATIC - 175 TRACTOR (S.N. 475001 - )



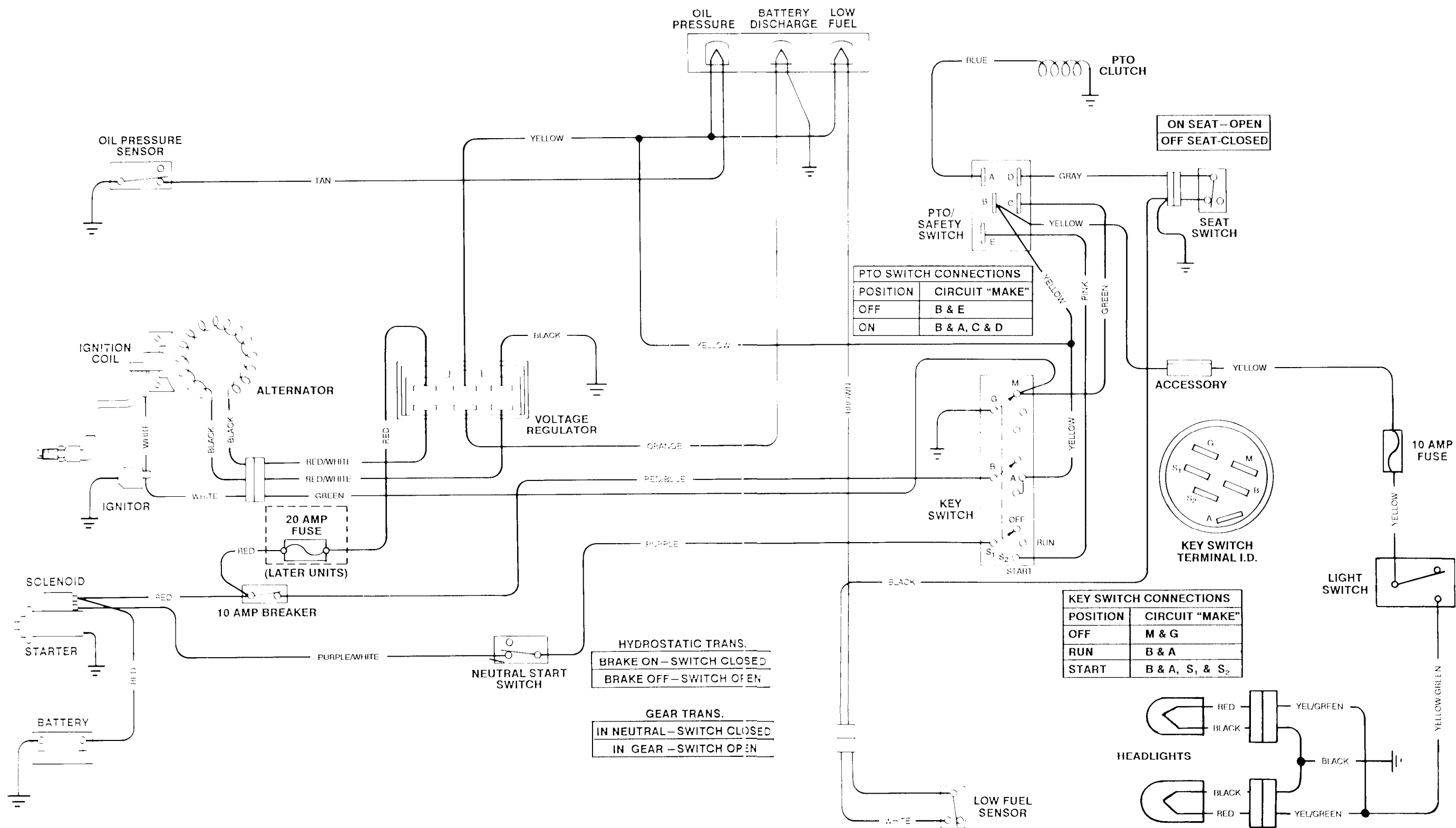

WIRING SCHEMATIC - 180 AND 185 TRACTORS (S.N. - 475000)

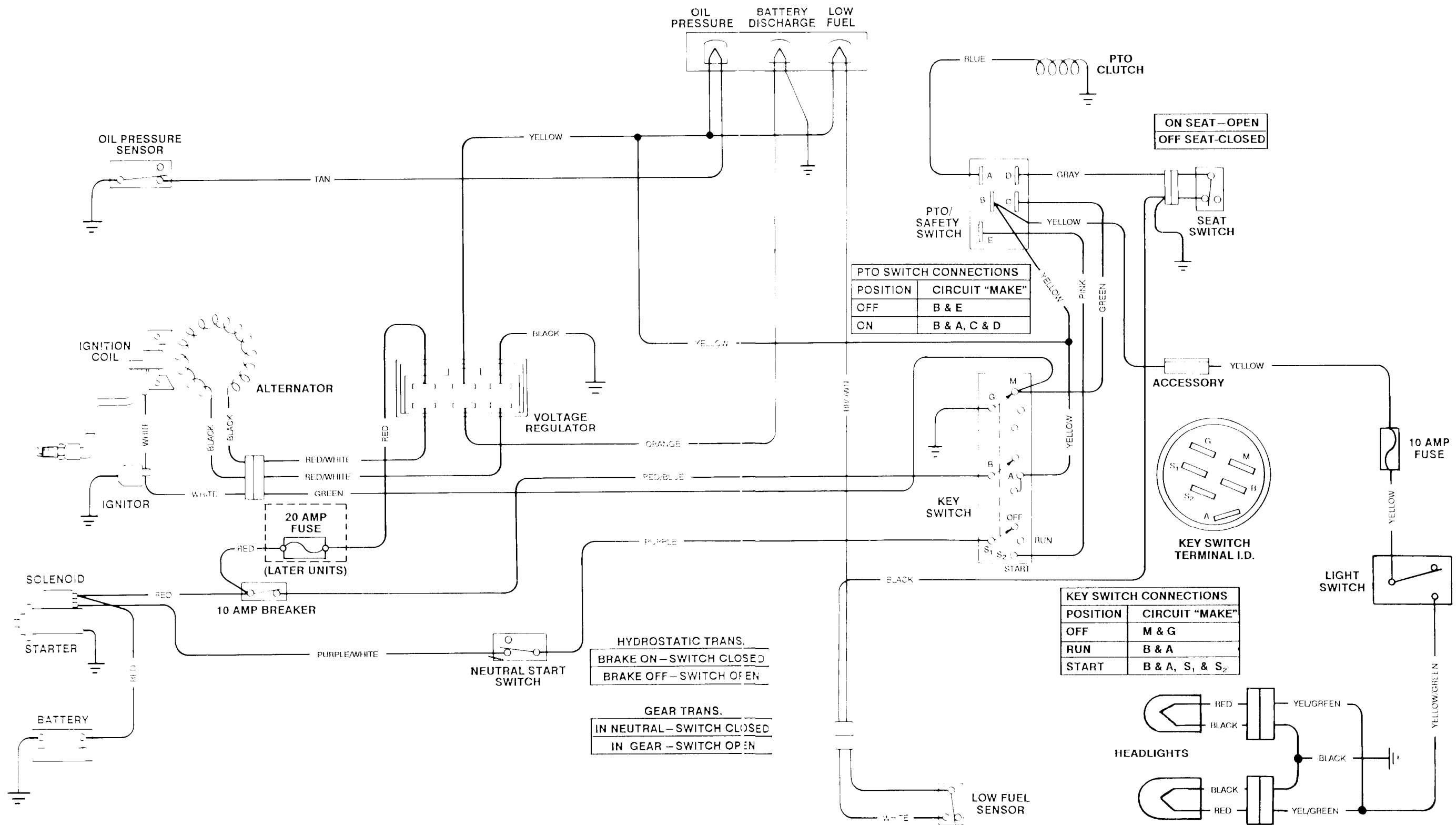

WIRING SCHEMATIC - 180 AND 185 TRACTORS (S.N. - 475000)

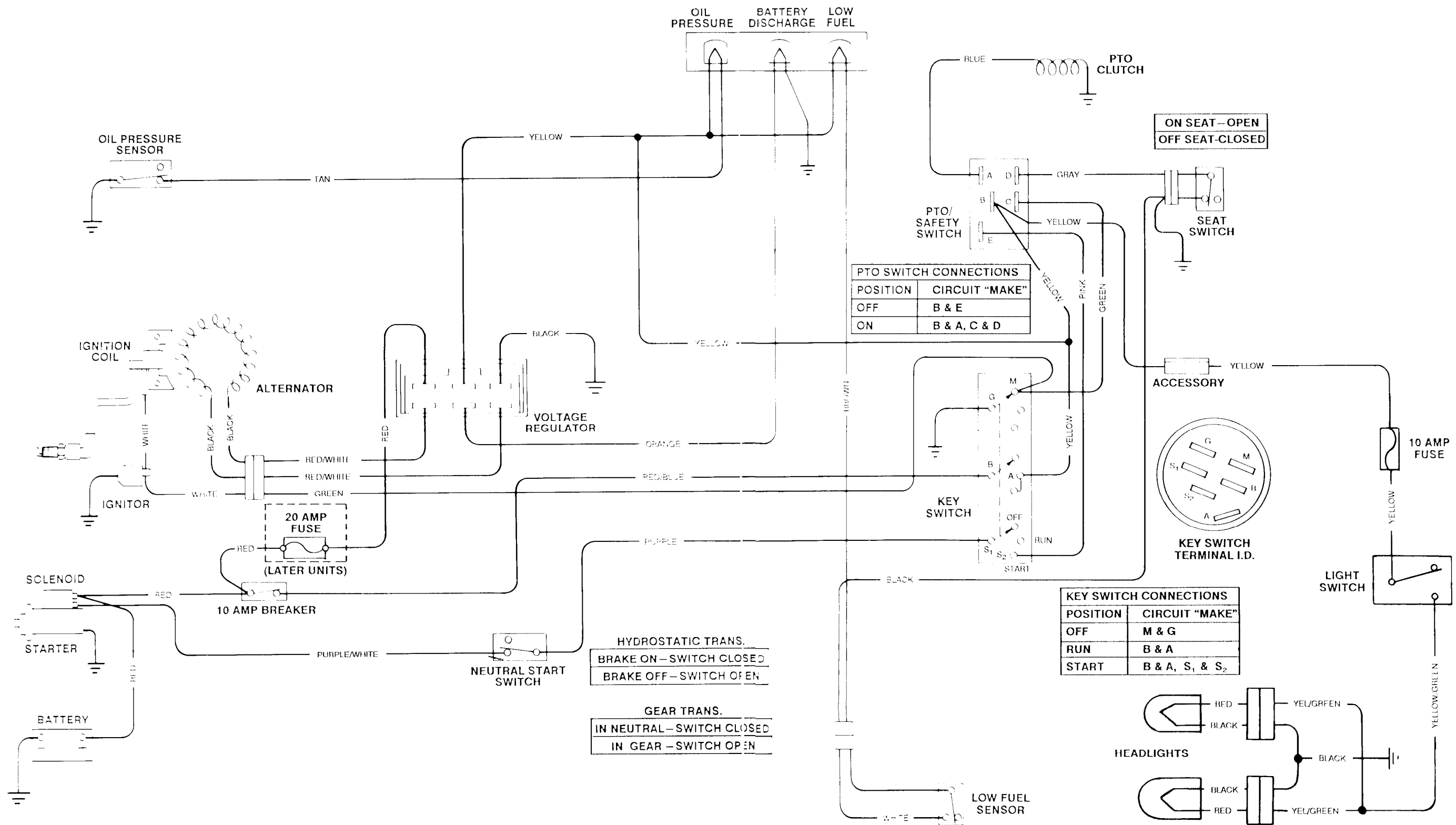

**PTO SWITCH CONNECTIONS**

POSITION	CIRCUIT "MAKE"
OFF	B & E
ON	B & A, C & D

**KEY SWITCH CONNECTIONS**

POSITION	CIRCUIT "MAKE"
OFF	M & G
RUN	B & A
START	B & A, S <sub>1</sub> & S <sub>2</sub>

**HYDROSTATIC TRANS.**  
 BRAKE ON - SWITCH CLOSED  
 BRAKE OFF - SWITCH OPEN

**GEAR TRANS.**  
 IN NEUTRAL - SWITCH CLOSED  
 IN GEAR - SWITCH OPEN

WIRING SCHEMATIC - 180 AND 185 TRACTORS (S.N. - 475000)

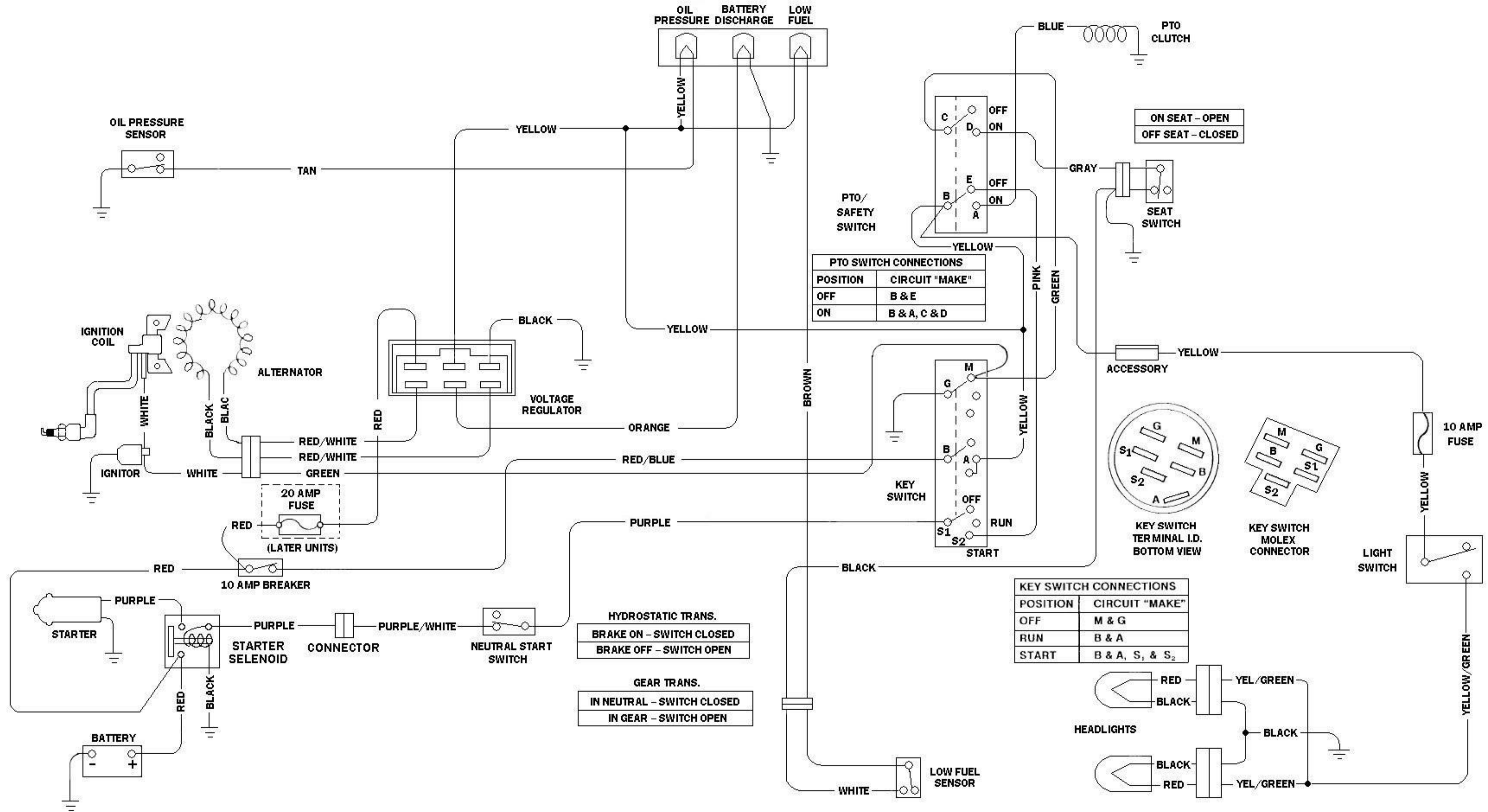

WIRING SCHEMATIC - 180 AND 185 TRACTORS (S.N. - 475000 ORS)

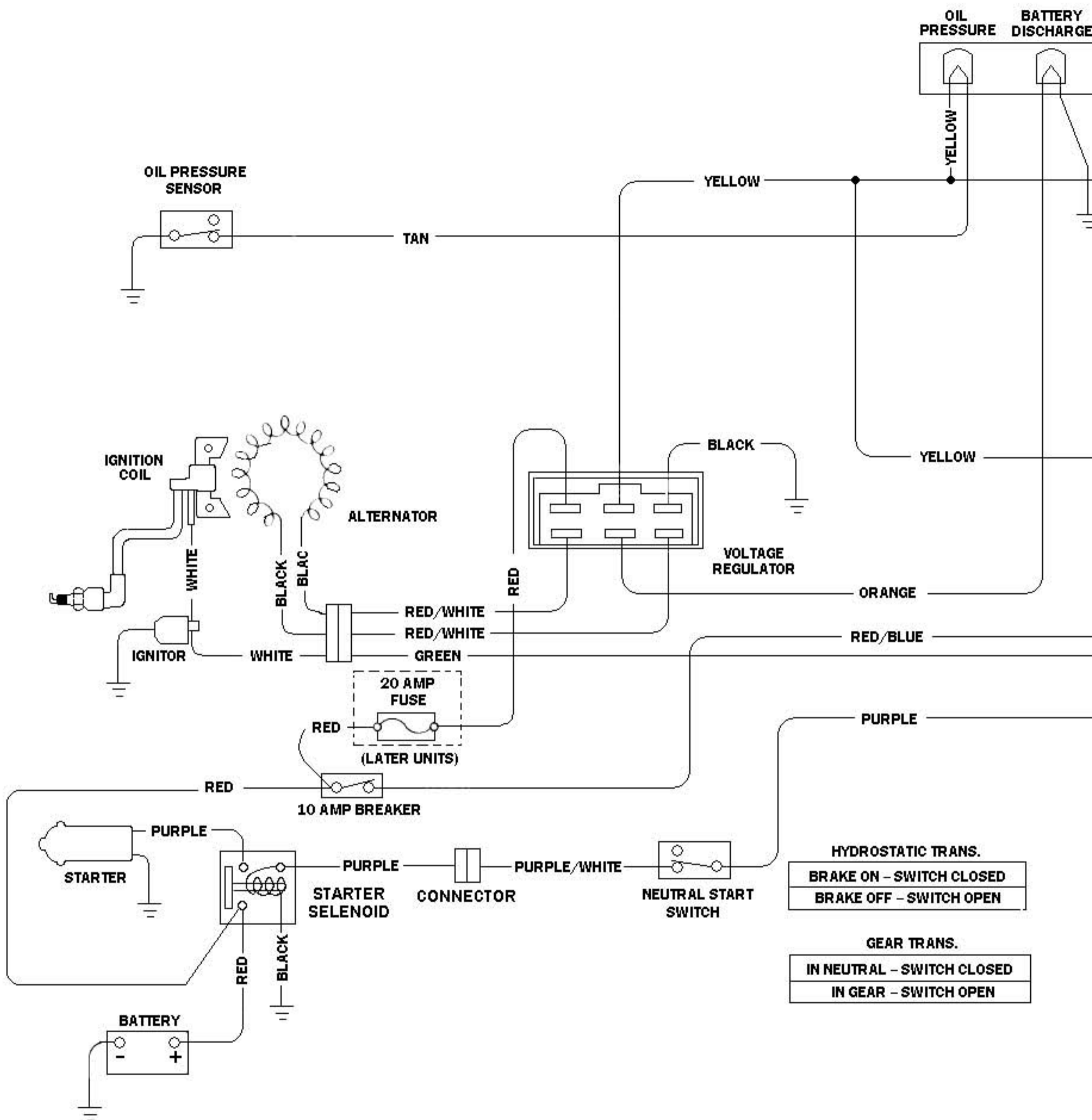

WIRING SCHEMATIC - 180 AND 185 TRACTORS (S.N. - 475000 ORS)

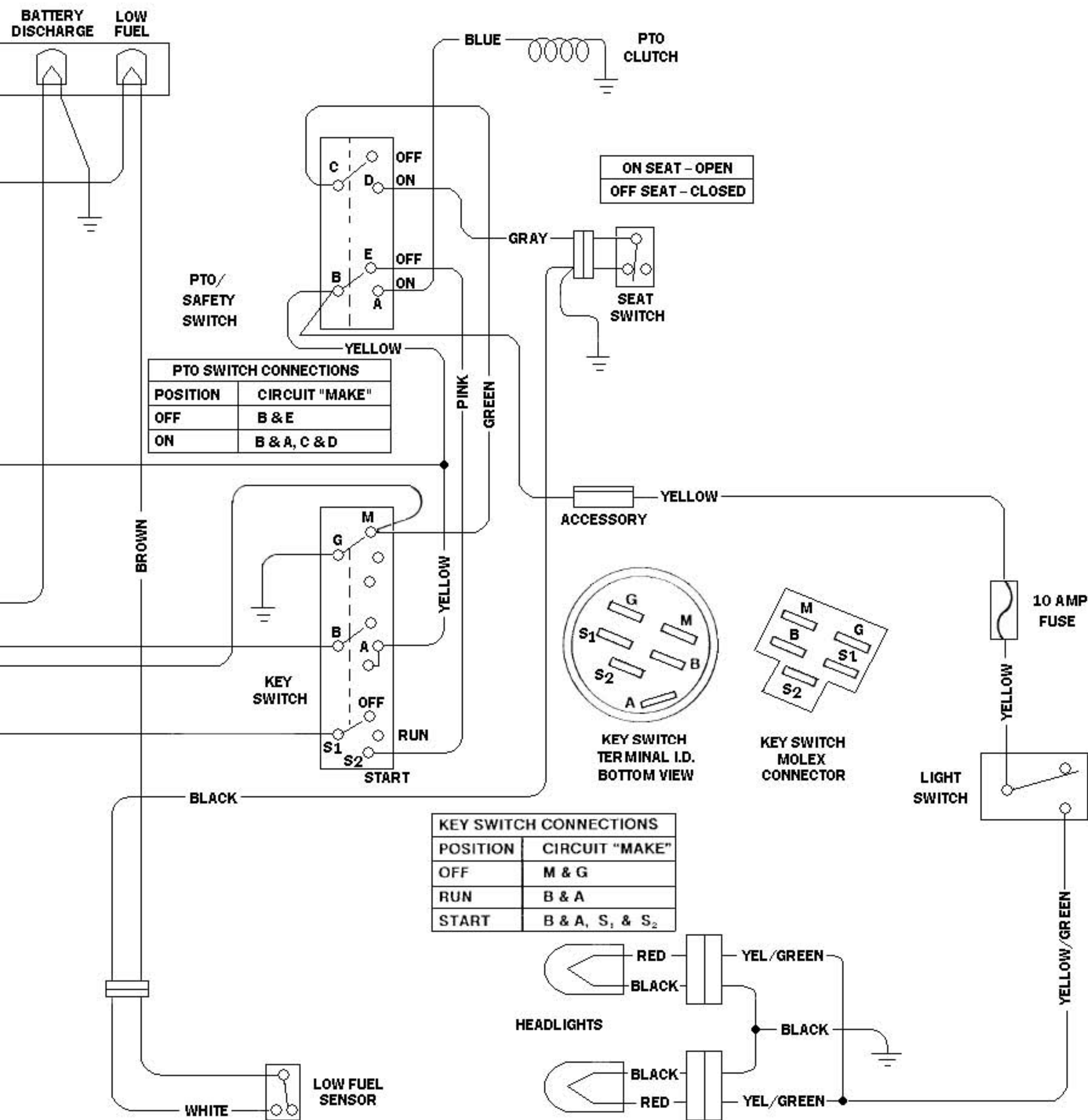

WIRING SCHEMATIC - 180 AND 185 TRACTORS (S.N. - 475000 ORS)

# Section 250

# POWER TRAIN OPERATION AND TESTS

## Contents

	Page	Page
<b>Group 05—Hydrostatic Power Train System Checkout</b>		
Transmission Neutral Check . . . . .	250-05-1	
Hydrostatic Lever Friction Check . . . . .	250-05-2	
Transmission Drive Check . . . . .	250-05-2	
<b>Group 06—Gear Power Train System Checkout</b>		
Transmission		
Neutral Check . . . . .	250-06-1	
Drive Belt Tension Check . . . . .	250-06-1	
Drive Check . . . . .	250-06-2	
<b>Group 10—Hydrostatic Power Train System Diagnosis</b>		
Transmission Operating Test . . . . .	250-10-1	
Transmission Neutral Adjustment (Eaton Transmission) . . . . .	250-10-3	
(Sundstrand Transmission) . . . . .	250-10-4	
Hydrostatic Lever Friction Adjustment . . .	250-10-5	
Check Manual Push Valve (Eaton Transmission) . . . . .	250-10-5	
(Sundstrand Transmission) . . . . .	250-10-6	
Check Belt and Idlers (Eaton Transmission) . . . . .	250-10-6	
(Sundstrand Transmission) . . . . .	250-10-6	
Check Control Linkage (Eaton Transmission) . . . . .	250-10-6	
(Sundstrand Transmission) . . . . .	250-10-6	
Check Axle/Wheel Keys . . . . .	250-10-6	
Check Transmission Oil (Eaton Transmission) . . . . .	250-10-7	
Change Transmission Oil (Eaton Transmission) . . . . .	250-10-7	
Bleed Transmission (Eaton Transmission) .	250-10-7	
Check Transmission Oil (Sundstrand Transmission) . . . . .	250-10-8	
Change Transmission Oil (Sundstrand Transmission) . . . . .	250-10-8	
Bleed Transmission (Sundstrand transmission) . . . . .	250-10-9	
Check Transmission Mounting in Frame (Eaton Transmission) . . . . .	250-10-9	
(Sundstrand Transmission) . . . . .	250-10-9	
Check Brake Adjustment (Eaton Transmission) . . . . .	250-10-10	
(Sundstrand Transmission) . . . . .	250-10-10	
Check Transmission Fan (Eaton Transmission) . . . . .	250-10-10	
(Sundstrand Transmission) . . . . .	250-10-11	
Tractor moves Opposite of Control . . . .	250-10-11	
<b>Group 11—Gear Power Train System Diagnosis</b>		
Transmission Neutral Adjustment . . . . .	250-11-1	
Transmission Drive Belt Adjustment . . . .	250-11-2	
Transmission Drive Test . . . . .	250-11-2	
Tractor Moves with Jerky or Erratic Motion . . . . .	250-11-2	
Transaxle Inspection . . . . .	250-11-3	
Transaxle is Noisy . . . . .	250-11-3	
Transmission Freewheels or Jumps Out of gear . . . . .	250-11-3	
Tractor will not Move or Stalls Easily . . .	250-11-4	
Brake Adjustment . . . . .	250-11-4	
Transmission Hard to Shift . . . . .	250-11-4	
<b>Group 15—Hydrostatic Power Train</b>		
Transmission Operation . . . . .	250-15-1	
Brake Operation . . . . .	250-15-2	
<b>Group 16—Gear Drive Power Train</b>		
Transaxle Operation . . . . .	250-16-1	
Traction Clutch Operation . . . . .	250-16-2	
Brake Operation . . . . .	250-16-3	





# Group 05 Hydrostatic Power Train System Checkout

250  
05  
1

## BEFORE YOU START

Always begin with this group to identify a failure in the power train. The step-by-step procedures will provide you with a quick check of the system. No tools are required to perform these checks. If a failure is indicated, you will be referred to a more detailed check, adjustment, or test.

Always start with the first step and follow the sequence from left to right. Read each step completely before performing the check. This procedure is designed as a quick check of the system. While performing the check, concentrate only on the check you are performing and disregard signals from unrelated components.

M21,25005S,1 -19-21JAN87

### 1 TRANSMISSION NEUTRAL CHECK

Move hydrostatic control lever to full forward, then full reverse position.

Depress brake pedal.

*LOOK: Hydrostatic lever must move to neutral position from forward and reverse.*

M21,25005,1 -19-25MAY89

Start and run engine at half throttle.



M43380 -UN-12JAN90



M43382 -UN-12JAN90

Move hydrostatic control lever to neutral position.

*LOOK: Tractor must not creep in neutral.*



M43381 -UN-12JAN90



**OK: GO TO 2**

**NOT OK: GO TO 2A**  
GROUP 10 FOR  
EATON TRANS.

**2B** GROUP 10 FOR  
SUNDSTRAND  
TRANS.

M21,25005S,2 -19-25MAY89

## Hydrostatic Power Train System Checkout/Transmission Drive Check

<p><b>2 HYDROSTATIC LEVER FRICTION CHECK</b></p> <p>Start and run engine at fast idle.</p>	 <p>M43383 -UN-12JAN90</p>	<p>Move hydrostatic lever to slow forward position.</p> <p><i>LOOK: Hydrostatic lever must move freely and not move after release.</i></p>	<p><b>OK: GO TO 3</b></p> <p><b>NOT OK: GO TO 3 GROUP 10</b></p> <p>M21,25005S,3 -19-25MAY89</p>
<p><b>3 TRANSMISSION DRIVE CHECK</b></p> <p>Start and run engine at fast idle. Operate tractor under no-load and then under load conditions.</p>	 <p>M43384 -UN-12JAN90</p>	<p>Move hydrostatic lever from slow forward to full forward to full reverse.</p> <p><i>LOOK: Tractor must move and increase speed, slow down, change direction and increase speed as lever is moved from full forward to full reverse.</i></p> <p><i>FEEL: Speed increase must be smooth.</i></p>	<p><b>OK: GO TO 4</b></p> <p><b>NOT OK: GO TO 1 GROUP 10.</b></p> <p>M21,25005S,4 -19-25MAY89</p>
<p><b>4 OPERATOR COMPLAINT NOT FOUND</b></p>	<p>If you completed the checkout procedure and did not isolate a malfunction, the problem may be intermittent.</p> <p>Try to duplicate the conditions of the malfunction identified by the operator.</p>	<p>Repeat system checkout in this group.</p>	<p>IF MALFUNCTION IS NOT IDENTIFIED AFTER REPEATING SYSTEM CHECKOUT PROCEDURE; FACTORY ASSISTANCE IS AVAILABLE THROUGH THE DEALER TECHNICAL ASSISTANCE CENTER (DTAC).</p> <p>M21,25005S,5 -19-14OCT86</p>

250  
05  
2

# Group 06

## Gear Power Train System Checkout

250  
06  
1

### BEFORE YOU START

Always begin with this group to identify a failure in the power train. The step-by-step procedures will provide you with a quick check of the system. No tools are required to perform these checks. If a failure is indicated, you will be referred to a more detailed check, adjustment, or test.

Always start with the first step and follow the sequence from left to right. Read each step completely before performing the check. This procedure is designed as a quick check of the system. While performing the check, concentrate only on the check you are performing and disregard signals from unrelated components.

M21,25006S,1 -19-21JAN87

#### 1 TRANSMISSION NEUTRAL CHECK

Park tractor on level surface.  
Stop engine.  
Disengage park brake.



M43429 -UN-12JAN90

Put transmission control lever in neutral position.  
Push tractor to see if wheels turn.

*LOOK: Wheels must turn indicating transmission is in neutral.*

*LOOK: Transmission control lever must be centered in neutral slot on right tractor fender.*

**OK:** GO TO 2  
**NOT OK:** GO TO 1 GROUP 11

M21,25006S,2 -19-21JAN87

#### 2 TRANSMISSION DRIVE BELT TENSION CHECK

Start and run engine at half throttle.



M43430 -UN-12JAN90

Operate tractor in gear 3.

*LOOK: Drive belt should not slip.*

*LISTEN: Drive belt should run quiet and not vibrate.*

*FEEL: Tractor must move forward smoothly.*

**OK:** GO TO 3  
**NOT OK:** GO TO 2 GROUP 11

M21,25006S,3 -19-21JAN87

Gear Power Train System Checkout/Transmission

**3 TRANSMISSION DRIVE CHECK**

Start and run engine at fast idle. Operate tractor under no-load and then under load condition.



M43431 -UN-12JAN90

Operate tractor in all five forward gears and in reverse.

*LOOK: Tractor must move with a noticeable change of speed in each gear.*

*LISTEN: Transmission should not make excessive noise or a ratcheting sound.*

*FEEL: Travel should be smooth in reverse and forward gears.*

**OK: GO TO 4**

**NOT OK: GO TO 3 GROUP 11**

M21,25006S,4 -19-21JAN87

**4 OPERATOR COMPLAINT NOT FOUND**

If you completed the checkout procedure and did not isolate a malfunction, the problem may be intermittent.

Try to duplicate the condition of the malfunction identified by the operator.

Repeat system checkout in this group.

**IF MALFUNCTION IS NOT IDENTIFIED AFTER REPEATING SYSTEM CHECKOUT PROCEDURE; FACTORY ASSISTANCE IS AVAILABLE THROUGH THE DEALER TECHNICAL ASSISTANCE CENTER (DTAC).**

M21,25006S,5 -19-14OCT86

250  
06  
2

# Group 10

## Hydrostatic Power Train System Diagnosis

250  
10  
1

### ABOUT THIS GROUP

Always perform the system checkout procedure in Group 05 BEFORE making any tests or adjustments in this group. The step-by-step procedures in this group provide you with the detailed diagnostic information you will need to isolate a malfunction. Basic diagnostic equipment is used.

It is assumed that you are familiar with the machine and its power train components. If you need additional information, read the theory of operation in Group 15.

Complete the following visual checks before doing any tests or adjustments:

Oil level and condition, external leaks and loose linkage.

Always start with the first step and follow the sequence from left to right. Read each step completely before performing the test.

Upon completing a test or adjustment, check to see whether the problem is corrected by performing the checkout procedure in Group 05.

M21,25010S,1 -19-14OCT86

#### 1 TRANSMISSION OPERATING TESTS

If unit does not operate properly, select the appropriate symptom.

- Tractor will not move in either direction: GO TO **A**
- Tractor moves in only one direction: GO TO **B**
- Tractor moves with jerky or erratic motion: GO TO **C**
- Tractor slow in either or both directions: GO TO **D**
- Tractor wheels stall easily: GO TO **E**
- Transmission operates hot: GO TO **F**
- Tractor slows going up hill/speeds going down: GO TO **G**
- Transmission is noisy (whines): GO TO **H**
- Transmission will not return to neutral when brakes applied: GO TO **J**
- Cannot locate neutral with transmission control: GO TO **K**
- Control linkage slips toward neutral: GO TO **3**
- Tractor moves in opposite direction of control: GO TO **12**

M21,25010,2 -19-25MAY89

#### **A** Tractor Will Not Move In Either Direction

- Check control linkage: **6A** (Eaton) or **6B** (Sundstrand)
- Check belt and idlers: GO TO **5A** (Eaton) or **5B** (Sundstrand)
- Check manual push valve: GO TO **4A** (Eaton) or **4B** (Sundstrand)
- Check axle/wheel keys: GO TO **7**
- Check transmission oil: GO TO **8A** (Eaton) or **8B** (Sundstrand)
- Check transmission internal parts: GO TO Section 50 Group 20 (Eaton) or 21 (Sundstrand)
- Check differential internal parts: GO TO Section 50 Group 25 (Eaton) or 26 (Sundstrand)

M21,25010,3 -19-25MAY89

Hydrostatic Power Train System Diagnosis/Transmission Operating Test

250  
10  
2



<p><b>B</b> Tractor Moves In Only One Direction</p>	<ul style="list-style-type: none"> <li>-Check control linkage: <b>6A</b> (Eaton) or <b>6B</b> (Sundstrand)</li> <li>-Check manual push valve: GO TO <b>4A</b> (Eaton Transmission)</li> <li>-Check transmission check valves: <b>4B</b> (Sundstrand)</li> <li>-Check transmission internal parts: GO TO Section 50 Group 20 (Eaton) or 21 (Sundstrand)</li> </ul> <p style="text-align: right;">M21,25010,4 -19-25MAY89</p>
<p><b>C</b> Tractor Moves With Jerky Or Erratic Motion</p>	<ul style="list-style-type: none"> <li>-Check belt and idlers: GO TO <b>5A</b> (Eaton) or <b>5B</b> (Sundstrand)</li> <li>-Check manual push valve: GO TO <b>4A</b> (Eaton) or <b>4B</b> (Sundstrand)</li> <li>-Check transmission oil: GO TO <b>8A</b> (Eaton) or <b>8B</b> (Sundstrand)</li> <li>-Check transmission mounting in frame: GO TO <b>9A</b> (Eaton) or <b>9B</b> (Sundstrand)</li> <li>-Check transmission internal parts: GO TO Section 50 Group 20 (Eaton) or 21 (Sundstrand)</li> <li>-Check differential internal parts: GO TO Section 50 Group 25 (Eaton) or 26 (Sundstrand)</li> </ul> <p style="text-align: right;">M21,25010,5 -19-25MAY89</p>
<p><b>D</b> Tractor Slow In Either Or Both Directions</p>	<ul style="list-style-type: none"> <li>-Check belt and idlers: GO TO <b>5A</b> (Eaton) or <b>5B</b> (Sundstrand)</li> <li>-Check control linkage: GO TO <b>6A</b> (Eaton) or <b>6B</b> (Sundstrand)</li> <li>-Check brake adjustment: GO TO <b>10A</b> (Eaton) or <b>10B</b> (Sundstrand)</li> <li>-Check manual push valve: GO TO <b>4A</b> (Eaton) or <b>4B</b> (Sundstrand)</li> <li>-Check transmission oil: GO TO <b>8A</b> (Eaton) or <b>8B</b> (Sundstrand)</li> <li>-Check transmission internal parts: GO TO Section 50 Group 20 (Eaton) or 21 (Sundstrand)</li> </ul> <p style="text-align: right;">M21,25010,6 -19-25MAY89</p>
<p><b>E</b> Tractor Wheels Stall Easily</p>	<ul style="list-style-type: none"> <li>-Check belt and idlers: GO TO <b>5A</b> (Eaton) or <b>5B</b> (Sundstrand)</li> <li>-Check manual push valve: GO TO <b>4A</b> (Eaton) or <b>4B</b> (Sundstrand)</li> <li>-Check transmission oil: GO TO <b>8A</b> (Eaton) or <b>8B</b> (Sundstrand)</li> <li>-Check transmission internal parts: GO TO Section 50 Group 20 (Eaton) or 21 (Sundstrand)</li> </ul> <p style="text-align: right;">M21,25010,7 -19-25MAY89</p>
<p><b>F</b> Transmission Operates Hot</p>	<ul style="list-style-type: none"> <li>-Check belt and idlers: GO TO <b>5A</b> (Eaton) or <b>5B</b> (Sundstrand)</li> <li>-Check transmission fan: GO TO <b>11A</b> (Eaton) or <b>11B</b> (Sundstrand)</li> <li>-Check transmission oil: GO TO <b>8A</b> (Eaton) or <b>8B</b> (Sundstrand)</li> <li>-Check transmission internal parts; GO TO Section 50 Group 20 (Eaton) or 21 (Sundstrand)</li> </ul> <p style="text-align: right;">M21,25010,8 -19-25MAY89</p>
<p><b>G</b> Tractor Slows Going Up Hill/Speeds Going Down</p>	<ul style="list-style-type: none"> <li>-Check belt and idlers: GO TO <b>5A</b> (Eaton) or <b>5B</b> (Sundstrand)</li> <li>-Check transmission oil: GO TO <b>8A</b> (Eaton) or <b>8B</b> (Sundstrand)</li> <li>-Check transmission internal parts: GO TO Section 50 Group 20 (Eaton) or 21 (Sundstrand)</li> </ul> <p style="text-align: right;">M21,25010,9 -19-25MAY89</p>

Hydrostatic Power Train System Diagnosis/Transmission Neutral Adjustment (Eaton Transmission)

<p><b>H</b> Transmission Is Noisy</p>	<p>-Check control linkage: GO TO <b>6A</b> (<b>8A</b> (Eaton) or <b>8B</b> (Sundstrand) (Eaton) or <b>6B</b> (Sundstrand))                  -Check return to neutral adjustment: GO TO <b>2A</b> or <b>2B</b>                  -Check belt and idlers: GO TO <b>5A</b> (Eaton) or <b>5B</b> (Sundstrand)                  -Check transmission fan: GO TO <b>11A</b> (Eaton) or <b>11B</b> (Sundstrand)                  -Check transmission oil: GO TO</p> <p style="text-align: right;">-Check transmission internal parts: GO TO Section 50 Group 20 (Eaton) or 21 (Sundstrand)</p> <p style="text-align: right;">M21,25010,10 -19-25MAY89</p>
---------------------------------------	--

<p><b>J</b> Transmission Will Not Return To Neutral When Brakes Applied</p>	<p>-Check control linkage: GO TO <b>6A</b> (Eaton) or <b>6B</b> (Sundstrand)                  -Check return to neutral adjustment: GO TO <b>2A</b> (Eaton) or <b>2B</b> (Sundstrand)                  -Check transmission mounting in frame: GO TO <b>9A</b> (Eaton) or <b>9B</b> (Sundstrand)                  -Check lever friction adjustment: GO TO <b>3</b></p> <p style="text-align: right;">M21,25010,11 -19-25MAY89</p>
---	---



<p><b>K</b> Cannot Locate Neutral With Transmission Control</p>	<p>-Check control linkage: GO TO <b>6A</b> (Eaton) or <b>6B</b> (Sundstrand)                  -Check transmission mounting in frame: GO TO <b>9A</b> (Eaton) or <b>9B</b> (Sundstrand)                  -Check lever friction adjustment: GO TO <b>3</b></p> <p style="text-align: right;">M21,25010,12 -19-25MAY89</p>
---	---

<p><b>2A</b> TRANSMISSION NEUTRAL ADJUSTMENT (EATON TRANSMISSION)</p> <p>Park tractor safely.</p> <p>lift rear wheels off the ground using a hoist.</p> <p>Put jackstands under frame.</p>	 <p>Move hydrostatic control lever to neutral position.</p> <p>Disconnect brake linkage (A).</p> <p>BLK</p> <p style="font-size: small;">M43385 -UN-12JAN90</p>	 <p>Disconnect ball joint from hydrostatic control lever (B).</p> <p>Engage park brake.</p> <p style="font-size: small;">M43386 -UN-12JAN90</p>
--	--	---

<p><b>⚠ CAUTION: USE EXTREME CAUTION WHEN PERFORMING THIS ADJUSTMENT BECAUSE DRIVE WHEELS ARE FREE TO SPIN.</b></p>	<p>Start engine.</p>	 <p>Loosen jam nut and turn adjusting bolt (C) until rear wheels stop turning. Tighten jam nut.</p> <p>Stop engine.</p> <p style="font-size: small;">M43387 -UN-12JAN90</p> <p style="text-align: right;">M21,25010S,3 -19-14OCT86</p>
---	----------------------	--

Hydrostatic Power Train System Diagnosis/(Sundstrand Transmission)

250  
10  
4

 <p>M43388 -UN-12JAN90</p>	<p>Disengage park brake. Move control arm (D) to the rear as far as it will go. There should be 0.7-2.5 mm (0.03-0.10 in.) clearance (E) between adjusting bolt and control arm.</p>	 <p>M43389 -UN-12JAN90</p>	<p>To adjust clearance (E), remove cotter pin and drilled pin. Turn yoke (F) to get correct clearance. Install drilled pin and cotter pin.</p> <p>M21,25010S,4 -19-14OCT86</p>
---	--	---	--

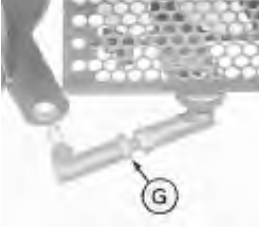
 <p>M43390 -UN-12JAN90</p>	<p>Connect brake linkage. Engage park brake. Loosen nut (G) on ball joint. Turn joint as required until it fits into control arm. Connect and tighten ball joint to control arm. Tighten nut (G).</p>	<p>A-Brake Linkage B-Control Lever C-Adjusting Bolt D-Control Arm E-Clearance F-Yoke G-Jam Nut</p>	<p>AFTER ADJUSTMENT: GO TO ① GROUP 05</p> <p>M21,25010S,5 -19-02FEB87</p>
---	---	--	---

<p><b>2B TRANSMISSION NEUTRAL ADJUSTMENT (SUNDSTRAND TRANSMISSION)</b></p> <p>Lift rear wheels off the ground using a hoist. Put jackstands under frame.</p>	<p>ART NOT FOUND M51873</p> <p>M51873 -UN-</p>	<p>Move hydrostatic control lever to neutral position. Loosen nut (C). Set park brake.</p>	<p>Move cam (B) to center roller (A) in vee. Hold cam (B) up and tighten nut (C).</p>	<p><b>⚠ CAUTION: USE EXTREME CAUTION WHEN PERFORMING THIS ADJUSTMENT BECAUSE DRIVE WHEELS ARE FREE TO SPIN AND TRANSMISSION COOLING FAN IS CLOSE.</b></p> <p>M21,25010S,6 -19-25MAY89</p>
--	--	--	---	---

<p>ART NOT FOUND M51874</p> <p>M51874 -UN-</p>	<p>Loosen nuts (A). Start engine. Turn link (B) until rear wheels stop turning. Tighten nuts (A).</p>	<p>Operate transmission in both forward and reverse. Apply brake and release.</p>	
--	---	---	--

<p><i>LOOK: Rear wheels must stop turning and remain stopped when brake is applied and released.</i></p> <p>Readjust link (C) if needed. Stop engine.</p>	<p>AFTER ADJUSTMENT: GO TO ① GROUP 05</p> <p>M21,25010S,7 -19-25MAY89</p>
---	---



**3** HYDROSTATIC LEVER FRICTION ADJUSTMENT

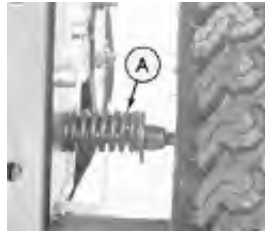

Turn nut to compress spring control lever pivot until control will hold position.

Make sure that linkage will return to neutral when brake applied.

M43391 -UN-12JAN90

AFTER ADJUSTMENT: GO TO **2** GROUP 05

M21,25010S,8 -19-25MAY89

250  
10  
5

**4A** CHECK MANUAL PUSH VALVE (EATON TRANSMISSION)

Engage park brake.

Start and run engine at full throttle.



M43393 -UN-12JAN90

Hold manual push lever to the left.

Move hydrostatic control lever to full forward position then to full reverse position several times.

Put hydrostatic control lever in neutral position, move throttle to slow idle position and release manual push lever.

M21,25010S,9 -19-25MAY89

Release park brake.



M43394 -UN-12JAN90

Move hydrostatic control lever from slow forward to full forward to full reverse.

*LOOK: Tractor must move and increase speed, slow down, change direction, and increase speed as lever is moved from full forward to full reverse.*

*FEEL: Speed increase must be smooth.*

**OK:** RETURN TO OPERATING TESTS.

**NOT OK:** CONTINUE

M21,25010S,10 -19-25MAY89

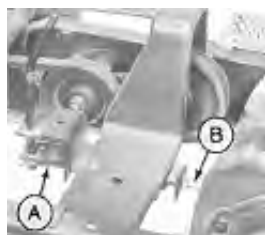

M43399 -UN-12JAN90

Inspect manual push lever linkage (A). Be sure linkage does not hold valve shaft (B) in "push" position.

Be sure valve shaft (B) is not stuck in "push" position but is free to move in and out of transmission.

**OK:** RETURN TO OPERATING TESTS.

**NOT OK:** REPAIR OR REPLACE, THEN GO TO **3** GROUP 05.

M21,25010S,11 -19-25MAY89

Hydrostatic Power Train System Diagnosis/Check Axle/Wheel Keys

250  
10  
6

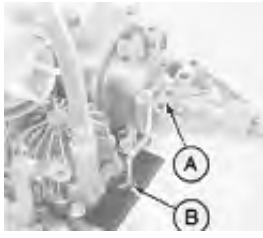
<p><b>4B</b> CHECK MANUAL PUSH VALVE (SUNDSTRAND TRANSMISSION)</p> <p>Operate manual push valve.</p>	 <p>M49246 -UN-20DEC89</p>	<p>Check for free movement of linkage (A).</p> <p>Check for free movement of push valve (B).</p>	<p><i>FEEL: Tractor should move easily when valve pushed in. Tractor should not move when valve not pushed in.</i></p>	<p><b>OK:</b> RETURN TO OPERATING TESTS.</p> <p><b>NOT OK:</b> REPAIR OR REPLACE, THEN GO TO ③ GROUP 05</p> <p>M21,25010S,12 -19-25MAY89</p>
--	---	--	--	--

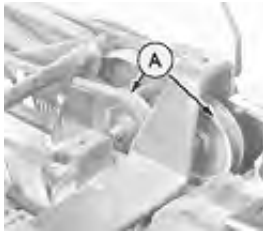
<p><b>5A</b> CHECK BELT AND IDLERS (EATON TRANSMISSION)</p>	 <p>M49398 -UN-12JAN90</p>	<p>Inspect drive belt for slippage.</p> <p>Check belt for worn or stretched areas.</p> <p>Check belt tensioning spring and idlers (A).</p>	<p><b>OK:</b> RETURN TO OPERATING TESTS.</p> <p><b>NOT OK:</b> REPAIR OR REPLACE, THEN GO TO ③ GROUP 05</p> <p>M21,25010S,13 -19-25MAY89</p>
---	---	--	--

<p><b>5B</b> CHECK BELT AND IDLERS (SUNDSTRAND TRANSMISSION)</p>	 <p>M49247 -UN-20DEC89</p>	<p>Inspect drive belt for slippage.</p> <p>Check belt for worn or stretched areas.</p> <p>Check belt tensioning spring and idlers.</p> <p>Check belt disengagement linkage.</p>	<p><b>OK:</b> RETURN TO OPERATING TESTS.</p> <p><b>NOT OK:</b> REPAIR OR REPLACE, THEN GO TO ③ GROUP 05</p> <p>M21,25010S,14 -19-25MAY89</p>
--	--	---	--

<p><b>6A</b> CHECK CONTROL LINKAGE (EATON TRANSMISSION)</p>	 <p>M43392 -UN-12JAN90</p>	<p>Inspect transmission control linkage for wear or damage.</p>	<p><b>OK:</b> RETURN TO OPERATING TESTS.</p> <p><b>NOT OK:</b> REPAIR OR REPLACE, THEN GO TO ③ GROUP 05</p> <p>M21,25010S,15 -19-25MAY89</p>
---	---	---	--

<p><b>6B</b> CHECK CONTROL LINKAGE (SUNDSTRAND TRANSMISSION)</p>	<p>ART NOT FOUND M51875</p> <p>M51875 -UN-</p>	<p>Inspect transmission control linkage for wear or damage.</p>	<p><b>OK:</b> RETURN TO OPERATING TESTS.</p> <p><b>NOT OK:</b> REPAIR OR REPLACE, THEN GO TO ③ GROUP 05</p> <p>M21,25010S,16 -19-25MAY89</p>
--	--	---	--

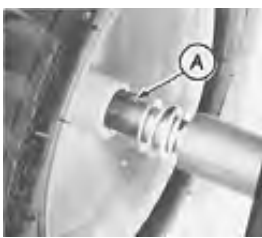
<p><b>7</b> CHECK AXLE/WHEEL KEY</p> <p>Lift the rear wheels off the ground using a hoist.</p> <p>Put jackstands under frame.</p>	 <p>M49259 -UN-20DEC89</p>	<p>Remove snap rings.</p> <p>Slide wheels partially off axles.</p> <p>Check for installation of keys (A).</p>	<p><b>OK:</b> RETURN TO OPERATING TESTS.</p> <p><b>NOT OK:</b> REPAIR, THEN GO TO ③ GROUP 05</p> <p>M21,25010S,17 -19-25MAY89</p>
---	---	---	---

Hydrostatic Power Train System Diagnosis/Bleed Transmission (Eaton Transmission)

<p><b>8A CHECK TRANSMISSION OIL (EATON TRANSMISSION)</b></p> <p>Tip seat to access reservoir.</p> <p>Remove cap.</p>	 <p>M43395 -UN-12JAN90</p>	<p>Check oil level, type, and condition. Add specified oil as needed.</p> <p><i>LOOK: Oil type must be single weight engine oil. Transmission oil, identified by a reddish color, must not be used.</i></p> <p><i>LOOK: Oil must be clear and clean. Cloudy or discolored oil indicates water contamination. Blackened oil indicates overheating.</i></p> <p>Check reservoir screen.</p>	<p><b>OK:</b> RETURN TO OPERATING TESTS.</p> <p><b>NOT OK:</b> CONTINUE.</p> <p>M21,25010S,18 -19-25MAY89</p>
--	---	--	---

<p>Change Transmission Oil. (Eaton Transmission)</p> <p>Remove fender deck-see Section 30.</p> <p>Move fuel tank to the side.</p>	 <p>M43396 -UN-12JAN90</p>	<p>Remove oil and debris from transmission and differential cases.</p> <p><b>IMPORTANT: Do not use high pressure washer. Water in the oil will damage transmission.</b></p> <p>Remove reservoir cap, vent plug (A) and drain plug (like vent plug on bottom).</p>	<p>Refill with specified oil.</p> <p>Push tractor to purge air and old oil from transmission.</p> <p>Drain, refill and bleed transmission.</p> <p>M21,25010S,19 -19-25MAY89</p>
---	--	---	---

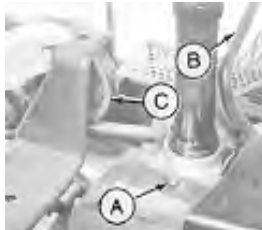
<p>Bleed Transmission (Eaton Transmission)</p> <p>Remove fender deck-see Section 30.</p> <p>Move fuel tank to the side.</p>	<p>Remove plug (A) to vent the transmission.</p> <p><b>IMPORTANT: Oil flows very slowly through the reservoir screen filter. Add only a small amount of oil at a time to avoid overfilling reservoir.</b></p>	 <p>M43397 -UN-12JAN90</p> <p>Add small amounts of specified oil to reservoir tube until it flows from vent (A).</p> <p>Move hydrostatic lever (B) to full forward position. Use a locking pliers to hold drive belt idler (C) up to release belt tension.</p>	<p>M21,25010S,20 -19-25MAY89</p>
---	---	---	----------------------------------

250  
10  
7

Hydrostatic Power Train System Diagnosis/Change Transmission Oil (Sundstrand Transmission)

250  
10  
8

<p>Push tractor forward several feet then backward to spin transmission rotating groups to purge trapped air.</p> <p>Add small amounts of oil to reservoir until oil reappears at vent, then install and tighten plug.</p> <p>Fill reservoir to oil level cold mark only.</p> <p>Do not overfill.</p>	<p><b>IMPORTANT: Any moisture in the transmission oil will cause loss of performance and damage.</b></p> <p>Keep the transmission case clean to insure adequate cooling.</p> <p>Remove the reservoir cap as little as possible to prevent contamination of this oil.</p>	<p>GO TO <b>3</b> GROUP 05</p> <p>M21,25010S,21 -19-25MAY89</p>
---	--	---

<p><b>8B CHECK TRANSMISSION OIL (SUNDSTRAND TRANSMISSION)</b></p> <p>Check oil level (cold), line (A) on tank.</p>	 <p>Check oil type and condition.</p> <p><i>LOOK: Oil type must be 10W 30 weight engine oil. Transmission oil, identified by a reddish color, must not be used.</i></p> <p><i>LOOK: Oil must be clear and clean, cloudy or discolored oil indicates water contamination. Blackened oil indicates overheating.</i></p> <p>M49245 -UN-20DEC89</p>	<p><b>OK: RETURN TO OPERATING TESTS.</b></p> <p><b>NOT OK: CONTINUE.</b></p> <p>M21,25010S,22 -19-25MAY89</p>
--	---	---

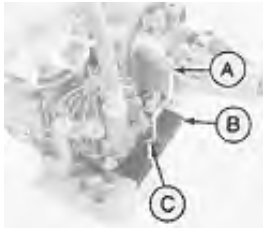

<p>Change Transmission Oil (Sundstrand Transmission)</p> <p>Remove reservoir cap.</p>	 <p>Remove manual push valve linkage (A).</p> <p>Remove bracket (B).</p> <p>Remove manual push valve (C). Drain transmission.</p> <p>Fill transmission with specified oil.</p> <p>Bleed transmission.</p> <p>M49258 -UN-20DEC89</p>	<p>M21,25010S,23 -19-25MAY89</p>
---	--	----------------------------------

## Hydrostatic Power Train System Diagnosis/(Sundstrand Transmission)

<p><b>Bleed Transmission (Sundstrand Transmission)</b></p> <p>Lift rear wheel off the ground using a hoist.</p> <p>Put jackstrands under frame.</p>	 <p style="font-size: small; margin-top: 5px;">M49245 -UN-20DEC89</p>	<p>Fill case and reservoir to fill line (A) with 10W 30 engine oil.</p> <p>Start engine. Run at low idle 2 to 3 minutes with brake released to start oil flow through transmission.</p> <p>Move transmission control to full forward. Hold for 10 seconds.</p> <p>Return transmission control to neutral. Hold for 5 seconds.</p> <p>Press manual push valve: Hold for 2 seconds.</p>
<p style="font-size: x-small;">M21,25010S,24 -19-25MAY89</p>		

250  
10  
9

<p>Move transmission control to full forward. Hold for 15 seconds.</p> <p>Stop engine and fill reservoir to fill line.</p> <p>Start engine and idle in neutral. Hold for 10 seconds.</p>	<p>Move transmission control to full forward for 10 seconds.</p> <p>Return transmission control to neutral. Stop engine and fill reservoir to fill line.</p>	<p><b>GO TO ③ GROUP 05</b></p>
<p style="font-size: x-small;">M21,25010S,25 -19-25MAY89</p>		

<p><b>9A CHECK TRANSMISSION MOUNTING IN FRAME (Eaton Transmission)</b></p> <p>Remove fender deck-see Section 30.</p> <p>Move fuel tank to the side.</p>	 <p style="font-size: small; margin-top: 5px;">M49248 -UN-20DEC89</p>  <p style="font-size: small; margin-top: 5px;">M49249 -UN-20DEC89</p>	<p>Check nuts (A).</p> <p>Check cap screws (B).</p>
<p><b>OK: RETURN TO OPERATING TESTS.</b></p> <p><b>NOT OK: REPAIR OR REPLACE, THEN GO TO ③ GROUP 05</b></p>		
<p style="font-size: x-small;">M21,25010S,26 -19-25MAY89</p>		

<p><b>9B CHECK TRANSMISSION MOUNTING IN FRAME (Sundstrand Transmission)</b></p>	 <p style="font-size: small; margin-top: 5px;">M49250 -UN-20DEC89</p>	 <p style="font-size: small; margin-top: 5px;">M49251 -UN-20DEC89</p>	<p>Check cap screws and nuts (A).</p> <p>Check cap screws and nuts (B).</p>
<p><b>OK: RETURN TO OPERATING TESTS.</b></p> <p><b>NOT OK: REPAIR OR REPLACE, THEN GO TO ③ GROUP 05</b></p>			
<p style="font-size: x-small;">M21,25010S,27 -19-25MAY89</p>			

Hydrostatic Power Train System Diagnosis/Check Transmission Fan (Eaton Transmission)

250  
10  
10

<p><b>10A</b> CHECK BRAKE ADJUSTMENT (EATON TRANSMISSION)</p> <p>Check brake linkage.</p> <p>Check brake disk for free movement.</p>	 <p>Use feeler gauge to check clearance between pad and disk.</p> <p>Turn nut (A) to adjust.</p> <p>Specification: 0.5 mm (.02 in.)</p>	<p><b>OK:</b> RETURN TO OPERATING TESTS.</p> <p><b>NOT OK:</b> REPAIR OR REPLACE, THEN GO TO ③ GROUP 05</p> <p>M21,25010S,28 -19-25MAY89</p>
--	--	--

<p><b>10B</b> CHECK BRAKE ADJUSTMENT (SUNDSTRAND TRANSMISSION)</p>	 <p>Press manual push valve.</p> <p>Move tractor.</p> <p><i>FEEL:</i> Tractor should move easily.</p> <p>Press brake pedal.</p> <p><i>FEEL:</i> Tractor should stop.</p>	<p><b>OK:</b> RETURN TO OPERATING TESTS.</p> <p><b>NOT OK:</b> CONTINUE.</p> <p>M21,25010S,29 -19-25MAY89</p>
--	--	---

<p><b>10B</b> CHECK BRAKE ADJUSTMENT (SUNDSTRAND TRANSMISSION)</p> <p>(Continued)</p>	 <p>Lengthen link (A) by bending, if tractor did not move easily.</p> <p>Shorten link (A) by bending, if tractor did not stop.</p> <p>Retest.</p>	<p><b>OK:</b> RETURN TO OPERATING TESTS.</p> <p><b>NOT OK:</b> GO TO SECTION 50 GROUP 26. SERVICE BRAKE.</p> <p>M21,25010S,30 -19-25MAY89</p>
---	--	---

<p><b>11A</b> CHECK TRANSMISSION FAN (EATON TRANSMISSION)</p>	 <p>Check fan blades and cap screws (A). Check sheave set screws (B).</p> <p>Check for dirt on transmission.</p> <p>DO NOT use a high pressure washer to clean.</p>	<p><b>OK:</b> RETURN TO OPERATING TESTS.</p> <p><b>NOT OK:</b> REPAIR OR REPLACE, THEN RETURN TO OPERATING TESTS.</p> <p>M21,25010S,31 -19-25MAY89</p>
---	--	--

Hydrostatic Power Train System Diagnosis/Tractor moves Opposite of Control

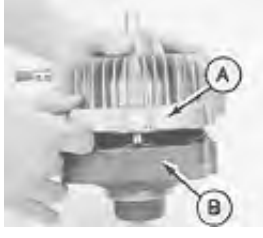
<p><b>11B</b> CHECK TRANSMISSION FAN (SUNDSTRAND TRANSMISSION)</p>	 <p>M49257 -UN-20DEC89</p>	<p>Check fan blades (A). Check sheave (B). Check nut (C). Check for dirt on transmission. DO NOT use a high pressure washer to clean.</p>	<p><b>OK:</b> RETURN TO OPERATING TESTS. <b>NOT OK:</b> REPAIR OR REPLACE THEN RETURN TO OPERATING TESTS.</p> <p>M21,25010S,32 -19-25MAY89</p>
<p><b>12</b> TRACTOR MOVES IN OPPOSITE DIRECTION OF TRANSMISSION CONTROL (EATON TRANSMISSION ONLY)</p>	 <p>M49255 -UN-20DEC89</p>	<p>This will only occur after transmission has been disassembled. Cover (A) incorrectly installed on body (B).</p>	<p>GO TO SECTION 50 GROUP 20.</p> <p>M21,25010S,33 -19-25MAY89</p>

250  
10  
11

250  
10  
12



### ABOUT THIS GROUP

Always perform the system checkout procedure in Group 06 BEFORE making any tests or adjustments in this group. The step-by-step procedures in this group provide you with the detailed diagnostic information you will need to isolate a malfunction. Basic diagnostic equipment is used.

It is assumed that you are familiar with the machine and its power train components. If you need additional information, read the theory of operation in Group 16.

Always start with the first step and follow the sequence from left to right. Read each step completely before performing the test.

Upon completing a test or adjustment, check to see whether the problem is corrected by performing the checkout procedure in Group 06.

M21,25011S,1 -19-21JAN87

#### 1 TRANSMISSION NEUTRAL ADJUSTMENT

Stop engine.

Park tractor safely

*NOTE: Fender deck is removed for photographs only. These adjustments must be made with deck in place.*



M43429 -UN-12JAN90

Put transmission in neutral.

Loosen and turn nuts (A) as required to move control lever to center of neutral slot. Tighten nut (A).



M43432 -UN-12JAN90

M21,25011S,2 -19-21OCT86



M43433 -UN-12JAN90

Loosen nuts and turn stop screw (B) to adjust control lever.



M43434 -UN-12JAN90

Turn stop screw (B) as required until control lever is 1 mm (0.04 in.) from edge of slot (C). Tighten nuts.



**AFTER ADJUSTMENT:**  
GO TO 1 GROUP 06.

M21,25011S,3 -19-21JAN87

## Gear Power Train System Diagnosis/Tractor Moves with Jerky or Erratic Motion

250  
11  
2

<p><b>2 TRANSMISSION DRIVE BELT ADJUSTMENT</b></p>	<p>Remove mower from tractor.</p> <p>Put transmission in gear to hold tractor.</p> <p>Put foot clutch in engaged or up position.</p>	 <p style="font-size: small; text-align: center;">M43435 -UN-12JAN90</p>	<p>Loosen nut (A) on adjusting idler.</p> <p>Slide adjusting idler in slot until dimension (B) of 94 mm (3.7 in.) is obtained between inner surface of flat idler and inside of frame.</p>	 <p style="font-size: small; text-align: center;">M43436 -UN-12JAN90 M21,25011S,4 -19-21OCT86</p>
--	--	---	--	--

 <p style="font-size: small; text-align: center;">M43437 -UN-12JAN90</p>	<p>Adjust belt guide to be parallel with drive belt and maintain a clearance of 5 mm (0.20 in.) between belt and guide. Tighten nut (A) on adjusting idler.</p>	 <p style="font-size: small; text-align: center;">M43438 -UN-12JAN90</p>	<p>Loosen belt guide (C) and center belt in guide loop. Tighten cap screw.</p>	<p><b>AFTER ADJUSTMENTS: GO TO 2 GROUP 06.</b></p> <p style="text-align: right; font-size: small;">M21,25011S,5 -19-21JAN87</p>
---	---	---	--	---

<p><b>3 TRANSMISSION DRIVE TEST</b></p>	<p>If tractor does not operate properly, select the appropriate symptom.</p>	<p><b>TRACTOR MOVES WITH JERKY OR ERRATIC MOTION: GO TO 4</b></p> <p><b>TRANSAXLE IS EXCESSIVELY NOISY: GO TO 6</b></p> <p><b>TRANSMISSION FREE-WHEELS OR JUMPS OUT OF GEAR: GO TO 7</b></p> <p><b>TRACTOR WILL NOT MOVE OR STALLS EASILY: GO TO 8</b></p> <p><b>TRANSMISSION HARD TO SHIFT OR GEARS CLASH WHEN SHIFTING: GO TO 10</b></p> <p><b>TRANSMISSION LOCKS IN GEAR: GO TO 10</b></p> <p style="text-align: right; font-size: small;">M21,25011S,6 -19-21JAN87</p>
---	--	--

<p><b>4 TRACTOR MOVES WITH JERKY OR ERRATIC MOTION</b></p>	 <p style="font-size: small; text-align: center;">M43439 -UN-12JAN90</p>	<p>Inspect drive belt for slippage.</p> <p>Check belt for worn or stretched areas.</p> <p>Check belt tensioning spring and idlers.</p> <p>Check all drive sheaves for dirt or debris build-up.</p>	<p><b>OK: GO TO 4A</b></p> <p><b>DRIVE BELT SLIPPING OR BELT TENSIONER DAMAGED: Replace belt, clean sheaves or repair tensioner, then... GO TO 2 TO ADJUST</b></p> <p style="font-size: small; text-align: right;">M21,25011S,7 -19-21JAN87</p>
--	---	--	---

<p><b>4A Transmission Drive Sheave Inspection</b></p>	 <p style="font-size: small; text-align: center;">M43440 -UN-12JAN90</p>	<p>Inspect drive sheaves for damage.</p> <p>Check to see that sheaves are tight.</p> <p>Inspect control linkage for wear or damage.</p>	<p><b>OK: GO TO 4B</b></p> <p><b>SHEAVES OR CONTROL LINKAGE DAMAGED: Repair or replace, then.. GO TO 2 TO ADJUST</b></p> <p style="text-align: right; font-size: small;">M21,25011S,8 -19-21OCT86</p>
---	---	---	---

*Gear Power Train System Diagnosis/Transmission Freewheels or Jumps Out of gear*

<p><b>4B Wheel and Axle Inspection</b></p>	 <p>M43441 -UN-12JAN90</p>	<p>Inspect axle-to-wheel hub key ways for wear or damage.</p>	<p><i>NOTE: It is normal to feel a slight free-wheel, then catch-up, especially when going up and down inclines. (6 in. to 8 in. is normal.) If tractor exceeds normal amount, internal transaxle damage is indicated.</i></p>	<p>AXLE-TO-WHEEL KEYWAYS OK: GO TO <b>5</b></p> <p>HUB OR AXLE KEYWAYS WORN OR DAMAGED: Replace damaged parts then...GO TO <b>3</b> GROUP 06.</p> <p>M21,25011S,9 -19-21JAN87</p>
--	---	---	--	---

250  
11  
3

<p><b>5 TRANSAXLE INSPECTION</b></p> <p>Remove and disassemble transaxle. See Group 15 in Section 50.</p>	<p>Inspect shifter fan, detent ball, and spring for damage.</p> <p>Inspect shifter collar, shaft keyways, and keys for damage.</p> <p>Inspect for broken or chipped transmission gears and differential bevel pinion gears.</p>	<p>Inspect brake shaft for damage.</p> <p>Inspect bearings for wear or damage.</p>	<p>TRANSAXLE DAMAGE: Repair or replace as necessary, then ... GO TO <b>1</b> GROUP 06.</p> <p>M21,25011S,10 -19-21JAN87</p>
---	---	--	---

<p><b>6 TRANSAXLE IS NOISY</b></p> <p>Remove and disassemble transaxle. See Group 15 in Section 50.</p>	<p>Inspect for broken or chipped transmission gears and differential bevel pinion gears.</p> <p>Inspect for worn or damaged bearings.</p> <p>Check lubricant level in transaxle. Some types of grease, when contaminated with water, will "channel" away from gears.</p>	<p>GEARS DAMAGED: Replace as necessary. Remove old lubricant and fill transaxle with 1.1 L (36 oz) of John Deere high temperature grease, then... GO TO <b>1</b> GROUP 06.</p> <p>M21,25011S,11 -19-21JAN87</p>
---	--	---

<p><b>7 TRANSMISSION FREEHWEELS OR JUMPS OUT OF GEAR</b></p>	 <p>M43442 -UN-12JAN90</p>	 <p>M43443 -UN-12JAN90</p>	<p>Inspect gear shift linkage for wear or damage.</p>	<p>LINKAGE OK: GO TO <b>7A</b></p> <p>LINKAGE DAMAGED: Repair or replace, then...GO TO <b>1</b> GROUP 06.</p> <p>M21,25011S,12 -19-21JAN87</p>
--	---	---	---	--

<p><b>7A Shifter Detent Check</b></p> <p>Remove fender deck.</p> <p>Remove transaxle drive sheave.</p>	 <p>M43444 -UN-12JAN90</p>	<p>Remove and inspect spring and detent ball.</p> <p><i>NOTE: When installing detent ball and spring, tighten set screw one full turn below flush with case cover.</i></p>	<p>SPRING OK: GO TO <b>5</b></p> <p>SPRING BROKEN OR WEAK: Replace spring, then...GO TO <b>1</b> GROUP 06.</p> <p>M21,25011S,13 -19-21JAN87</p>
--	---	--	---

*Gear Power Train System Diagnosis/Transmission Hard to Shift*

250  
11  
4

<p><b>8</b> TRACTOR WILL NOT MOVE OR STALLS EASILY</p>	 <p>M43445 -UN-12JAN90</p>	 <p>M43446 -UN-12JAN90</p>	<p>Inspect brake lock linkage.</p> <p>Inspect brake linkage. Be sure brake disk is free to turn.</p>	<p><b>OK: GO TO 5</b></p> <p><b>BRAKE STICKING:</b> Repair or replace linkage, then...GO TO <b>9</b></p> <p>M21,25011S,14 -19-21JAN87</p>
--	---	---	--	---

<p><b>9</b> BRAKE ADJUSTMENT</p> <p>Disengage park brake.</p>	 <p>M43447 -UN-12JAN90</p>	<p>Use a feeler gauge to measure clearance between pads and brake disk.</p> <p>Clearance specification: 0.5 mm (0.02 in.)</p> <p>Turn nut (A) to adjust clearance to specification.</p>	<p><b>AFTER ADJUSTMENT: GO TO 1 GROUP 06.</b></p> <p>M21,25011S,15 -19-21JAN87</p>
---	---	---	--

<p><b>10</b> TRANSMISSION HARD TO SHIFT OR GEARS CLASH WHEN SHIFTING OR TRANSMISSION LOCKS IN GEAR</p>	 <p>M43442 -UN-12JAN90</p>	 <p>M43443 -UN-12JAN90</p>	<p>Inspect gear shift linkage for wear or damage.</p>	<p><b>LINKAGE OK: GO TO 10A</b></p> <p><b>LINKAGE DAMAGED:</b> Repair or replace, then...GO TO <b>1</b> GROUP 06.</p> <p>M21,25011S,16 -19-21JAN87</p>
--	--	--	---	--

<p><b>10A</b> Traction Drive Clutch Check</p>	 <p>M43448 -UN-12JAN90</p>	<p>Inspect drive clutch linkage for wear or damage.</p>	<p><b>LINKAGE OK: GO TO 10B</b></p> <p><b>LINKAGE DAMAGED:</b> Replace, then... GO TO <b>2</b> GROUP 06.</p> <p>M21,25011S,17 -19-21JAN87</p>
---	---	---	---

<p><b>10B</b> Transaxle Case Bolt Check</p>	 <p>M43449 -UN-12JAN90</p>	<p>Inspect transaxle for loose case cap screws.</p>	<p><b>OK: GO TO 7A</b></p> <p><b>CASE CAP SCREWS LOOSE:</b> Tighten to 11 N-m (90 lb-in.), then... GO TO <b>1</b> GROUP 06.</p> <p>M21,25011S,18 -19-21JAN87</p>
---	---	---	--

## TRANSMISSION OPERATION

*NOTE: This service information is for the following machines: 165, 175 and 185 (185 up to serial no. —475000)*

The hydrostatic drive tractor is equipped with an infinite speed transmission (A).

The transmission is mounted on the differential case (B) which contains a two-pinion bevel gear differential.

A single control lever controls both speed and direction as well as braking.

A neutral-start switch (activated when brake pedal is depressed) prevents the engine from starting when control lever is in forward or reverse position.

A dump valve (C) is incorporated to allow the operator to push the tractor manually.

The cooling fan (D) cools the hydrostatic fluid in the transmission.

Power from the engine is transmitted through a drive belt to the transmission.

Power is transmitted from the transmission to the brake shaft (E), output shaft (F), and differential and axle (G). Power to the differential, transmitted through the pinion and bevel gears, turns the axle and wheels.

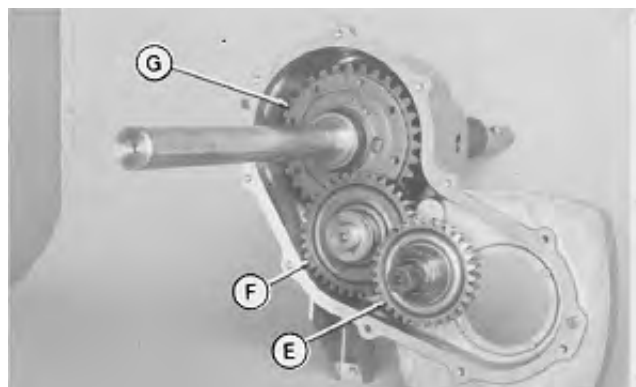
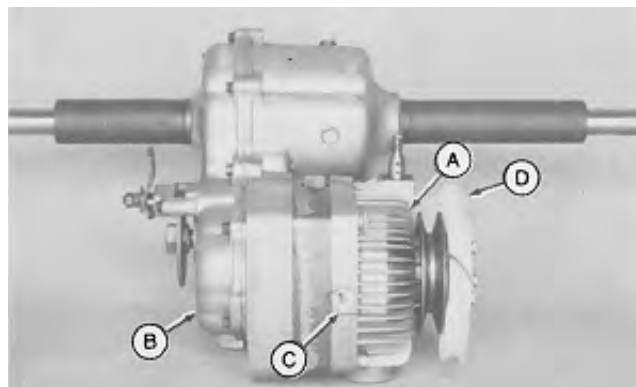

- A—Transmission
- B—Differential Case
- C—Dump Valve
- D—Cooling Fan
- E—Brake Shaft
- F—Output Shaft
- G—Differential and Axle

M21,25015,1 -19-25MAY89

250  
15  
-UN-12JAN90  
M43453  
-UN-12JAN90  
M43454

**BRAKE OPERATION**

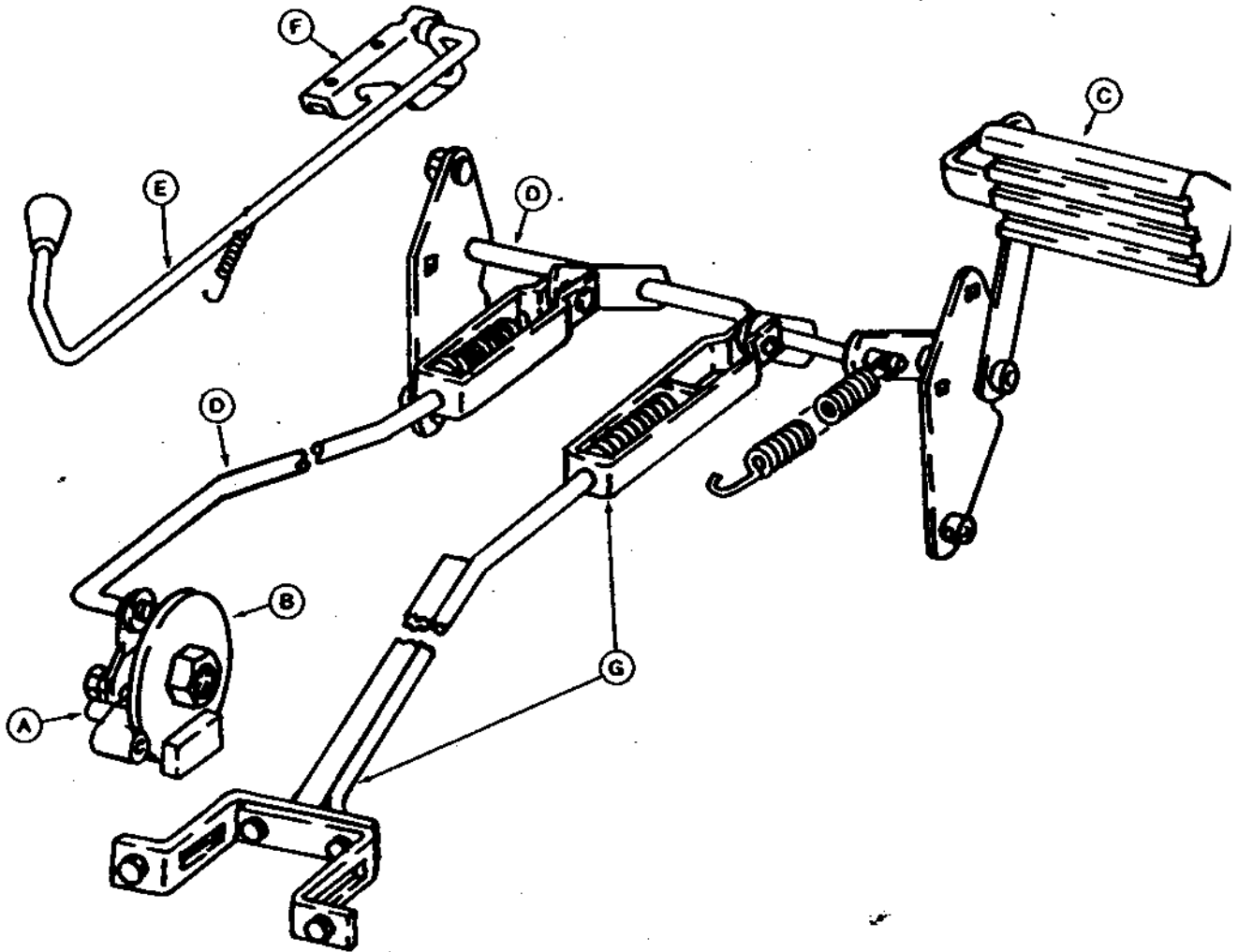

A—Brake ASsembly  
B—Brake Disk

C—Brake Pedal  
D—Brake Linkage

E—Parking Brake Lever  
F—Brake Latch

G—Transmission Neutral  
Return Linkage

*NOTE: This service information is for the following machines: 165, 175 and 185 (185 up to Serial No. —475000)*

A disk-type assembly (A) is used on the Hydrostatic Lawn Tractors. The brake assembly is attached to the left-hand side of the differential case. The brake disk (B) is connected to the brake shaft on the differential.

Depressing the brake pedal (C) pulls the brake linkage (D) forward, which compresses the brake pucks on each side of the disk. This stops movement of gears in the differential as well as tractor movement.

To set the parking brake, depress the brake pedal (C) and lower the parking brake lever (E) in the vertical slot on the deck. The latch (F) will lock the brake pedal in the depressed position. To release the parking brake, depress the brake pedal and raise parking brake lever out of long vertical slot and lower it into short vertical slot.

M43452 -UN-26APR89

**TRANSAXLE OPERATION**

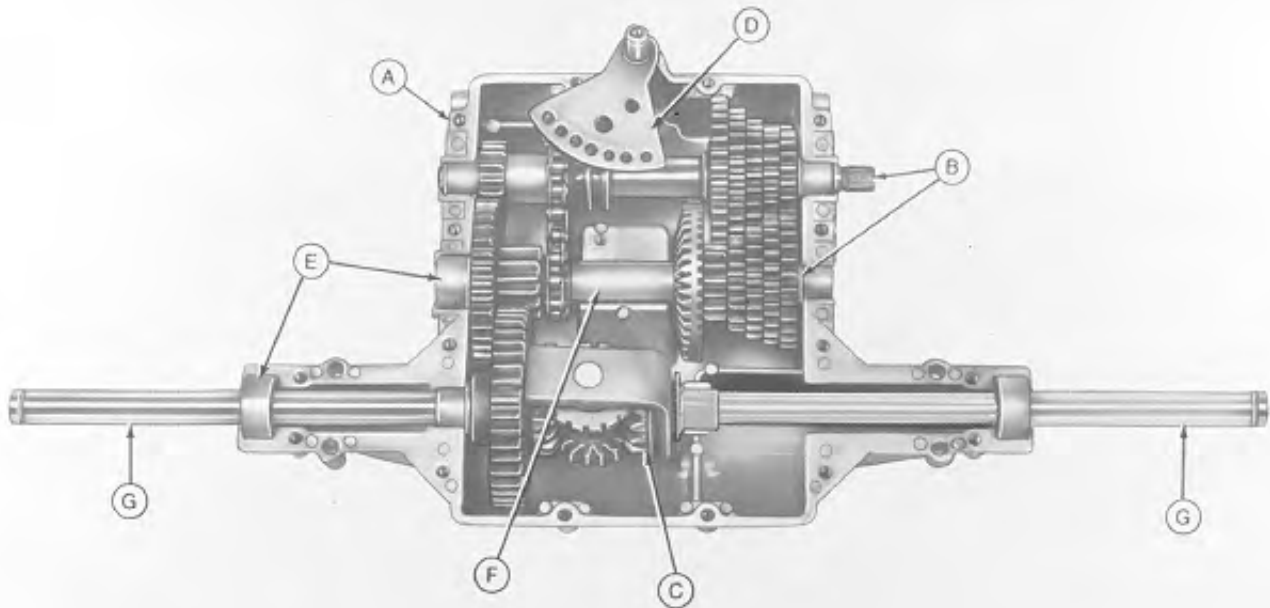

M24787

M24787 -UN-16JUN89

**A—Transaxle**  
**B—Transmission**

**C—Differential**  
**D—Gear Shift Fan**

**E—Bearings**  
**F—Countershaft**

**G—Differential Axle Shafts**

The 130, 160 and 180 Lawn Tractors are equipped with a 5-forward speed and reverse gear transaxle (A). The transaxle is a complete unit, consisting of a transmission (B) and differential (C).

Gear shifting is done with a gear shift lever connected by linkage to the gear shift fan (D). The transaxle has automotive-type alloy gears. The gears are lubricated from grease packed inside the case.

Needle or ball bearings (E) are used on the closed end of the countershaft (F), differential axle shafts (G) and input shaft.

Bushings are used on the ends of the shifter and brake shaft and on the case end of the countershaft.

A neutral-start switch (not shown), installed in top of case, detents in the shifter fan to prevent the tractor engine from starting when the transmission is in gear.

M21,25016S,1 -19-02FEB87

**BRAKE OPERATION**

250  
16  
2

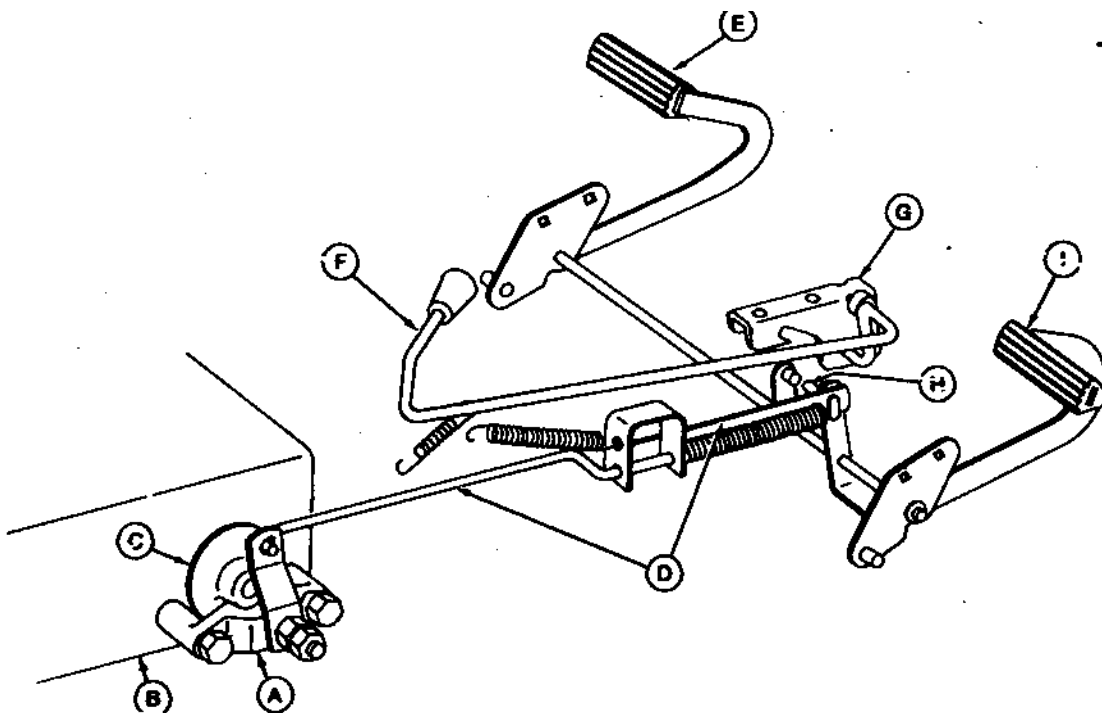

A—Brake Assembly  
B—Transaxle  
C—Disk

D—Brake Linkage  
E—Clutch Pedal

F—Parking Brake Lever  
G—Latch

H—Brake Pedal Stud  
I—Brake Pedal

A disk-type brake assembly (A) is used on the 130, 160, and 180 Lawn Tractors. The brake assembly is attached to the right-hand side of the transaxle case. The brake disk (C) is connected to the splined end of the shifter and brake shaft on the transaxle (B).

Depressing the brake pedal (I) pulls the brake linkage (D) forward, which compresses two brake pucks on each side of the disk (C). This stops movement of gears inside the transaxle as well as tractor motion.

To set the parking brake latch (G), both the brake pedal (I) and clutch pedal (E) must be fully depressed. With both pedals depressed, the parking brake lever (F) can be lowered in the long vertical slot on the deck. Lowering the parking brake lever positions the latch around the brake pedal stud (H) to lock both the clutch pedal and brake pedal in the depressed (down) position. To release the parking brake, both pedals must be fully depressed and the parking brake lever raised and lowered in the short vertical slot on the deck. This design prevents the operator from operating the tractor with the parking brake engaged.

M43450 -UN-26APR89

M21,25016S,3 -19-21JAN87



**BRAKE OPERATION**

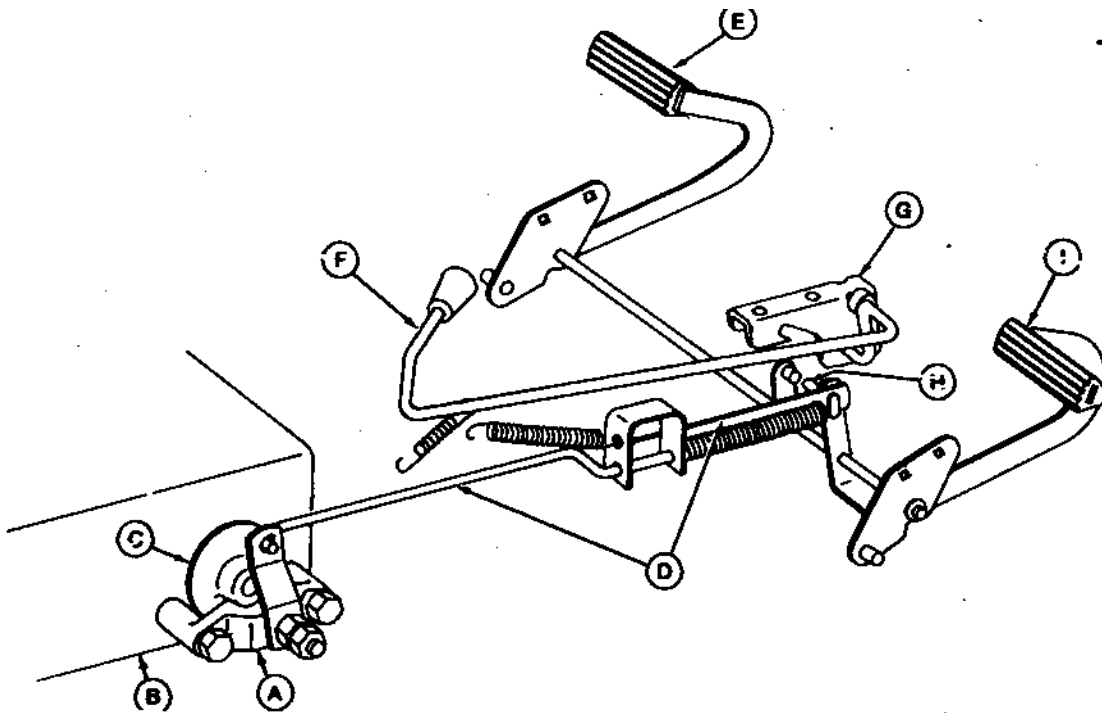

A—Brake Assembly  
B—Transaxle  
C—Disk

D—Brake Linkage  
E—Clutch Pedal

F—Parking Brake Lever  
G—Latch

H—Brake Pedal Stud  
I—Brake Pedal

A disk-type brake assembly (A) is used on the 130, 160, and 180 Lawn Tractors. The brake assembly is attached to the right-hand side of the transaxle case. The brake disk (C) is connected to the splined end of the shifter and brake shaft on the transaxle (B).

Depressing the brake pedal (I) pulls the brake linkage (D) forward, which compresses two brake pucks on each side of the disk (C). This stops movement of gears inside the transaxle as well as tractor motion.

To set the parking brake latch (G), both the brake pedal (I) and clutch pedal (E) must be fully depressed. With both pedals depressed, the parking brake lever (F) can be lowered in the long vertical slot on the deck. Lowering the parking brake lever positions the latch around the brake pedal stud (H) to lock both the clutch pedal and brake pedal in the depressed (down) position. To release the parking brake, both pedals must be fully depressed and the parking brake lever raised and lowered in the short vertical slot on the deck. This design prevents the operator from operating the tractor with the parking brake engaged.

M21,25016S,3 -19-21JAN87

M43450 -UN-26APR89

250  
16  
3

250  
16  
4

# Index

Page

## A

Avoid fires . . . . . 10-05-1

## E

Engine oil, gasoline . . . . . 10-25-2

## O

Oil, engine, gasoline . . . . . 10-25-2

INDX  
1

